



...discover it!

CMT
CATALOG
2008

Steady commitment

intense investment in advanced production technology, CMT is able to offer industrial tooling at an affordable price to an ever growing following of cabinet makers, contractors and woodworkers as well our manufacturing customers.

CMT products are manufactured for industrial applications and our tools are utilized by world leading furniture makers, kitchen manufacturers and CNC machinery manufacturers. Because of our

We are proud to be CMT Orange Tools!



CMT manufactures a wide range of industrial router bits for the production workshop, cabinet maker and fine woodworker. From diamond router bits and solid carbide router bits for the most advanced high speed CNC woodworking machines, to raised panel bits for the cabinet maker and profile bits for the woodworker, CMT utilizes the finest industrial materials, manufacturing techniques and engineering in our entire router bit product line.



There are three subcategories in the CMT saw blade family. They are: 1) Industrial blades which are intended primarily for large panel saws and other industrial saws. 2) PTFE- Coated blades & Special Application Blades are ideal for the production shop or the fine woodworker that demand the ultimate in performance and 3) "ITK" Industrial Thin Kerf saw blades which are perfect for underpowered saws and for contractors that demand industrial performance.



CMT is the leading manufacturer in the world for quality industrial boring bits. Our extensive product line includes dowel, through hole, twist drill and hinge boring bits. CMT industrial boring bits are available in solid carbide and in carbide tipped and they are available in a wide variety of sizes and sharpening for various applications. The combination of micrograin carbide, PTFE coating, high strength steel body, six axis grinding and a unique shock resistant brazing are some of the factors that make CMT the leader in industrial boring bit technology.



Italian Headquarter



US Headquarter

NEW! CMT Global Web Site!

- Full line catalogue available on line
- Instructional video on select products
- Instruction manuals available for download
- Buy Now E-Commerce
- Listing of authorized **CMT** distributors
- Company history, tech information, testimonial and more!

CMT ORANGE TOOLS

THE ART OF CUTTING

Market Area

Where are you from?

North America

Enter >>

Language

Choose favourite:

English

News

News

IWF 2008 - August 20-23, 2008

Atlanta

[More news >>](#)





Router Bits 4~61



Router Bits Sets 62~85



Jig & Accessories 86~98



Router Bits w/knives 99~105



Cutter heads & knives 106~142



Saw Blades 143~166



Solid Carbide & Chucks 167~180

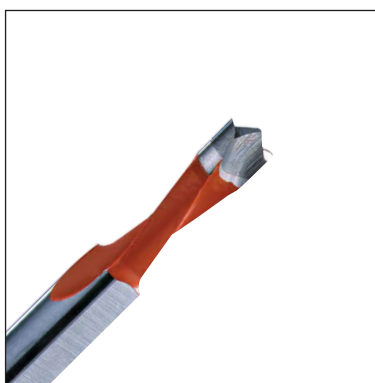

Dowell Drills 181~200

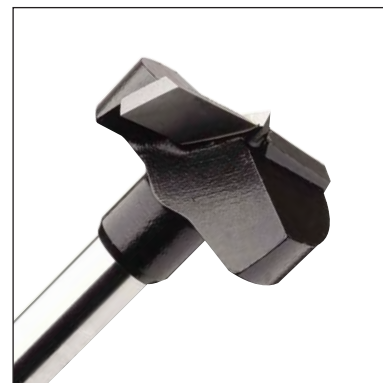

Boring Bits 201~205

CMT USA, Inc.

7609 Bentley Road Suite D
Greensboro, NC 27409

phone 336.854.0201
toll-free 888.268.2487
fax 336.854.0903
free-fax 800.268.9778

e-mail info@cmtusa.com
web site www.cmtusa.com



Router Bits



Solid Carbide Spiral Bits 6

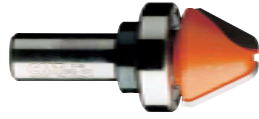

Lettering Bits & Bowl and Tray Bits 29

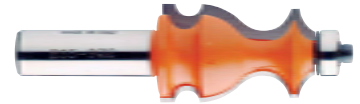

Decorative Molding Bits 44

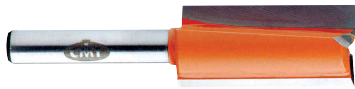

...Straight Bits 12



Rabbeting Bits 30

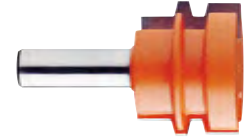

Reverse Glue Joint & Drawer Lock Bit 47

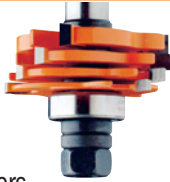

...Slot Cutters 14

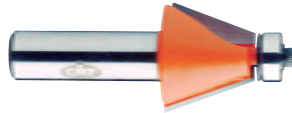

Chamfer Bits 32

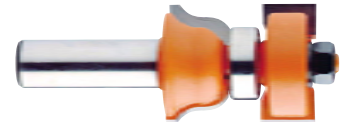

Windows Sash Bits 49



...Dovetail Bits 18

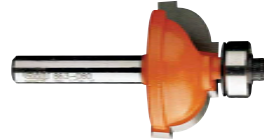

Profile Bits 34



Lock Miter Bits 52



...Flush Trim Bits 20



Cove Bits 35

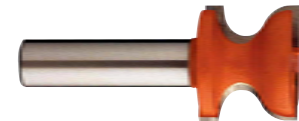

Windows Sill Bits 54



...Trimmer Bits 24



Roundover Bits 36



Raised Panel Bits 56

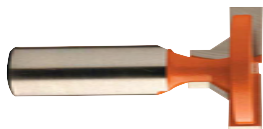

Keyhole Bit and T-Slot Bits 25



Beading & Bull Nose Bits 37

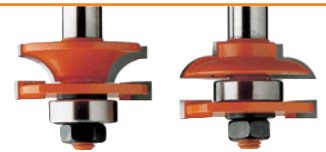

Rail & Stile Sets 59



Round Nose Bits 26



Corner Beading & Molding Bits 38



Router Bit Set with Wooden Case 62



...V-Grooving Bits 28



Ogee Bits 39



Routing System & Accessories 86

- ALWAYS** thoroughly check all tools for damage and flaws before using.
- ALWAYS** wear safety glasses and ear protection when using power tools.
- ALWAYS** thoroughly read the owners manual and manufacturer's instructions before working with tools.
- ALWAYS** be sure that at least 75% of the shank is securely inserted into the collet of the router.
- ALWAYS** use template guide collars when possible to absorb lateral forces that can deflect the bit.
- ALWAYS** watch for special safety warnings that apply to specific bit profiles. In particular, watch for the icon in this catalog that indicates that certain bits are for use in router tables only. 
- ALWAYS** use a router table and fence when possible.
- ALWAYS** use a fence when working on the router table.
- ALWAYS** reduce the router speed when working with larger diameter bits, see the chart below for suggested routing speeds. If your router does not have a built-in speed control, a number of speed controls are commercially available.
- ALWAYS** keep your fence adjusted so there is some clearance between the router bit's bearing guide and the workpiece.
- ALWAYS** take care to remove large quantities of stock (cross section > 3/8" (10mm)) in more than one cut.
- ALWAYS** keep your tools sharpened, clean and stored in a safe place to avoid breakage and accidents and to extend the life of your bits and blades.
- NEVER** use dull or defective router bits.
- NEVER** force the shank entirely into the collet (bottoming out). Leave about a 1/8" space between the end of the bit's shank and the bottom of the collet.
- NEVER** force the cut or overload the router.

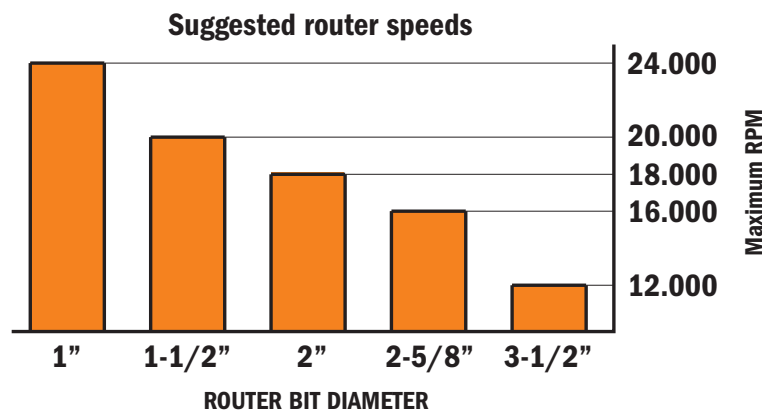

- Ø** = Diameter
- A** = Cutting angle
- B** = Bead length
- D** = Cutting diameter
- D₁** = For shank diameter
- D₂** = Overall cutting diameter
- D₃** = For bit diameter
- d** = Small cutting diameter
- H** = Cutting depth
- HL** = High-alloyed tool steel
- HS** = High speed steel
- I** = Cutting length... cutting height
- I₁** = Drilling depth
- Inches** = Inches
- L** = Overall length
- LB** = Adjusting length
- LH** = Left-hand rotation
- mm** = Millimeters
- PTFE** = Non-stick industrial coating, black and orange
- R** = Radius
- RH** = Right-hand rotation
- S** = Shank diameter
- S₁** = Shank diameter
- SP** = Alloyed tool steel
- T** = Maximum joint thickness
- Z** = Number of teeth



T.C.T.
(Tungsten carbide tipped)



S.T.C.
(Solid tungsten carbide)



Polycrystalline Diamond



Anti-kickback design



Radial relief



Not for hand held use for router tables only



Bearing diameter



Tools for manual feed



Tools for mechanical feed

5 piece Solid Carbide Spiral Bit Sets



SOLID CARBIDE

Our most popular solid carbide Spiral Bits at your fingertips in a safe, economical package! Choose upcut or downcut sets, each including 3/16", 1/4", 5/16", 3/8" and 1/2" diameters. Ideal for use on all soft and hard wood, plywood, laminates, MDF and plastic materials, with your CNC or handheld router. Remember: **upcut** bits provide fast chip ejection and deliver the finest finish on the lower surface of the workpiece. **Downcut** bits are the best choice where an ultra-smooth finish on the upper surface is the highest priority.

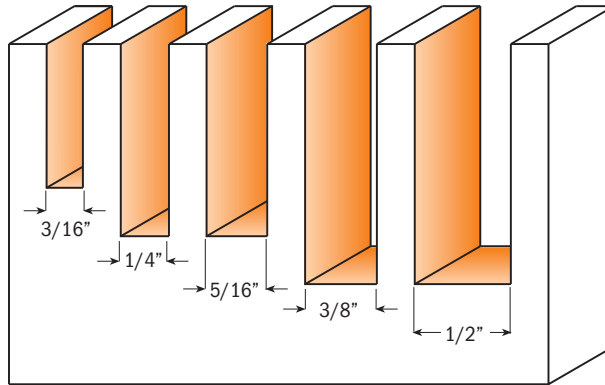

Drawings are 1:1 scale

191

192



Upcut

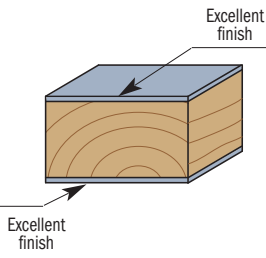

Downcut

Order No. 191.000.02 Upcut spiral bit set

Order No.	D_Cutting diameter inches	D_Cutting diameter mm	I_Cutting length inches	L_Overall length inches	S_Shank diam. inches
191.005.11	3/16	4.76	3/4	2	1/4
191.008.11	1/4	6.35	1	2-1/2	1/4
191.501.11	5/16	7.94	1	3	1/2
191.503.11	3/8	9.52	1-1/4	3	1/2
191.505.11	1/2	12.7	1-1/4	3	1/2

Order No. 192.000.02 Downcut spiral bit set

Order No.	D_Cutting diameter inches	D_Cutting diameter mm	I_Cutting length inches	L_Overall length inches	S_Shank diam. inches
192.005.11	3/16	4.76	3/4	2	1/4
192.008.11	1/4	6.35	1	2-1/2	1/4
192.501.11	5/16	7.94	1	3	1/2
192.503.11	3/8	9.52	1-1/4	3	1/2
192.505.11	1/2	12.7	1-1/4	3	1/2

Sharp technology with a new twist

A special super-micrograin carbide formulation was created to produce and hold a keen cutting edge.

The new low-angle spiral is designed specifically to shear wood cleanly and provide efficient chip ejection.

The tools run cooler and the edge lasts longer.

Increased feed rates while improving cut quality, means increased productivity with CMT.

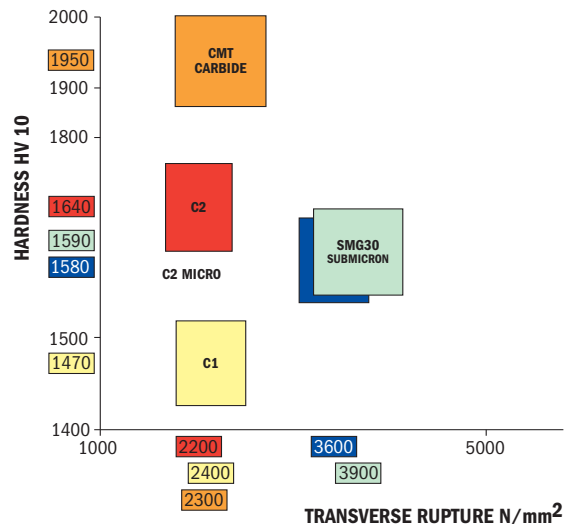

190 Compression Upcut & Downcut 2-Edge Spiral Bits

Order No. Right-hand	D_Cutting diameter inches	mm	I_Cutting length inches	L_Overall length inches	S_Shank diameter inches
190.504.11	3/8	9.52	1-1/8	3	3/8
190.505.11	1/2	12.7	1	3	1/2
190.506.11	1/2	12.7	1-1/8	3	1/2
190.507.11	1/2	12.7	1-3/8	3-1/2	1/2
190.508.11	1/2	12.7	1-5/8	4	1/2

For additional Spiral Tooling please visit pages 164-167.

191 Upcut 2-Edge Spiral Bits

Order No. Right-hand	D_Cutting diameter inches	mm	I_Cutting length inches	L_Overall length inches	S_Shank diameter inches
191.001.11	1/8	3.18	1/2	2	1/4
191.003.11	5/32	3.97	1/2	2	1/4
191.005.11	3/16	4.76	3/4	2	1/4
191.007.11	1/4	6.35	3/4	2	1/4
191.008.11	1/4	6.35	1	2-1/2	1/4
191.501.11	5/16	7.94	1	3	1/2
191.503.11	3/8	9.52	1-1/4	3	1/2
191.505.11	1/2	12.7	1-1/4	3	1/2
191.506.11	1/2	12.7	1-1/2	3-1/2	1/2
191.507.11	1/2	12.7	2	4	1/2
191.509.11	5/8	15.87	2-1/8	4-5/16	5/8
191.511.11	3/4	19.05	2-1/8	4-5/16	3/4

191.008.11-X10 10 pcs. in Masterpack

192 Downcut 2-Edge Spiral Bits

Order No.	D_Cutting diameter inches	mm	I_Cutting length inches	L_Overall length inches	S_Shank diam. inches
192.001.11	1/8	3.18	1/2	2	1/4
192.003.11	5/32	3.97	1/2	2	1/4
192.005.11	3/16	4.76	3/4	2	1/4
192.007.11	1/4	6.35	3/4	2	1/4
192.008.11	1/4	6.35	1	2-1/2	1/4
192.501.11	5/16	7.94	1	3	1/2
192.503.11	3/8	9.52	1-1/4	3	1/2
192.505.11	1/2	12.7	1-1/4	3	1/2
192.506.11	1/2	12.7	1-1/2	3-1/2	1/2
192.507.11	1/2	12.7	2	4	1/2

SOLID CARBIDE

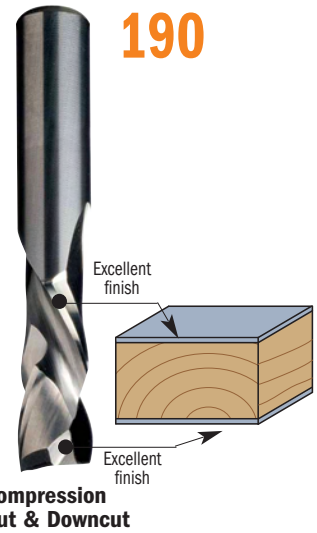

191



192

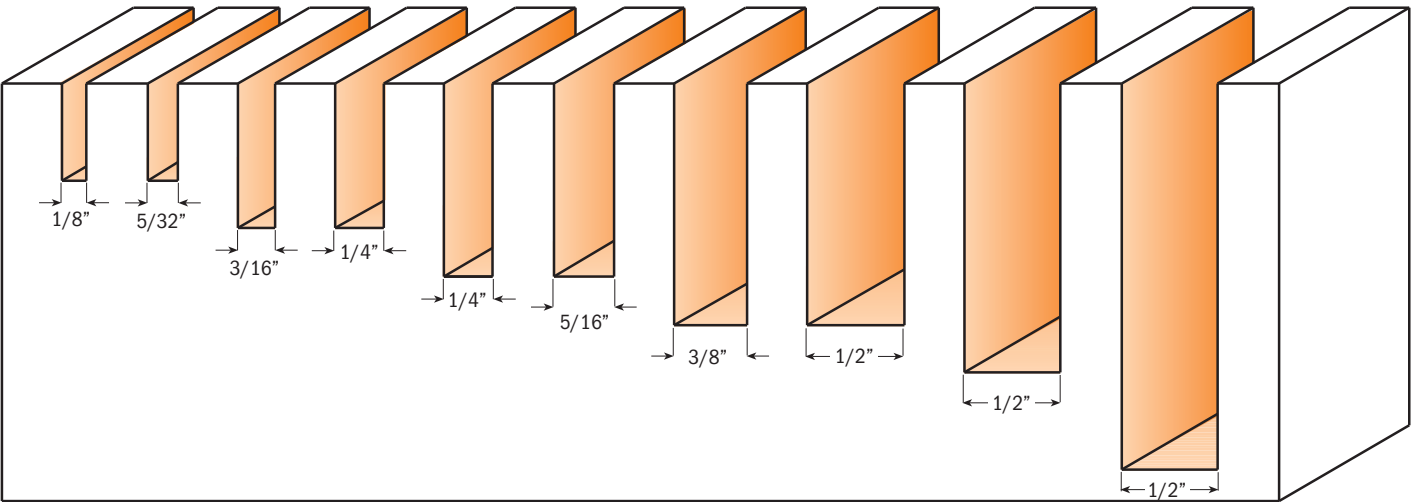
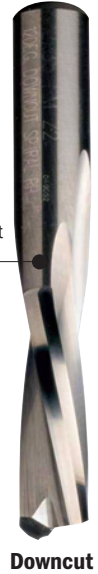

Drawings are 1:1 scale

For additional Spiral Tooling please visit page 174

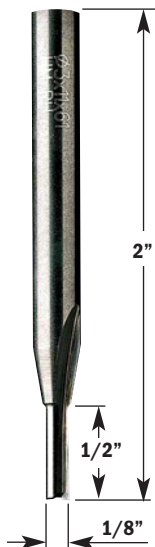

812.032

SOLID CARBIDE



Make your house more energy efficient by insulating old doors and windows. A CMT Weatherseal bit is the perfect bit to re-groove door and window frames to accommodate wind blocking inserts. Made of solid carbide for strength and endurance.

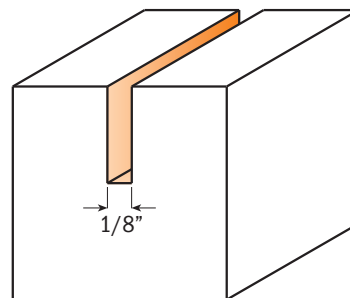
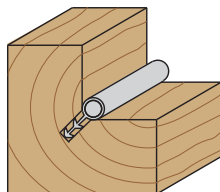

Order No.	D_Cutting diameter		I_Cutting length	L_Overall length
1/4" shank	inches	mm	inches	inches
812.032.11	1/8	3.2	1/2	2

Drawings are 1:1 scale



813.001

SOLID CARBIDE



Make your house more energy efficient by insulating old doors and windows. A CMT Weatherseal bit is the perfect bit to re-groove door and window frames to accommodate wind blocking inserts. Made of solid carbide for strength and endurance.

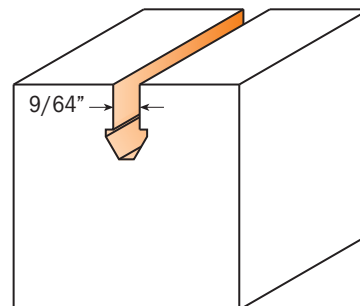
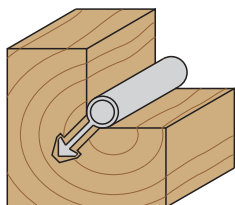

Order No.	D_Cutting diameter		I_Cutting length	L_Overall length
1/4" shank	inches	mm	inches	inches
813.001.11	9/64		5/16	2-3/4

Drawings are 1:1 scale

The next time you need a precise mortise for hinges and hardware, don't just pick up the first straight bit you can find. CMT Mortising Bits are designed specifically to rout perfect mortises with no splintered edges or rough bottoms. The negative (downward) shear angle of the cutting edges pushes the wood fibers down as they cut, eliminating the frayed edges you may have experienced with other bits. Constructed with thick micrograin carbide tips, these bits are great for both natural wood and wood composites. Our bits are available in sizes to fit most popular mortising jigs.



801

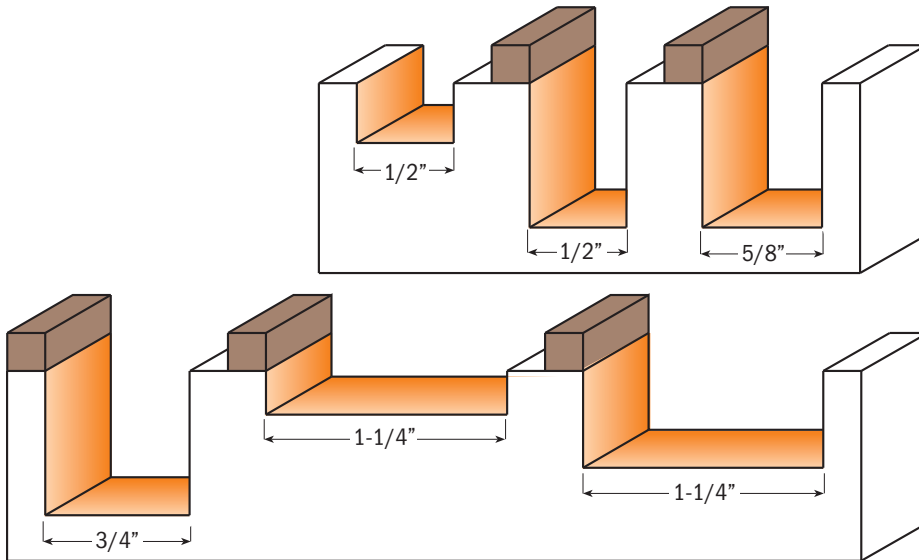
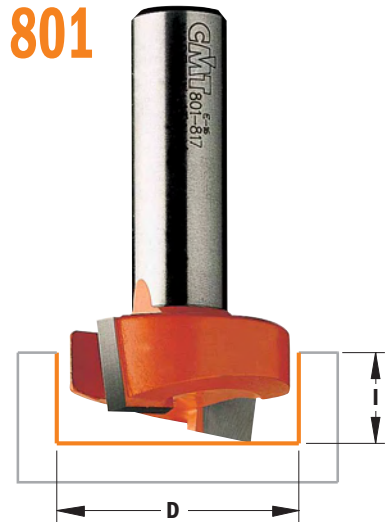

Drawings are 1:1 scale

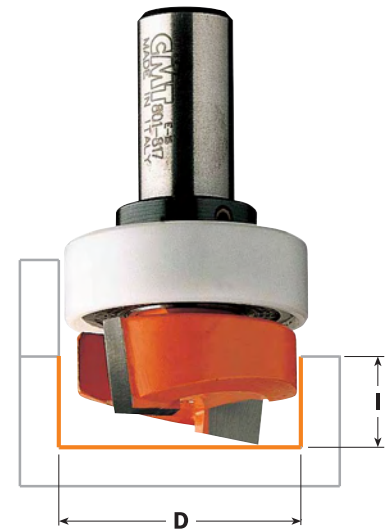

Order No. 1/4" shank	Order No. 1/2" shank	D_Cutting diameter inches	mm	I_Cutting length inches	B_Bearing diameter inches
801.128.11		1/2	12.7	5/16	
801.127.11	801.627.11	1/2	12.7	3/4	
801.158.11		5/8	15.87	3/4	
801.190.11	801.690.11	3/4	19	3/4	
	801.818.11	1-1/4	31.7	15/64	
801.317.11	801.817.11	1-1/4	31.7	1/2	
with top bearing guide					
801.127.11B		1/2	12.7	3/4	1/2
801.128.11B		1/2	12.7	5/16	1/2
801.158.11B		5/8	15.87	3/4	5/8
801.190.11B		3/4	19	3/4	3/4
	801.818.11B	1-1/4	31.7	15/64	1-1/4
	801.817.11B	1-1/4	31.7	1/2	1-1/4
spare parts:					
791.010.00	1/2" bearing				
791.009.00	5/8" bearing				
791.004.00	3/4" bearing				
791.015.00	1-1/4" bearing				
541.001.00	Stop collar for 1/4" shank				
541.002.00	Stop collar for 1/2" shank				
991.056.00	1.5mm hex key for stop collars				

852



CMT Dado & Planer bits are perfect for polishing dadoes or smoothing rough stock. Made of super strong steel with thick carbide tips, these bits work well for any task. Use them to strip paint and varnish. Available with ball bearing guide for easy pattern work.

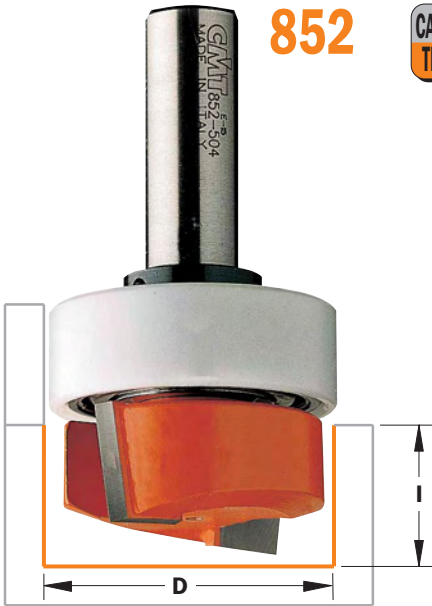

Order No. 1/4" shank	Order No. 1/2" shank	D_Cutting diameter		I_Cutting length	B_Bearing diameter
		inches	mm	inches	inches
852.001.11	852.501.11	3/4	19	3/8	
	852.502.11	1	25.4	3/8	
	852.503.11	1-1/4	31.7	5/8	
	852.504.11	1-1/2	38.1	5/8	
with top bearing					
852.001.11B	852.501.11B	3/4	19	3/8	3/4
	852.503.11B	1-1/4	31.7	5/8	1-1/4
	852.504.11B	1-1/2	38.1	5/8	1-1/2
spare parts:					
791.004.00	3/4" bearing (1/4" shank)	541.001.00	Stop collar for 1/4" shank		
791.011.00	3/4" bearing (1/2" shank)	541.002.00	Stop collar for 1/2" shank		
791.015.00	1-1/4" bearing	991.056.00	1.5mm hex key for stop collars		
791.020.00	1-1/2" bearing				

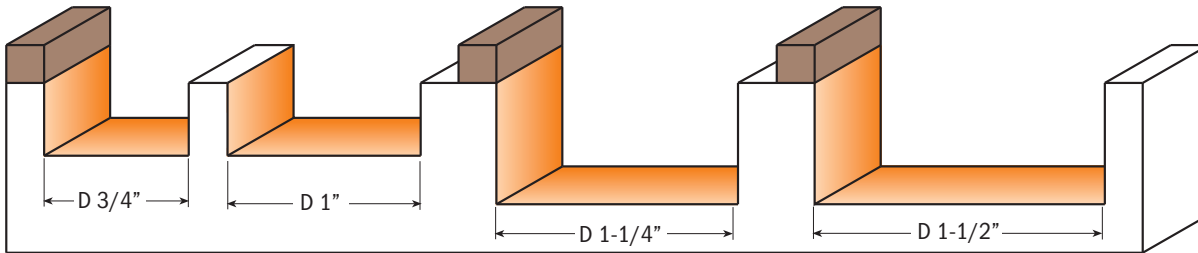

Drawings are 1:1 scale

Plywood Groove Sets

811



Fed up with gaps and sloppy joints when you rout grooves and dadoes for plywood joints? Our Plywood Groove Bits match the true thickness of plywood, producing tight, accurate joints. Use our 23/32" bit for 3/4" plywood, 31/64" bit for 1/2" plywood and our 15/64" for 1/4" plywood.



Example shown in 1/2" thick plywood

This joint is made with the CMT 31/64" straight bit in 1/2" plywood. Notice the precise fit - no gaps.

This joint is made with a regular 1/2" straight bit in 1/2" plywood. Notice the extra space and ill fitting joint.

Set contains	Order No.	D_Cutting diameter inches	I_Cutting length inches
Order No. 811.001.11 3 piece Plywood Groove Set			1/4" Shank
Straight bit	811.060.11	15/64	5/8
Straight bit	811.123.11	31/64	1
Straight bit	811.182.11	23/32	1
Order No. 811.501.11 3 piece Plywood Groove Set			1/2" Shank
Straight bit	811.560.11	15/64	3/4
Straight bit	811.623.11	31/64	1
Straight bit	811.682.11	23/32	1

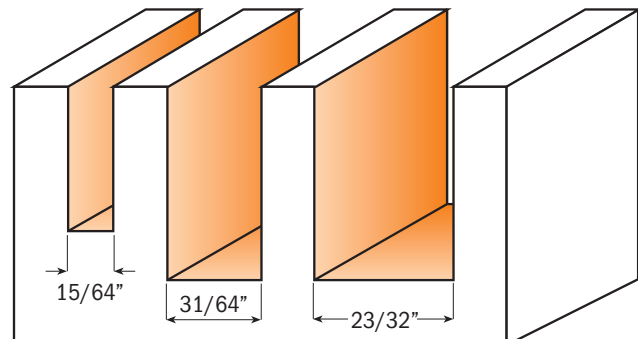

Drawings are 1:1 scale

Complicated, curved shapes can present a real challenge to the most experienced woodworker, especially when the job requires multiple copies of the same shape. But CMT's Top Bearing Pattern bits can make almost any of these tasks easier and faster. Just mill an accurate pattern of the desired shape, then rout as many identical parts as you need.



811B
812B

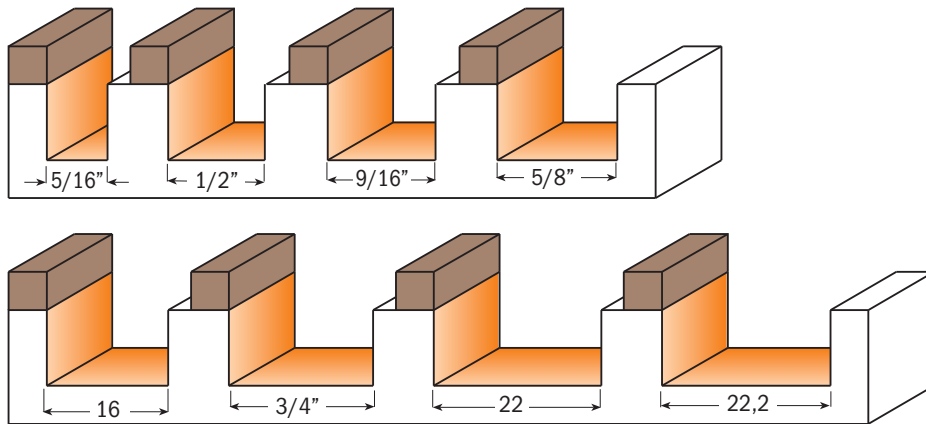
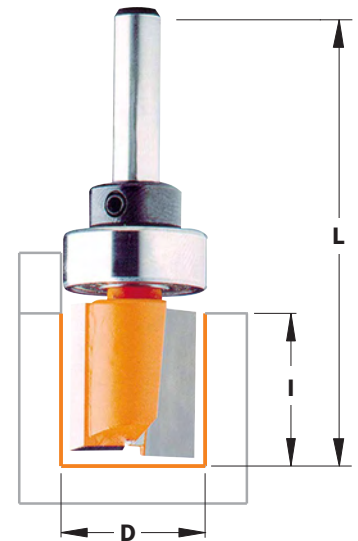

Drawings are 1:1 scale

Order No. 1/4" shank	Order No. 1/2" shank	D_Cutting diameter inches	mm	I_Cutting length inches	L_Overall length inches	B_Bearing diameter inches
811.081.11B		5/16	8	1	2-13/16	1/2
811.127.11B		1/2	12.7	3/4	2-1/4	1/2
811.142.11B		9/16	14.2	9/16	2-1/4	5/8
811.159.11B		5/8	15.87	1/2	2-9/32	5/8
811.158.11B		5/8	15.87	3/4	2-5/8	5/8
811.191.11B		3/4	19	3/4	2-1/4	3/4
	811.690.11B	3/4	19	1	2-1/2	3/4
	811.222.11B	7/8	22.2	1	2-5/8	7/8
812.127.11B		1/2	12.7	1-1/4	2-3/4	1/2
812.158.11B		5/8	15.87	1-1/4	2-3/4	5/8
	812.690.11B	3/4	19	1-1/2	3-1/4	3/4
	812.691.11B	3/4	19	2	3-1/4	3/4
spare parts:		791.010.00	1/2" bearing	799.001.00	3/8" - 1/2" bushing	
		791.009.00	5/8" bearing	541.001.00	Stop collar for 1/4" shank	
		791.004.00	3/4" bearing (1/4" shank)	541.002.00	Stop collar for 1/2" shank	
		791.011.00	3/4" bearing (1/2" shank)	991.056.00	1.5mm hex key for stop collars	
		791.021.00	7/8" bearing			

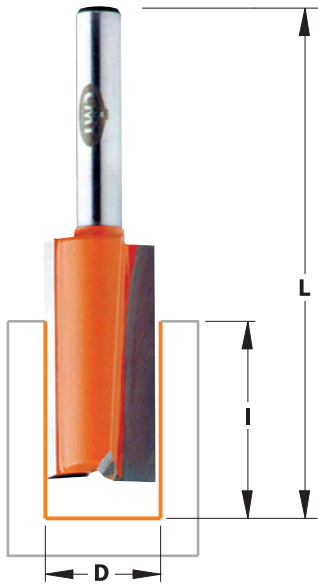

811

Order No. 1/4" shank	Order No. 1/2" shank	D_Cutting diameter inches	D_Cutting diameter mm	L_Cutting length inches	L_Overall length inches	
• 811.020.11			2	5/32	1-1/2	
• 811.030.11			3	5/16	1-3/4	
• 811.032.11		1/8	3.2	3/8	1-3/4	
• 811.040.11		5/32	4	3/8	1-3/4	Bit for biscuits
• 811.047.11		3/16	4.75	1/2	2	
• 811.050.11			5	15/32	2	
• 811.060.11		15/64	6	5/8	2	Ply-groove bit
	• 811.560.11	15/64	6	3/4	2-3/8	Ply-groove bit
• 811.064.11		1/4	6.35	3/4	2	
• 811.065.11		1/4	6.35	3/4	2-1/4	For Incra Jig
	• 811.564.11	1/4	6.35	3/4	2-3/8	For Incra Jig
• 811.070.11			7	23/32	1-7/8	
• 811.080.11		5/16	8	3/4	2	
• 811.081.11		5/16	8	1	2-13/16	For Leigh Jig
811.095.11		3/8	9.5	3/4	2	
811.096.11		3/8	9.5	1	2-1/2	For Incra Jig
	new 811.581.11	5-16	8	1	2-3/4	For Incra Jig
	811.595.11	3/8	9.5	1	2-5/8	For Incra Jig
811.100.11			10	3/4	1-7/8	
	811.600.11		10	1	2-1/2	
811.120.11			12	3/4	2	
	811.620.11		12	1	2-1/2	
811.123.11		31/64	12.3	1	2-1/4	Ply-groove bit
	811.623.11	31/64	12.3	1	2-1/2	Ply-groove bit
811.127.11		1/2	12.7	3/4	2-1/4	
	811.627.11	1/2	12.7	1	2-5/8	
	811.628.11	1/2	12.7	1-1/4	3-1/4	For Leigh Jig
811.140.11			14	3/4	2	
811.142.11		9/16	14.2	9/16	2-1/4	
811.150.11			15	3/4	2-1/4	
811.158.11		5/8	15.87	3/4	2-5/8	
	811.660.11	5/8	15.87	1	2-1/2	
811.160.11			16	3/4	2-1/4	
	811.661.11		16	1	2-1/2	
811.180.11			18	3/4	2	
811.182.11		23/32	18.2	1	2-1/4	Ply-groove bit
	811.682.11	23/32	18.2	1	2-1/2	Ply-groove bit
811.191.11		3/4	19	3/4	2-1/4	
	811.690.11	3/4	19	1	2-1/2	
811.200.11			20	3/4	2	
811.220.11			22	3/4	2-1/4	
811.254.11		1	25.4	3/4	2	
	811.754.11	1	25.4	1-1/4	3	
	811.785.11	1-1/8	28.57	1-1/4	3	
811.065.11-X10		1/4	6.35	3/4	2-1/4	10 pcs. in Masterpack

• Solid Carbide

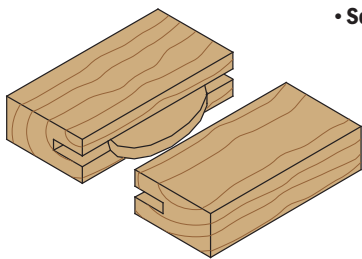

Biscuit joint using bit #811.040.11

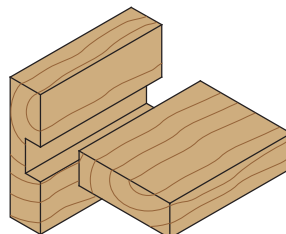

Dado

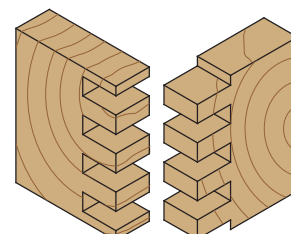

Box joint

CMT's Straight Bits offer the full package of features that define our top-quality tools: razor-sharp edges, special high-strength steel and the finest micrograin carbide.

Our straight bits can withstand even the heaviest work load and still give you a smooth, precise cut every time. They also provide exceptional chip ejection to allow cleaner and more constant cutting. The surfaces of all CMT bits are protected with our unique orange P.T.F.E. Industrial Coating to help keep the bit from collecting resin, pitch and other residue.

CMT's selection of 62 Straight Bits allows production at an industrial scale on a variety of plywood, composites and natural woods.

Safety Precautions: never use damaged or worn bits. Always work at the proper feed rate without forcing the bit. Pay particular attention when making the initial cut with a small diameter bit. For best results when working with small diameter bits, make the cut in more than one pass.



812

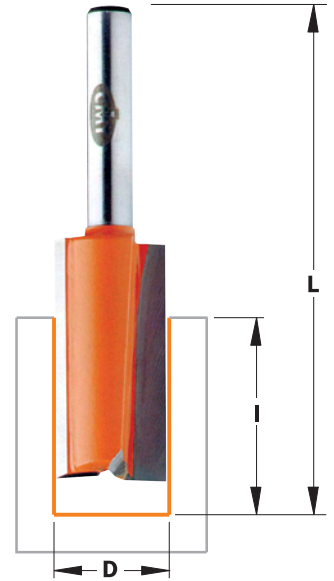

Order No. 1/4" shank	Order No. 1/2" shank	D_Cutting diameter		I_Cutting length	L_Overall length	
		inches	mm	inches	inches	
• 812.032.11		1/8	3.2	1/2	2	
• 812.060.11		15/64	6	1	2-3/8	
• 812.064.11		1/4	6.35	1	2-3/8	
• 812.080.11		5/16	8	1-1/4	2-3/8	
812.095.11		3/8	9.5	1-1/4	2-1/2	
	812.595.11	3/8	9.5	1-1/4	2-7/8	
812.100.11			10	1-1/4	2-3/8	
	812.600.11		10	1-1/4	2-3/4	
	812.611.11	7/16	11.1	1-1/4	3-1/4	
812.120.11			12	1-1/4	2-3/8	
	812.620.11		12	1-1/4	2-3/4	
	812.621.11		12	1-1/2	3-3/4	
812.127.11		1/2	12.7	1-1/4	2-3/4	
	812.627.11	1/2	12.7	1-1/2	3-3/4	
	812.628.11	1/2	12.7	2	4-1/4	
	812.629.11	1/2	12.7	2-1/2	4-3/8	
812.140.11			14	1-1/4	2-3/8	
812.150.11			15	1-1/4	2-5/8	
812.158.11		5/8	15.87	1-1/4	2-3/4	
812.160.11			16	1-1/4	2-5/8	
	812.660.11		16	1-1/4	2-3/4	
	812.690.11	3/4	19	1-1/2	3-1/4	
	812.691.11	3/4	19	2	3-5/8	
	812.627.11-X10	1/2	12.7	1-1/2	3-3/4	10 pcs. in Masterpack
	812.628.11-X10	1/2	12.7	2	4-1/4	10 pcs. in Masterpack
	812.629.11-X10	1/2	12.7	2-1/2	4-3/8	10 pcs. in Masterpack
	812.690.11-X10	3/4	19	1-1/2	3-1/4	10 pcs. in Masterpack

For Leigh Jig

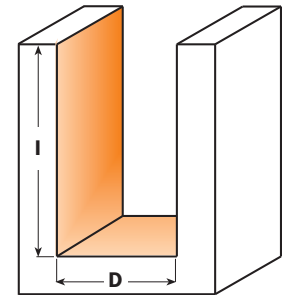

• Solid Carbide

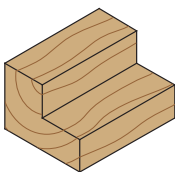

Rabbet

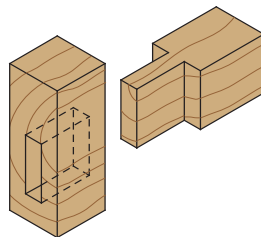

Mortise and Tenon

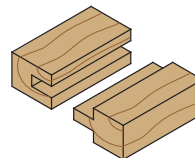

Tongue and groove joint

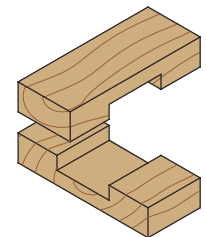

Lap and cross-lap

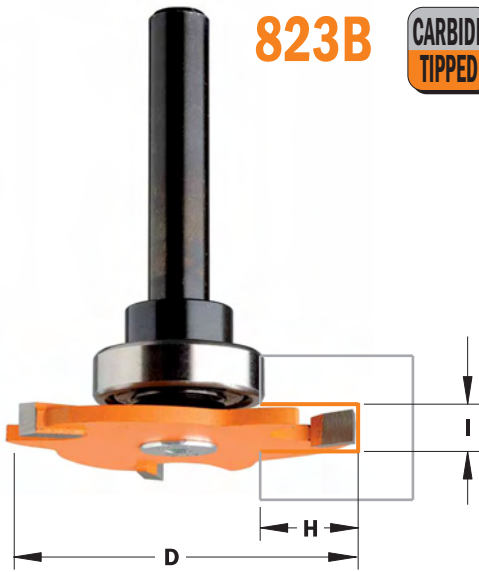

823B



This versatile slot cutter provides a variety of cutting options. Using a countersunk bolt the cutter can be mounted at the end of the arbor to allow undercutting; great for making lock rabbet joints as well as standard slots, biscuit joints, and many more. Each bit has 3 carbide tipped cutting wings, PTFE coating and an anti-kickback design feature. The 22mm bearing provides a 1/2" depth of cut and available in a 1/8", 5/32", and 1/4" cutting lengths. The slot cutter, arbor and bearing are all available separately.

Order No. 1/2" shank	I_Cutting length inches mm	D_Cutting diameter inches	H_Cutting depth inches
823.332.11B	1/8 3.2	1-7/8	1/2
823.340.11B	5/32 4	1-7/8	1/2
823.364.11B	1/4 6.35	1-7/8	1/2

Slot Cutters and Arbors



824.121



These three wing carbide tipped Slot Cutters feature anti-kickback three wing blade design and CMT's trademark orange P.T.F.E. Industrial Coating. All cutters feature an 8mm bore that fits CMT's arbors (items 824).



824.122

Order No. 1/2" shank	Description
824.121.00	Slot cutter arbor without bearing (short series)
824.121.10	Slot cutter arbor with bearing (short series)
824.122.00	Slot cutter arbor without bearing (long series)
824.122.10	Slot cutter arbor with bearing (long series)

spare parts:	Price	Description
791.005.00	022mm bearing	
541.515.00	0.1mm spacer	
541.516.00	0.3mm spacer	
541.517.00	0.5mm spacer	
541.518.00	1mm spacer	
990.055.00	Screw TSPEI M5x12mm	

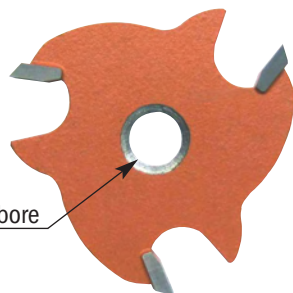

823

45° bore

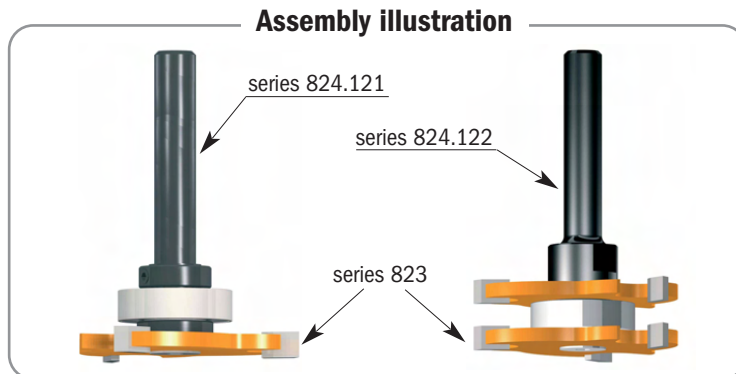

Order No.	I_Cutting length inches mm	D_Cutting diameter inches	F_Bore diameter mm
823.332.11	1/8 3.2	1-7/8	8
823.340.11	5/32 4	1-7/8	8
823.364.11	1/4 6.35	1-7/8	8

CMT's Slot Cutters are great for splines, biscuits, T-molding & more. For biscuit joining use the 5/32" cutter. Available as a cutter only, or with your choice of 1/4" or 1/2" diameter arbor with a 7/8" diameter bearing for cutting depth up to 1/2".

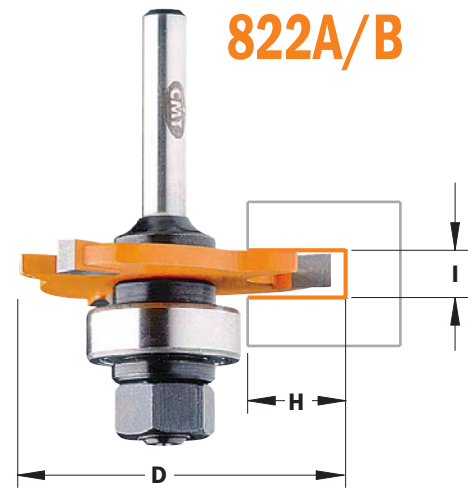
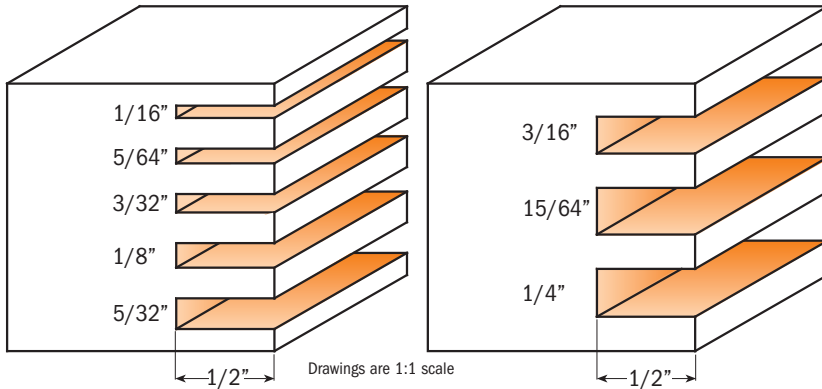

Order No. 1/4" shank	Order No. 1/2" shank	I_Cutting length inches	I_Cutting length mm	D_Cutting diameter inches	H_Cutting depth inches
822.316.11A	822.316.11B	1/16	1.6	1-7/8	1/2
822.320.11A	822.320.11B	5/64	2	1-7/8	1/2
822.324.11A	822.324.11B	3/32	2.4	1-7/8	1/2
822.332.11A	822.332.11B	1/8	3.2	1-7/8	1/2
822.340.11A	822.340.11B	5/32	4	1-7/8	1/2
822.348.11A	822.348.11B	3/16	4.8	1-7/8	1/2
822.360.11A	822.360.11B	15/64	6	1-7/8	1/2
822.364.11A	822.364.11B	1/4	6.4	1-7/8	1/2

Slot Cutters and Arbors

The best Slot Cutter won't give you a clean cut without a top quality, perfectly concentric arbor. That's why CMT arbors are carefully machined from special high-strength steel and precision ground in all critical areas. Available as arbor only or with 7/8" (22mm) bearing.

These three wing carbide tipped Slot Cutters feature anti-kick-back design and CMT's trademark orange P.T.F.E. Industrial Coating. All cutters feature an 8mm bore that fits CMT's 1/4" and 1/2" arbors.

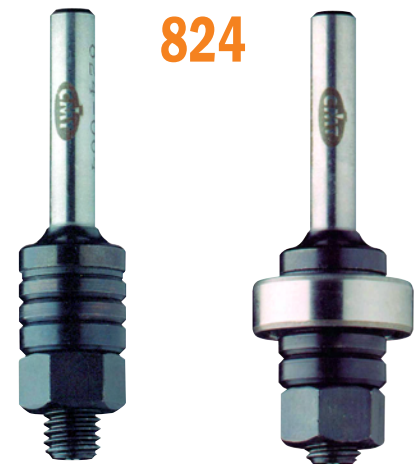

Order No. 1/4" shank	Order No. 1/2" shank	Description
824.064.00	824.127.00	Slot cutter arbor without bearing
824.064.10	824.127.10	Slot cutter arbor with bearing
spare parts:	791.005.00	22mm bearing
	541.501.00	4mm spacer
	541.500.00	3mm spacer
	541.518.00	1mm spacer
	990.020.00	Nut for arbor, M8 thread

Order No.	I_Cutting length inches	I_Cutting length mm	D_Cutting diameter inches	F_Bore diameter mm
822.316.11	1/16	1.6	1-7/8	8
822.320.11	5/64	2	1-7/8	8
822.324.11	3/32	2.4	1-7/8	8
822.332.11	1/8	3.2	1-7/8	8
822.340.11	5/32	4	1-7/8	8
822.348.11	3/16	4.8	1-7/8	8
822.360.11	15/64	6	1-7/8	8
822.364.11	1/4	6.4	1-7/8	8



823.001

Create slots, grooves and rabbets in all materials using the adjustable CMT slot cutter set. See chart below for all application and correct cutter combinations. Ideal for biscuit joints and milling perfect tongue and groove joints.

The set includes 4 different bearings which allow different cutting depth: 5/16" - 3/8" - 1/2" - 9/16".

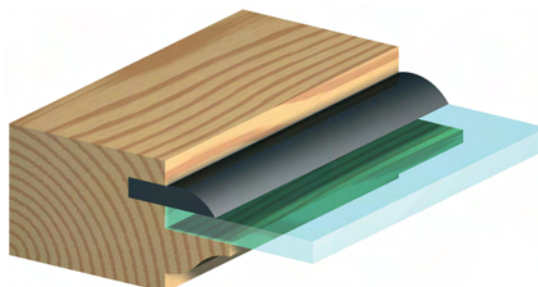

Safety tips: Never use the slot cutter set without shims between the cutters. The distance between the cutters can vary from 1mm to 1.7mm.

A shim must also be positioned between the ball bearing and the cutters.

Assembly illustration

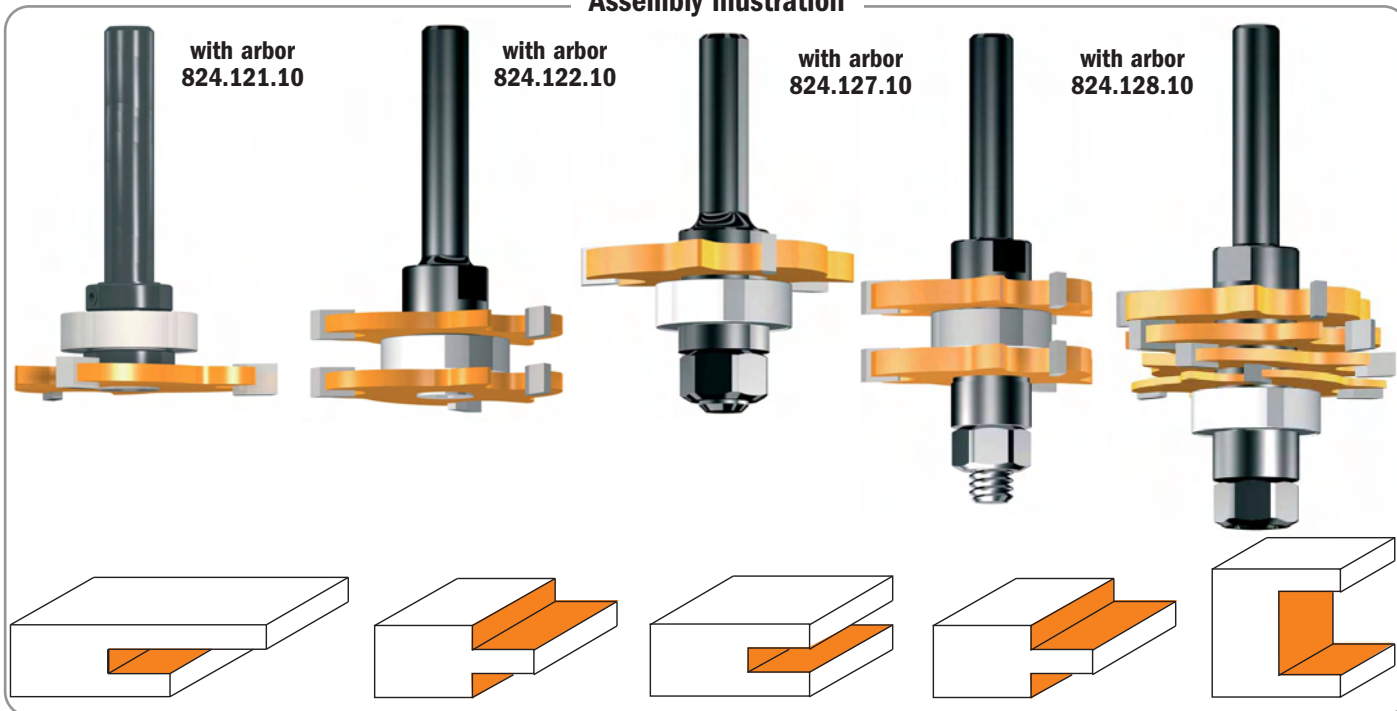

Order No. 823.001.11 Slot Cutter Set

Set contains	Pieces	Order No.	S_Shank diameter inches	I_Cutting length inches	I_Cutting length mm	D_Cutting diameter inches	D_Cutting diameter mm	F_Bore diameter mm
Slot cutter	1	822.316.11		1/16	1.58	1-7/8	47.6	8
Slot cutter with 45° bore	1	823.332.11		1/8	3.17	1-7/8	47.6	8
Slot cutter with 45° bore	1	823.340.11		5/32	3.96	1-7/8	47.6	8
Slot cutter	1	822.348.11		3/16	4.76	1-7/8	47.6	8
Slot cutter with 45° bore	3	823.364.11		1/4	6.35	1-7/8	47.6	8
Slot cutter arbor with bearing Ø22mm	1	824.121.10	1/2					
Slot cutter arbor with bearing Ø22mm	1	824.122.10	1/2					
Slot cutter arbor with bearing Ø22mm	1	824.127.10	1/2					
Slot cutter arbor with bearing Ø22mm long series	1	824.128.10	1/2					
Bearing	1	791.033.00				1-1/4	31.7	
Bearing	1	791.030.00				1-1/8	28.57	
Bearing	1	791.034.00				3/4	19.05	
Hex key 3mm	1	991.067.00						

CMT's Three Wing Slot Cutter Set routs slots, grooves and rabbets from 1/8" to 23/32" deep.

Ideal for biscuit joints and milling perfect tongue and groove joints.

The set includes:

- 4 carbide tipped cutters 1/8", 5/32", 3/16", 1/4"
- 1 arbor 1/2"
- 1 ball bearing (22mm) for 1/2" cut.
- 17 shims: (8 x 0.1mm, 4 x 0.5mm, 3 x 1mm, 2 x 4mm).

Safety Precautions:

Never use without shims between the cutters and between the cutter & bearing.

Shop Tips:

The bearings kit **791.711.00** allows to make 1/4" and 3/8" cutting depth.



800.506

Cutter combination	Cutting height	
	inches	inches
A	0.126	
B	0.157	
C	0.189	
D	0.252	
A + B	0.252	to 0.279
A + C	0.283	to 0.311
A + D	0.346	to 0.374
B + C	0.315	to 0.342
B + D	0.378	to 0.405
C + D	0.409	to 0.437
A + B + C	0.409	to 0.464
A + B + D	0.468	to 0.523
A + C + D	0.500	to 0.555
B + C + D	0.531	to 0.586
A + B + C + D	0.626	to 0.708

Use shims to adjust cut width: MIN. 0.039" - MAX 0.066"

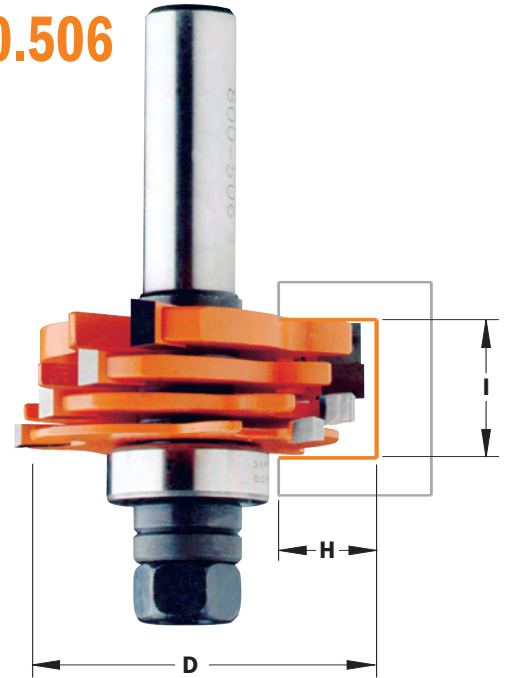

Order No.	I_Cutting length	D_Cutting diam.	H_Cutting depth
1/2" shank	inches	mm	inches
800.506.11	1/8 to 23/32	3.2-18	1-7/8
spare parts:	824.128.00	1/2" arbor with shims	
	791.711.00	Kit of two bearing (1-1/8" & 1-3/8") for slot cutter	
	791.005.00	Ø22mm bearing	
	541.515.00	0.1mm spacer	
	541.517.00	0.5mm spacer	
	541.518.00	1mm spacer	
	990.020.00	Nut for arbor, M8 thread	

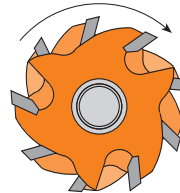

Note: the carbide edges of the cutters should never touch; arrange the shims as illustrated below. Use only the thicknesses provided in the set. Be sure all cutters are assembled in the proper rotational direction as shown below. Looking down the arbor the cutters will turn clockwise.

Tongue and Groove Set

Make tongue and groove joints without the complicated process of taking apart and reassembling bits. The CMT Tongue and Groove Set gives you one bit to rout the slot and a separate bit to mill the tongue. Or use your imagination and put them to work individually on other projects. Makes tongue and groove cuts in wood up to 3/4" thick.



800.626

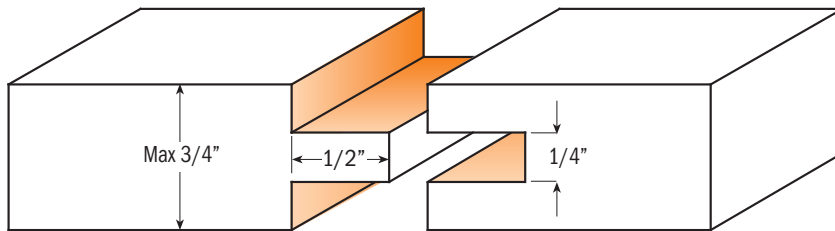

Drawings are 1:1 scale

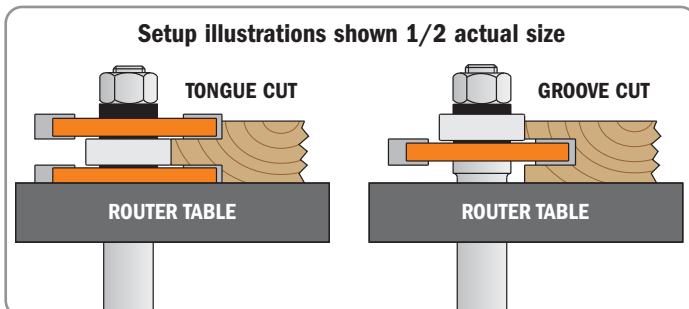

Order No.	I_Cutting length	D_Cutting diameter	H_Cutting depth
1/2" shank	inches	mm	inches
800.626.11	3/4	19	1-7/8
spare parts:	824.131.00	1/2" arbor	
	822.364.11	1/4" Slot cutter	
	791.005.00	Ø22mm bearing	
	541.515.00	0.1mm spacer	
	541.516.00	0.3mm spacer	
	541.517.00	0.5mm spacer	
	541.518.00	1mm spacer	
	990.020.00	Nut for arbor, M8 thread	

818
818B



Our selection of solid carbide or carbide tipped dovetail bits includes sizes to suit almost any of the dozens of jigs on the market. Check the overall length of the bit to be sure you get the size you need - we have bits specifically to fit on jigs and routers that require a longer shank length.

Here are a few of the beautiful dovetail joints you can produce using CMT bits

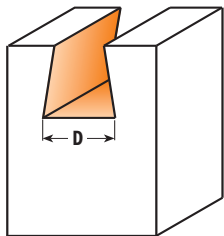
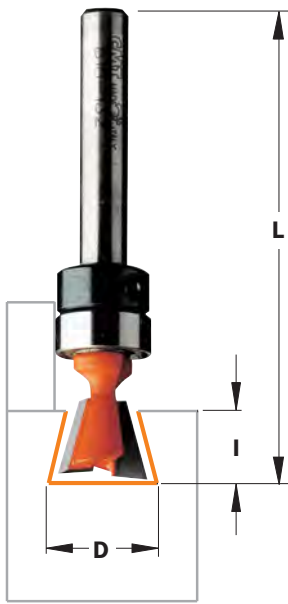
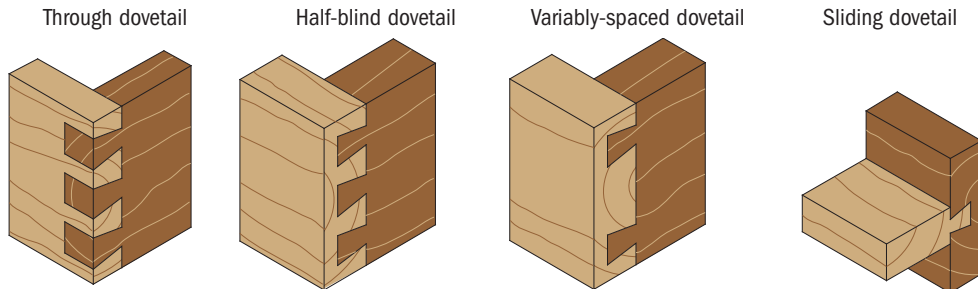

Drawings are 1:1 scale

Order No. 1/4" shank	Order No. 1/2" shank	D_Cutting diameter inches	mm	I_Cutting length inches	A_Cutting angle	L_Overall length inches	
• 818.065.11		1/4	6.35	1/4	8°	2	For Leigh Jig
• 818.064.11	• 818.564.11	1/4	6.35	5/16	7.5°	2-1/2	For Incra Jig
• 818.081.11		5/16	8	3/8	8°	2-1/8	For Leigh Jig
• 818.080.11		5/16	8	3/8	9°	2-1/16	For Incra Jig
	• 818.580.11	5/16	8	3/8	9°	2-1/2	For Incra Jig
• 818.096.11		3/8	9.5	3/8	9°	2-1/16	For Incra Jig
	• 818.596.11	3/8	9.5	3/8	9°	2-1/2	For Incra Jig
• 818.098.11		3/8	9.5	3/8	14°	2-3/8	
• 818.097.11		3/8	9.5	1/2	8°	2-3/8	For Leigh Jig
818.111.11		7/16	11.1	5/8	8°	2-3/8	For Leigh Jig
818.132.11		1/2	12.7	13/32	18°	2-3/8	For Leigh Jig
818.128.11		1/2	12.7	1/2	14°	2-1/16	For Incra Jig
	818.628.11	1/2	12.7	1/2	14°	2-1/2	For Incra Jig
818.130.11		1/2	12.7	1/2	14°	2-7/16	For Leigh Jig
818.133.11		1/2	12.7	5/8	10°	2-3/8	For Leigh Jig
818.129.11		1/2	12.7	13/16	8°	2-3/4	For Leigh Jig
	818.635.11	17/32	13.5	3/4	7°	2-27/64	For Porter Cable
818.142.11		9/16	14.2	3/8	14°	2	
818.158.11		5/8	15.87	7/8	7°	2-3/8	For Incra Jig
	818.658.11	5/8	15.87	7/8	7°	2-5/8	For Incra Jig
	818.674.11	11/16	17.4	1	8°	3-1/16	For Leigh Jig
	818.691.11	3/4	19	3/4	14°	3-1/16	
818.190.11		3/4	19	7/8	7°	2-3/8	For Incra Jig
	818.690.11	3/4	19	7/8	7°	2-5/8	For Incra Jig
818.191.11		3/4	19	7/8	14°	2-3/8	
	818.706.11	13/16	20.6	1-1/4	8°	3-5/16	For Leigh Jig
with top bearing guide							
818.087.11B		11/32	8.73	13/32	7°	1-1/4	
new 818.098.11B		3/8	9.5	3/8	14°	2-3/8	For CMT-Enlock1
818.113.11B		7/16	11.1	3/4	7°	2-5/8	
new 818.128.11B		1/2	12.7	1/2	14°	2-1/16	For CMT-Enlock1
818.142.11B		9/16	14.2	3/8	14°	2	
818.159.11B		5/8	15.87	1	7°	2-11/16	
spare parts:							
	791.010.00	1/2" bearing					
	791.009.00	5/8" bearing					
	791.021.00	7/8" bearing					
	541.001.00	Stop collar for 1/4" shank					
	991.056.00	1.5mm hex key for stop collars					

• Solid Carbide

The new CMT dovetail bits are designed to fit Hoffmann® key models W1, W2 and W3. The bits are manufactured in solid micrograin carbide to guarantee long lasting performance to avoid router bit failure during the woodworking process.

SOLID CARBIDE



818

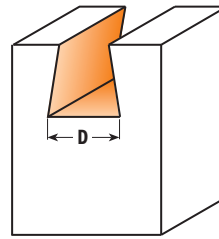
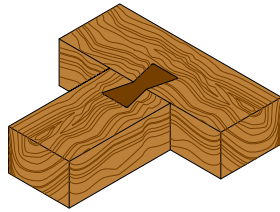

Drawings are 1:1 scale

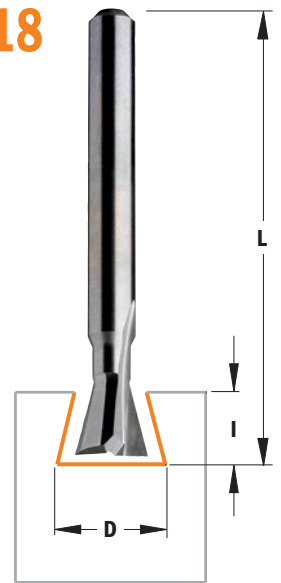

Order No. 1/4" shank	D_Cutting diameter		I_Cutting length	A_Cutting angle	L_Overall length	
	inches	mm	inches		inches	
818.053.11	13/64	5.3	5/32	17°	1-11/16	For Hoffmann W1
818.079.11	5/16	7.9	15/64	18°	1-11/16	For Hoffmann W2
818.093.11	3/8	9.3	9/32	19°	1-11/16	For Hoffmann W3

The new CMT router bit set designed exclusively for the Prazi Chestmate™ dovetail jig. CMT is the recommended partner for the Chestmate™ jig and will provide the best finish for through dovetails.

CARBIDE TIPPED

SOLID CARBIDE

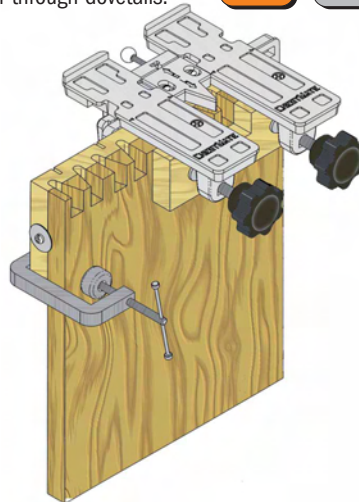

Order No. **818.501.11** 3 piece Chestmate™ Router Bits Set **1/2" Shank**

Set contains	Order No. 1/2" shank	D_Cutting diameter		I_Cutting length	A_Cutting angle	L_Overall length
		inches	mm	inches		inches
Straight bit	• 811.581.11	5/16	8	2		2-3/4
Dovetail bit	818.628.11	1/2	12.7	1/2	14°	2-1/2
Dovetail bit	818.691.11	3/4	19	3/4	14°	3-1/16

• Solid Carbide

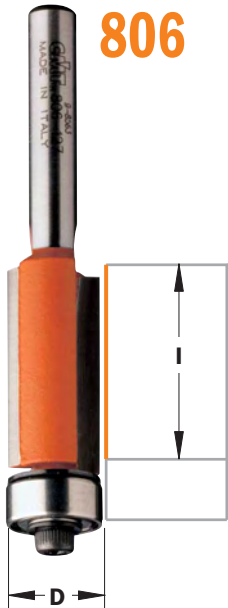

806



Tough, versatile, fast-cutting CMT Flush Trim bits are ideal for a wide variety of trimming jobs. We offer a wide range of sizes that are sure to satisfy any woodworing need. Use these carbide tipped bits for precision work on laminates or for quick template work with excellent finish results.

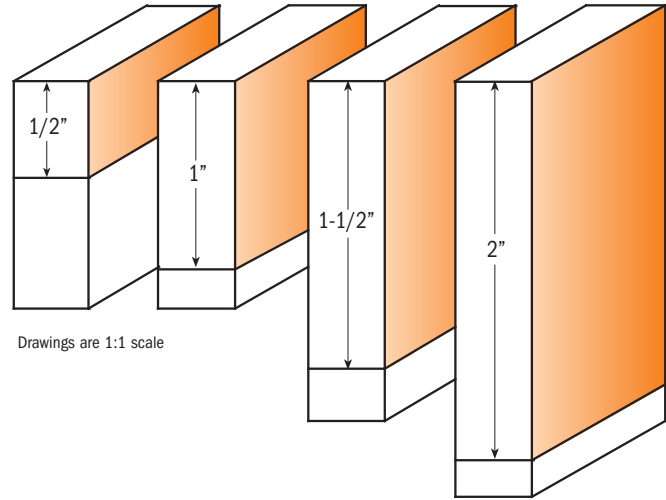

Drawings are 1:1 scale

Order No. 1/4" shank	Order No. 1/2" shank	I_Cutting length inches	mm	D_Cutting diameter inches	B_Bearing diameter inches	
• 806.064.11		1	25.4	1/4	1/4	
806.096.11		1/2	12.7	3/8	3/8	
806.128.11	806.628.11	1/2	12.7	1/2	1/2	
806.095.11		1	25.4	3/8	3/8	
806.127.11	806.627.11	1	25.4	1/2	1/2	
	806.629.11	1-1/2	38.1	1/2	1/2	
	806.630.11	2	50.8	1/2	1/2	
806.095.11-X10		1	25.4	3/8	1/4	10 pcs. in Masterpack
806.096.11-X10		1/2	12.7	3/8	3/8	10 pcs. in Masterpack
806.127.11-X10	806.627.11-X10	1	25.4	1/2	1/2	10 pcs. in Masterpack
806.128.11-X10		1/2	12.7	1/2	1/2	10 pcs. in Masterpack
	806.629.11-X10	1-1/2	38.1	1/2	1/2	10 pcs. in Masterpack
spare parts:	990.422.00	3/8" shield		791.035.00	1/4" bearing	
	990.423.00	1/2" shield		541.350.00	1/8" seeger	
	791.002.00	3/8" bearing		990.058.00	1/8" screw	
	791.003.00	1/2" bearing		991.057.00	3/32" hex key	

• Solid Carbide

Flush Trim Bit Set



806.001



Indispensible in any shop! The new Three Bit Flush Trim Set gives you the option to trim laminates or do template work in one convenient set.

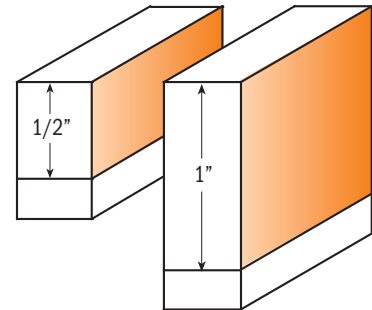

Drawings are 1:1 scale

Order No. **806.001.11** 3 piece Flush Trim Set 1/4" Shank

Set contains	Order No. 1/4" shank	D_Cutting diameter inches	I_Cutting length inches
Flush Trim bit	806.095.11	3/8	1/2
Flush Trim bit	806.096.11	3/8	1
Flush Trim bit	806.191.11	3/4	1

CMT's Super-duty Flush Trim bits are designed for your toughest and most critical trim jobs. The negative shear angle cutting edge and 3/4" cutting diameter set CMT Flush Trim bits apart from standard bits. The downward shear cutting action virtually eliminates any chipping or splintering on the top surface of the workpiece, even when the job requires fast cuts in delicate materials.



806

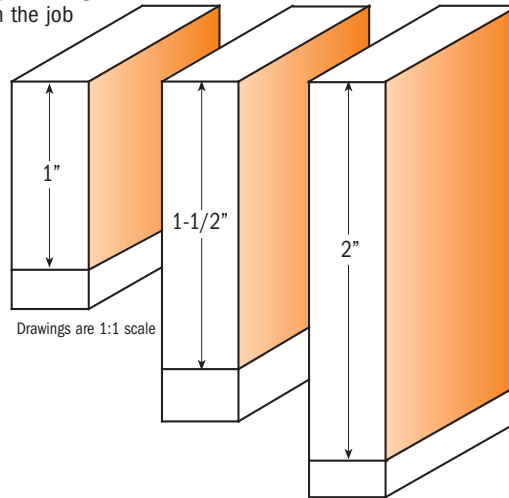
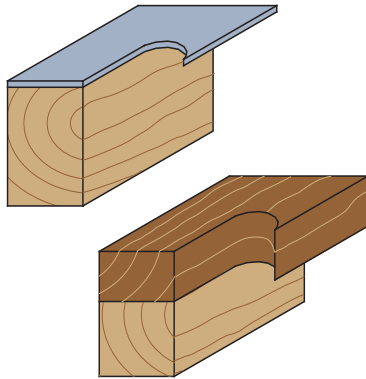

Order No. 1/4" shank	Order No. 1/2" shank	I_Cutting length inches	mm	D_Cutting diameter inches	B_Bearing diameter inches
806.191.11	806.691.11	1	25.4	3/4	3/4
	806.692.11	1-1/2	38.1	3/4	3/4
	806.690.11	2	50.8	3/4	3/4
spare parts:					
791.004.00	3/4" bearing				
541.550.00	1/8" shield				
990.058.00	1/8" screw				
991.057.00	3/3" hex key				

new

Double-Bearing Spiral Flush Trim Bits

The new line of CMT solid carbide spiral flush trim bits are manufactured with a special super-micrograin formulation that has increased hardness with a higher transverse rupture point.



190B
191B
192B

Combined with the low helix cutting angle, the new CMT solid carbide spiral flush trim bits with bearings allow the cabinet maker to shear wood and wood products cleanly while providing more efficient chip ejection than standard flush trim bits. In a production setting, these new bits will run cooler and the edge will stay sharper longer which translates into increased productivity for your shop.

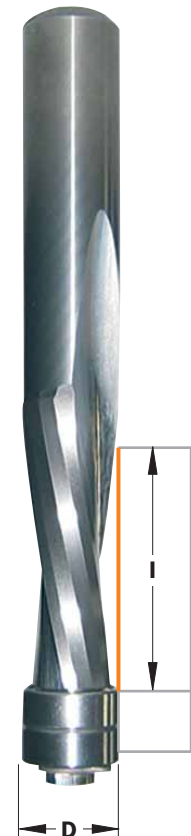
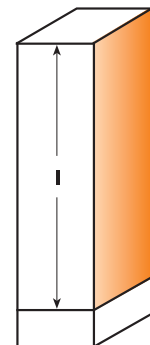

Order No. 1/4" shank	Order No. 1/2" shank	D_Cutting diameter inches	mm	I_Cutting length inches	L_Overall length inches
Z2+2 Upcut & Downcut					
	190.508.11B	1/2	12.7	1-5/8	4
Z2 Upcut					
191.008.11B		1/4	6.35	1	3
	191.505.11B	1/2	12.7	1-1/4	3
	191.507.11B	1/2	12.7	2	4
Z2 Downcut					
	192.505.11B	1/2	12.7	1-1/4	3
	192.507.11B	1/2	12.7	2	4
spare parts:					
791.010.00	1/2" bearing				
541.301.00	1/4" seeger				

new

3in1 Flush trim bit for laminates

new

CMT ORANGE TOOLS™

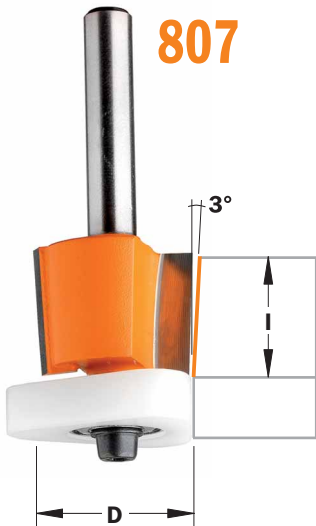

807

CARBIDE TIPPED



3in1 New flush trim bits with Delrin® Triangular bearings is your best partner for laminate trimming. It solves 3 of the most common problems that occur in flush trimming in cabinet shops:

- 1) The freezing of the bearings from glue; the Delrin® with it's anti-stick properties greatly reduces the likelihood of bearing failure.
- 2) The extended guide surface of the new Delrin® bearing will perfectly match the work surface without scratching like the steel bearing and guarantees the maximum stability.
- 3) The shear angle cutting edge reduces the need for filing.

3in1 bit is ideal on plastic laminates as well as aluminum laminate!

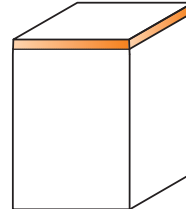
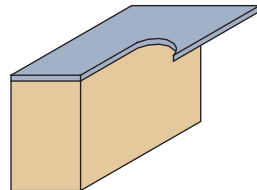

Drawings are 1:1 scale

Patent pending

- Extended guide surface
- Non freezing
- Non scratch surface



Order No. 1/4" shank	Order No. 1/2" shank	I_Cutting length inches	mm	D_Cutting diameter inches	B_Spare Bearing
807.128.11		1/2	12.7	1/2	791.042.00
807.190.11	807.690.11	5/8	15.87	3/4	791.043.00
spare parts:		791.042.00	1/2" triangular bearing	990.058.00	1/8" screw
		791.043.00	3/4" triangular bearing	991.057.00	3/32" hex key

Perfect trimming with the conical edges!

Thanks to the innovating conical edges of this bit you will always get perfect cuts even after resharpening.
The most popular problem you have with the standard flush trim bits is the undersize diameter after resharpening which leaves the mark on the material; now with the new CMT construction you could resharpen up to six times without any problem.
Just remember to adjust your bit up or down. See illustration.

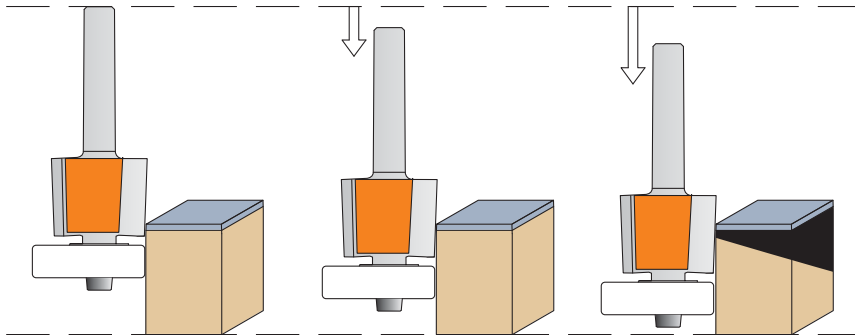

Diamond Flush Trim Bits for laminates

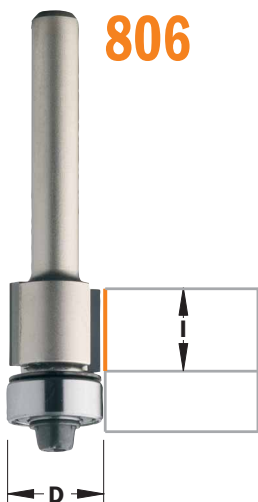

806

DP



These new super duty DP (polycrystalline diamond) bits represent the ultimate in the extensive line of CMT flush trim bits. Investing in CMT DP flush trim will save the cabinet manufacturer time and money as they last at least 50X longer than conventional carbide tipped flush trim bits.

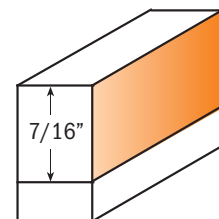
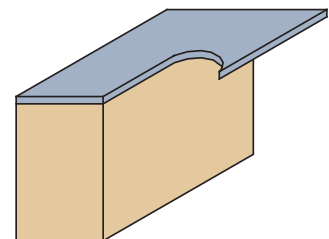

Drawings are 1:1 scale

Order No. 1/4" shank	I_Cutting length inches	mm	D_Cutting diameter inches	B_Bearing diameter inches
806.128.61	7/16	11	1/2	1/2
spare parts:				
990.423.00	1/2" shield			
791.003.00	1/2" bearing			
990.058.00	1/8" screw			
991.057.00	3/32" hex key			

The new CMT router bits are indispensable to create your tenons and jointing with the Domino® Joining System by Festool®. Buy it now to obtain the best finish for your Domino™ Joiner!



380



Order No.	D_Cutting diameter mm	I_Cutting length mm	L_Overall length mm	S_Shank diameter mm
380.050.11	5	20	49	M6x0,75
380.060.11	6	28	49	M6x0,75
380.080.11	8	28	49	M6x0,75
380.100.11	10	28	49	M6x0,75

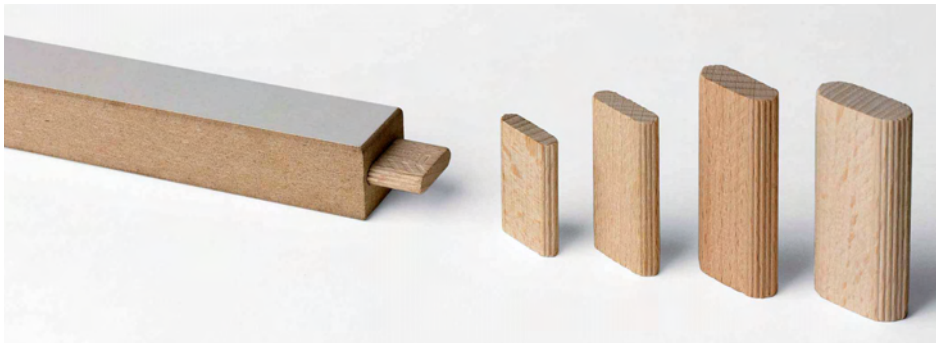

Flush & V-Groove Bits

This bit should be in every cabinetmaker's collection. The CMT Flush and V-Groove bit allows you to trim cabinet face frames (up to 1" thick) perfectly flush with the sides. As it trims, the bit adds a decorative v-groove where the face meets the side to help hide the seam.



853

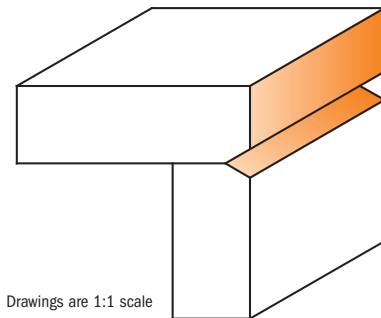
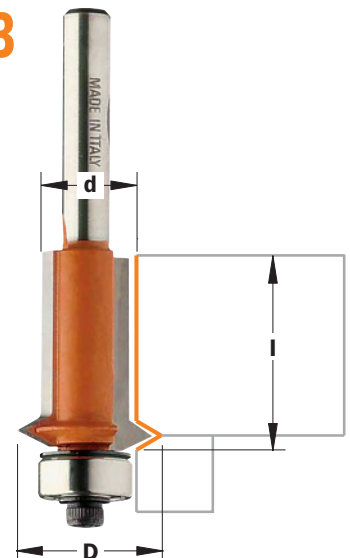

Drawings are 1:1 scale

Order No. 1/4" shank	Order No. 1/2" shank	d_Cutting diameter inches	D_Cutting diameter mm	D_Cutting diameter inches	I_Cutting length inches
853.001.11	853.501.11	1/2	12.7	3/4	1
spare parts:		990.423.00	1/2" shield	990.058.00	Screw for bearing, 1/8Wx3/8"
		791.003.00	1/2" bearing	991.057.00	3/32" hex key for 1/8W screws

821



Now you can cut, trim and bevel almost any laminate or hard or soft wood without having to change bits. Available in three popular sizes, each with carbide cutting edges for clean cuts on bevel or straight edges. NOTE: must be used with edge or bearing guide or fence.

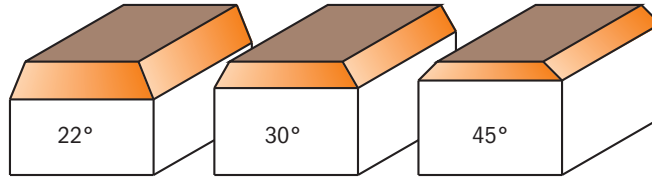
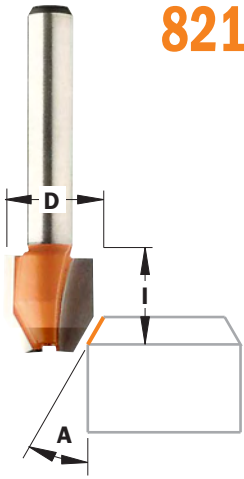

Drawings are 1:1 scale

Order No. 1/4" shank	A_Cutting angle	D_Cutting diameter inches	mm	I_Cutting length inches
821.022.11	0° - 22°	15/32	11.90	1/2
821.030.11	0° - 30°	15/32	11.90	1/2
821.045.11	0° - 45°	15/32	11.90	1/2

Trimmer Bits

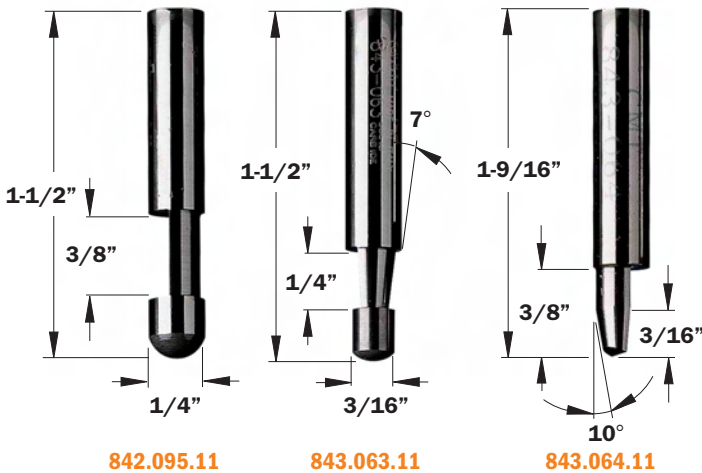

842 843



An economical version of our Combination Trimmer Bits, these Solid Carbide Trimmer Bits give you quick, clean, straight or bevel edges. With its self pilot end and radial relief cutting edge you can make flush or 7° bevel cuts. For more versatility, choose the combination flush 0°-10° bit. Popular for their long life, they are a great choice for laminate work.

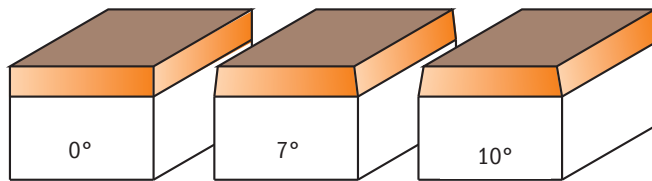

Drawings are 1:1 scale

Order No. 1/4" shank	A_Cutting angle	D_Cutting diameter inches	mm	I_Cutting length inches
842.095.11	0°	1/4	6.35	3/8
843.063.11	7°	1/4	6.35	1/4
843.064.11	0° - 10°	1/4	6.35	3/8
842.095.11-X50	50 pcs. in Masterpack			
843.063.11-X50	50 pcs. in Masterpack			

This family of t-shaped bits performs tasks you just can't tackle with any other tool. With a Keyhole Bit you can make key slots that keep picture frames, plaques or any wall hanging perfectly straight and attached to the wall, without unsightly fasteners. Or use our new T-Slot Bit to create jigs and fixtures, knock-down displays, or many other projects with a hook or the head of a bolt locked into the slot.

Drawings are 1:1 scale

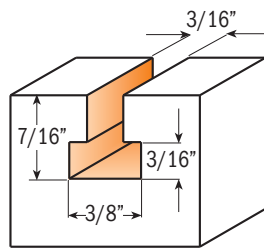

850.001.11 - 850.501.11

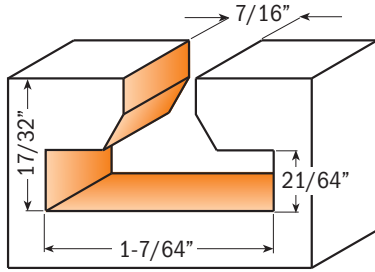
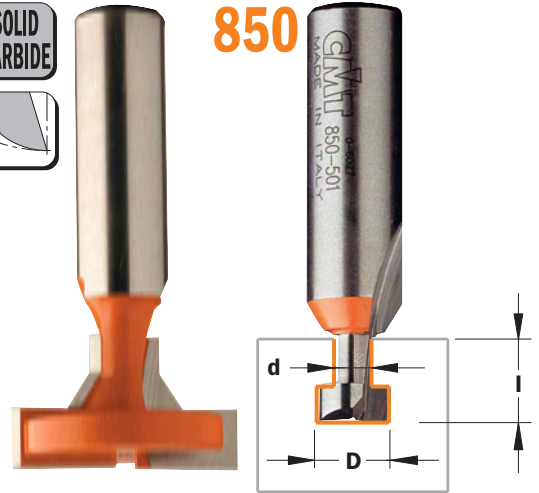
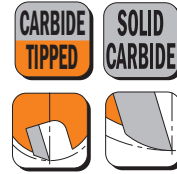

850.603.11

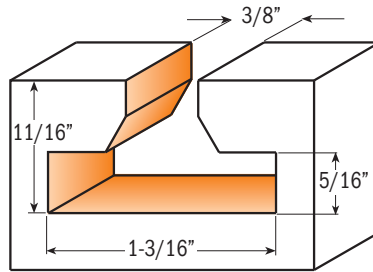

850.601.11

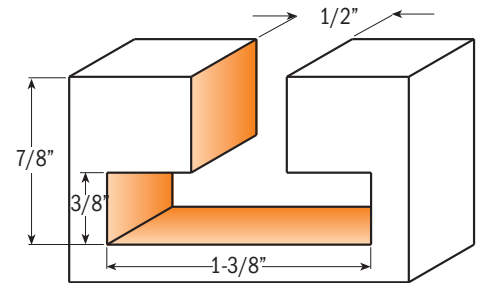

850.602.11

Order No. 1/4" shank	Order No. 1/2" shank	D_Cutting diameter inches	mm	d_Small diameter inches	l_Cutting length inches
850.001.11	850.501.11	3/8	9.52	3/16	7/16
850.603.11	850.603.11	1-7/64	28	7/16	17/32
850.601.11	850.601.11	1-3/16	30	3/8	11/16
850.602.11	850.602.11	1-3/8	34.9	1/2	7/8

NEW

Screw Slot Bit

Any large panel or table top should be secured in a way that allows it to expand or contract without splitting. These screw-slot bits let you create screw slots so that panels can be held in place but are able to slide back and forth without splitting the wood or breaking the screw securing them.

Both have 1/2" shank and the codes 813.701.11 are for countersink screws, while the codes 813.601.11 are for counter-bored screws.

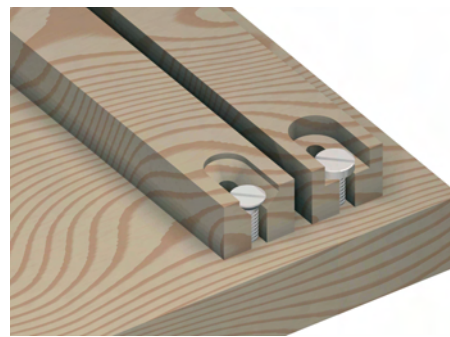

813

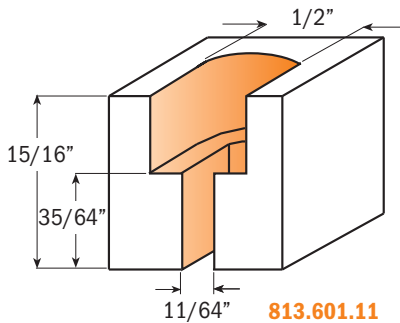

813.601.11

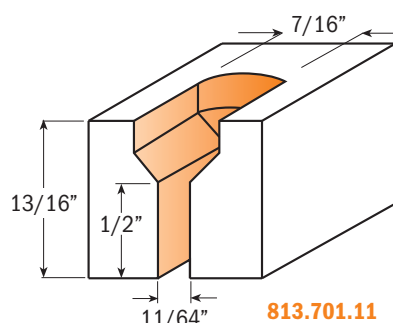

813.701.11

Drawings are 1:1 scale

Order No. 1/2" shank	D_Cutting diameter inches	mm	d_Small diameter inches	l_Cutting length inches	l2_Cutting length inches
813.601.11	1/2	12.7	11/64	15/16	35/64
813.701.11	7/16	11.1	11/64	13/16	1/2

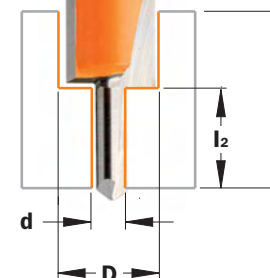

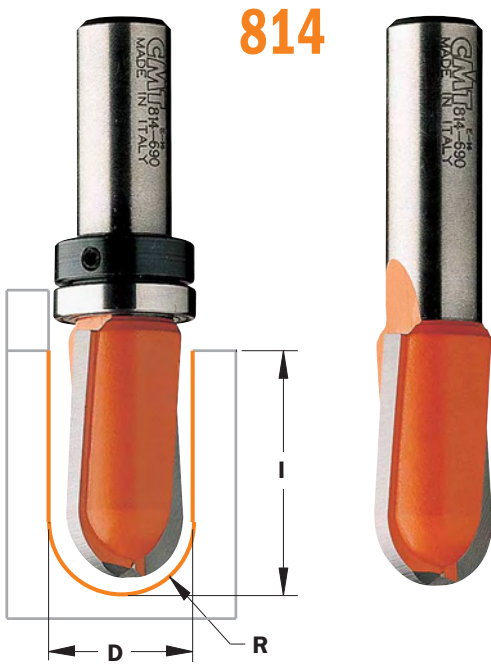

814

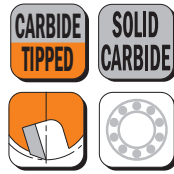

Decorate doors, drawer fronts, panels or any flat surface with CMT Round Nose Bits. These solid carbide or carbide tipped bits let you create grooves in any wood or wood product. For even more elaborate decorations, we also offer top bearing bits - use your own template with one of these bits to produce truly unique doors and drawer fronts. A favorite item for professional sign makers, craft makers and hobbyists.

Safety Precautions:

More than one pass is recommended when making cove edges. To prevent splintering, begin with a shallow initial pass and deepen gradually.

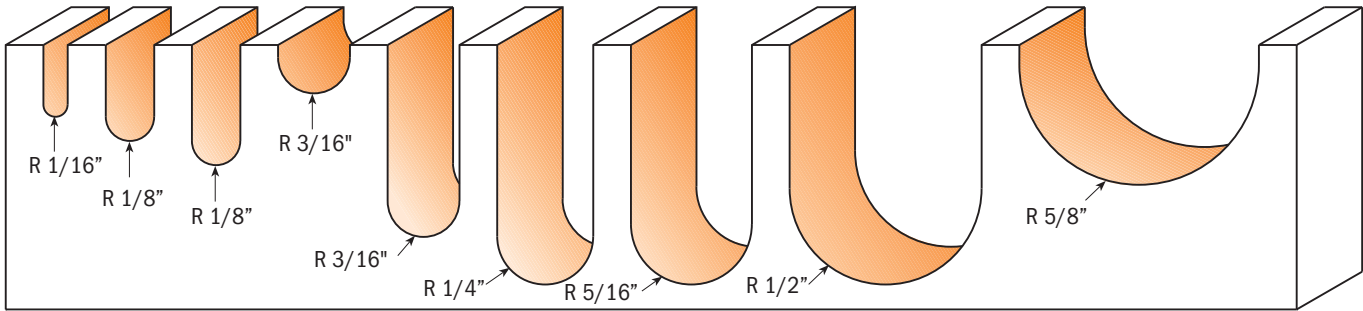
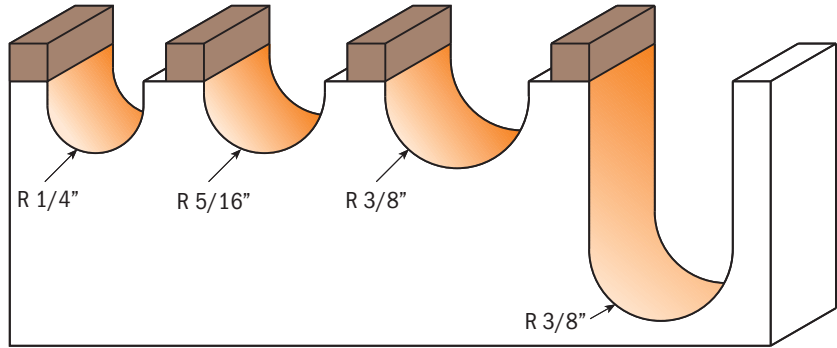

Drawings are 1:1 scale

Order No. 1/4" shank	Order No. 1/2" shank	R_Cutting radius inches	mm	D_Cutting diameter inches	I_Cutting length inches	B_Bearing diameter inches
•814.032.11		1/16	1.6	1/8	3/8	
•814.064.11		1/8	3.2	1/4	1/2	
	•814.564.11	1/8	3.2	1/4	5/8	
814.095.11		3/16	4.75	3/8	1/4	
	814.595.11	3/16	4.75	3/8	1	
814.127.11		1/4	6.35	1/2	3/8	
	814.627.11	1/4	6.35	1/2	1-1/4	
814.160.11		5/16	7.9	5/8	3/8	
	814.660.11	5/16	7.9	5/8	1-1/4	
814.190.11		3/8	9.5	3/4	29/64	
	814.690.11	3/8	9.5	3/4	1-1/4	
	814.754.11	1/2	12.7	1	1-1/4	
	814.817.11	5/8	15.87	1-1/4	3/4	
with top bearing guide						
814.127.11B		1/4	6.35	1/2	3/8	1/2
814.160.11B		5/16	7.9	5/8	3/8	5/8
814.190.11B		3/8	9.52	3/4	29/64	3/4
	814.690.11B	3/8	9.52	3/4	1-1/4	3/4

new

spare parts:

791.010.00	1/2" bearing
791.009.00	5/8" bearing
791.004.00	3/4" bearing (1/4" shank)
791.011.00	3/4" bearing (1/2" shank)
541.001.00	Stop collar for 1/4" shank
541.002.00	Stop collar for 1/2" shank
991.056.00	1.5mm hex key for stop collars

• Solid Carbide

Each of these sets include 3 of the most popular CMT Round Nose Bits. Great for sign making, engraving, or adding flutes and veins to doors or drawer fronts.



814

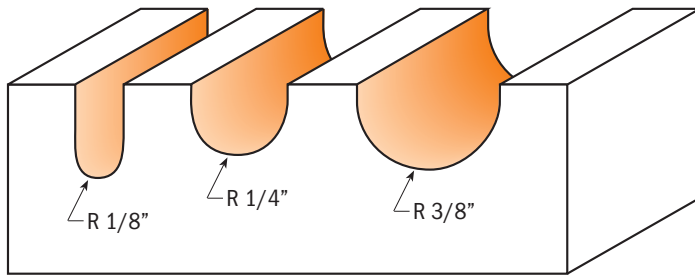

Drawings are 1:1 scale



Order No. 814.001.11 3 piece Round Nose Set 1/4" Shank

Set contains	Order No. 1/4" shank	R_Cutting radius inches	I_Cutting length inches
Round nose bit	814.064.11	1/8	1/2
Round nose bit	814.127.11	1/4	3/8
Round nose bit	814.190.11	3/8	29/64

Order No. 814.501.11 3 piece Round Nose Set 1/2" Shank

Set contains	Order No. 1/2" shank	R_Cutting radius inches	I_Cutting length inches
Round nose bit	814.564.11	1/8	5/8
Round nose bit	814.627.11	1/4	1-1/4
Round nose bit	814.690.11	3/8	1-1/4

Panel Pilot Bits with guide

Spending too much time laying out and cutting openings in paneling, drywall, or siding? Try our Panel Pilot Bits! The point plunges smoothly and easily, then the carbide edges cut clean and fast, delivering accurate cuts in less time and with less effort - also great for trimming formica, veneer and other laminates.



816

Safety Precautions: Always use caution when working near electrical outlets and boxes. Always disconnect the current. Make sure the bit does not go so deep as to cut the wires.

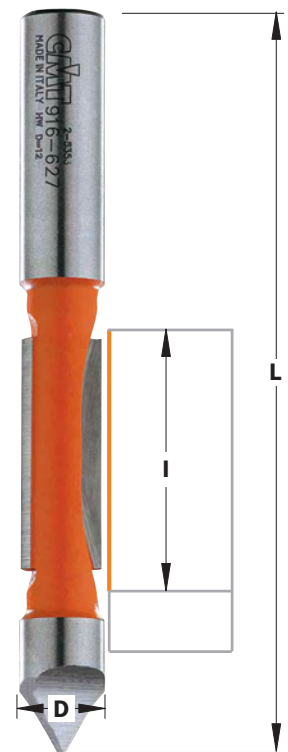
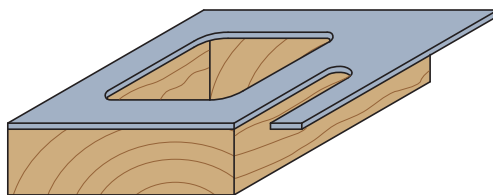

Order No. 1/4" shank	Order No. 1/2" shank	D_Cutting diameter inches	mm	I_Cutting length inches	L_Overall length inches	Z_Nr. of teeth
816.064.11		1/4	6.35	3/4	2-1/2	1
816.095.11		3/8	9.53	1	3-1/16	2
	816.627.11	1/2	12.7	1-1/4	4	2
	816.627.11-X10	10 pcs. in a Masterpack				

90° V-Groove Bits

815



Rout clean, sharp veins in panels or drawer fronts, chamfer edges or engrave beautiful lettering. For almost any bevel job, CMT V-Grooving Bits are a great choice. We also have versatile top bearing bits that let you follow whatever template you choose.

These double cutting edge CMT bits have been especially designed for routing and jointing 90° plasterboard panels but offer you many woodworking possibilities: clean, perfect incisions in panels or drawer fronts, chamfer edges or engraving beautiful lettering. Like all CMT bits, they are made of super strength Fatigue Proof® steel with carbide-tipped cutting edges and are coated with our trademark orange PTFE non-stick coating.

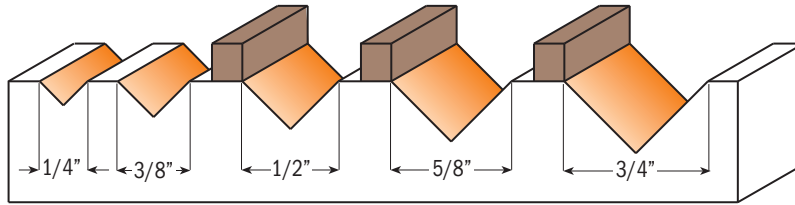
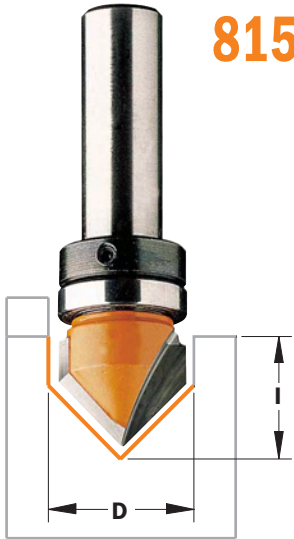

Drawings are 1:1 scale

Order No. 1/4" shank	Order No. 1/2" shank	D_Cutting diameter inches	mm	I_Cutting length inches	A_Cutting angle	B_Bearing diameter inches
•815.064.11		1/4	6.35	5/16	90°	
815.095.11		3/8	9.5	1/2	90°	
815.127.11		1/2	12.7	1/2	90°	
	815.660.11	5/8	15.87	1/2	90°	
	815.690.11	3/4	19	5/8	90°	
	815.817.11	1-1/4	31.7	5/8	90°	
with top bearing guide						
815.127.11B		1/2	12.7	1/2	90°	1/2
	815.690.11B	3/4	19	5/8	90°	3/4
spare parts:						
791.010.00	1/2" bearing					
791.011.00	3/4" bearing					
541.001.00	Stop collar for 1/4" shanks					
541.002.00	Stop collar for 1/2" shanks					
991.056.00	1.5mm hex key for stop collar					

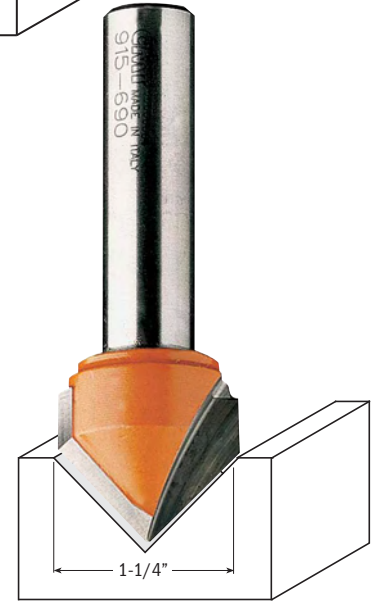

PLASTERBOARD PANEL

• Solid Carbide

60° Laser Point bit

858



These bits produce the sharpest, tightest V-groove effect you'll ever cut with a router. Why do we call them the Laser Point? Because the results are so precise you might think they were cut with a precise beam of laser light. The three super sharp cutting edges allow you to work with superior precision and accuracy. The Laser point makes both a clean 30° bevel and engraves at a 60° angle.

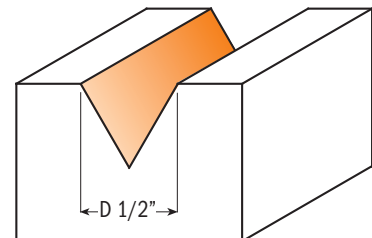
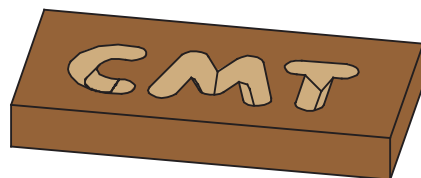
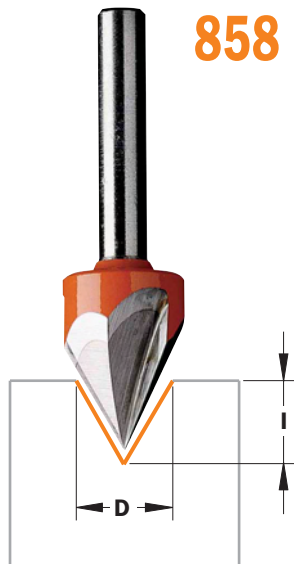

Drawings are 1:1 scale

Order No. 1/4" shank	Order No. 1/2" shank	D_Cutting diameter inches	mm	I_Cutting length inches	A_Cutting angle
858.001.11	858.501.11	1/2	12.7	7/16	60°

Designed specifically for routing signs, these bits have 60° cutting edges, an 1/8" radius and a 1/4"-wide flat bottom. This profile allows you to create striking effects for signmaking while eliminating undesirable chipping and splintering. By putting bevel edges on the raised characters of relief lettering you reduce the possibility of splitting the lettering, which often occurs when producing square relief effects.



849

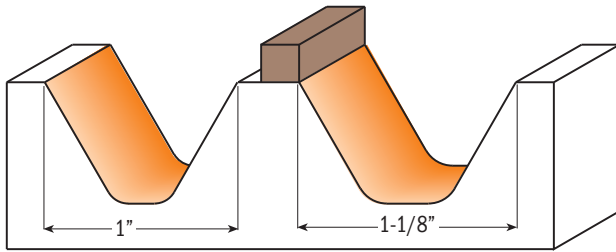

Drawings are 1:1 scale

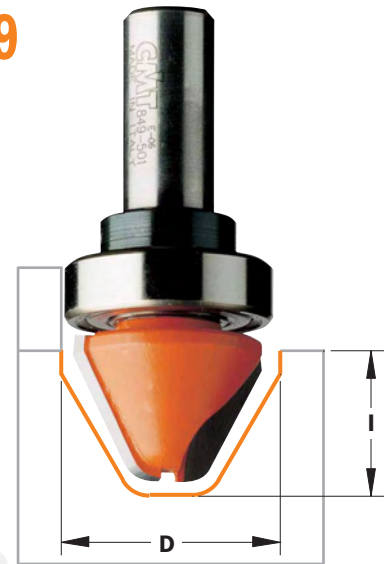

Order No. 1/4" shank	Order No. 1/2" shank	D_Cutting diameter inches mm	I_Cutting length inches	A_Cutting angle	B_Bearing diameter inches
849.001.11		1 25.4	3/4	60°	
	849.501.11	1-1/8 28.5	3/4	60°	
	849.501.11B	1-1/8 28.5	3/4	60°	1-1/8
spare parts:		791.027.00 1-1/8" bearing	991.056.00	1.5mm hex key for stop collar	
	541.002.00	Stop collar for 1/2" shanks			

Bowl & Tray Bits

We call these tools "Bowl and Tray Bits," but you can get lots of work from these bits even if you never rout a bowl or tray. Everybody needs a cutting board, for example, and these bits rout a groove that's perfect for catching meat juice and drippings. Or use them to rout beautiful raised sign lettering, unique boxes, or lots of other specialty or craft items. The round corner of the bit shapes the inner radius while the sides and bottom create the smooth flat surfaces. For best results on jobs where accuracy is a priority we recommend using our top bearing bowl and tray bits.



851

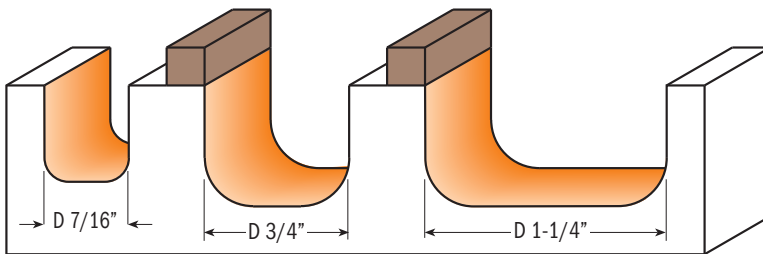

Drawings are 1:1 scale

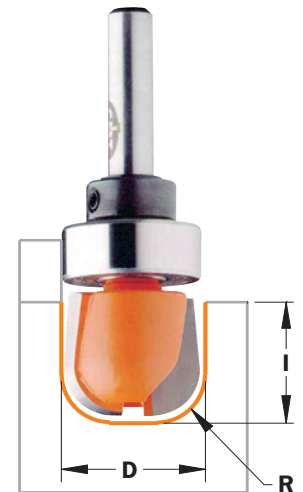

Order No. 1/4" shank	Order No. 1/2" shank	D_Cutting diameter inches mm	I_Cutting length inches	R_Cutting radius inches	B_Bearing diameter inches
851.001.11		7/16 11.1	1/2	1/8	
851.002.11	851.501.11	3/4 19	5/8	1/4	
	851.502.11	1-1/4 31.7	5/8	1/4	
851.002.11B	851.501.11B	3/4 19	5/8	1/4	3/4
	851.502.11B	1-1/4 31.7	5/8	1/4	1-1/4
spare parts:		791.004.00 3/4" bearing (1/4" shank)	541.001.00	Stop collar for 1/4" shanks	
	791.011.00	3/4" bearing (1/2" shank)		541.002.00	Stop collar for 1/2" shanks
	791.015.00	1-1/4" bearing (1/2" shank)		991.056.00	1.5mm hex key for stop collar

Multi-Purpose Rabbeting Bits



835



Get seven different rabbets from one bit - and all for just a little more than the cost of the bit itself. Each set includes a bit and seven bearings.

791.703.00



Order No. 1/4" shank	Order No. 1/2" shank	H_Cutting depth inches	mm	D_Cutting diameter inches	I_Cutting length inches
835.001.11	835.501.11	1/8 to 1/2	3.2-12.7	1-3/8	1/2
	835.502.11	1/8 to 1/2	3.2-12.7	1-3/8	3/4

spare parts: 791.703.00 Bearing set

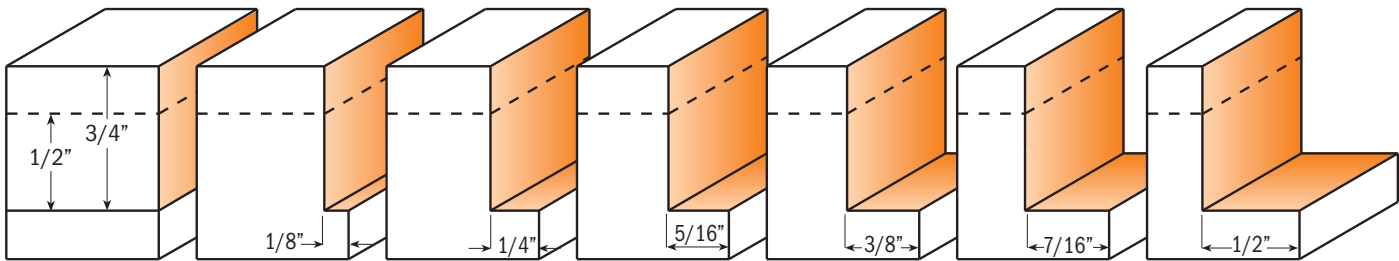

Drawings are 1:1 scale

Rabbeting Bits

835



For versatility in the workshop or on the job, it is very tough to beat CMT's carbide tipped rabbeting bits. With one of these tools you can quickly produce inset doors and drawer fronts, make strong rabbet joints, mill perfect tongue and groove joints and much more! For the greatest capacity, choose our extra-long 3/4" rabbeting bit; it even allows you to re-groove old window frames to accept insulated glass panes.

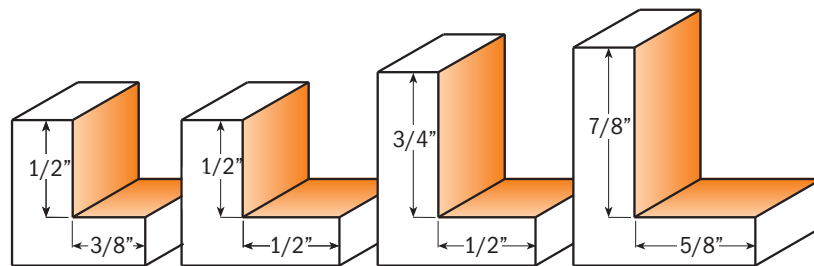
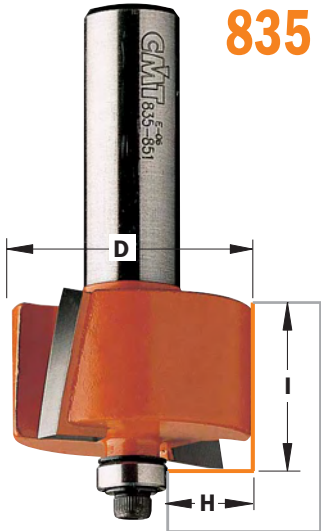

Drawings are 1:1 scale

Order No. 1/4" shank	Order No. 1/2" shank	H_Cutting depth inches	mm	D_Cutting diameter inches	I_Cutting length inches	B_Bearing diameter inches
835.317.11	835.817.11	3/8	9.52	1-1/4	1/2	1/2
835.350.11	835.850.11	1/2	12.7	1-3/8	1/2	3/8
	835.851.11	1/2	12.7	1-3/8	3/4	3/8
	835.990.11	5/8	15.87	2	7/8	3/4

spare parts:

990.422.00	3/8" shield
990.423.00	1/2" shield
791.002.00	3/8" bearing
791.003.00	1/2" bearing
791.010.00	1/2" bearing (for 835.990)
799.503.00	3/4" collar
990.058.00	Screw for bearing, 1/8x3/8"
991.057.00	3/32" hex key for 1/8W screws

The ultimate rabbeting set & the ultimate tool value. This set includes our 835.990.11 bit with 7/8" cutting height, plus bearings to cut 17 different rabbets, all in a sturdy molded case.



Order No. 835.503.11 CMT Grand Rabbet Set 1/2" Shank

Order No. 1/2" shank	Set contains
835.990.11	rabbeting bit (2"x7/8")
791.705.00	5 pcs. collar set (1/16"-1/8"-1/4"-3/8"-1/2" rabbets)
791.706.00	5 pcs. collar set (3/16"-5/16"-7/16"-9/16"-11/16" rabbets)
791.707.00	5 pcs. collar set (15/64"-23/64"-15/32"-19/32"-23/32" rabbets)
spare parts: 799.517.00	2" Flush Trim

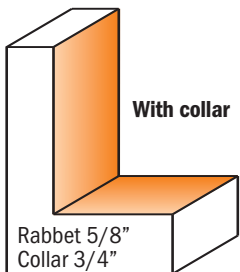
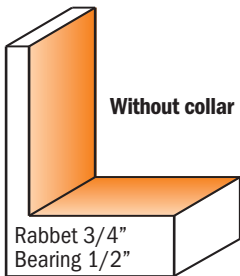
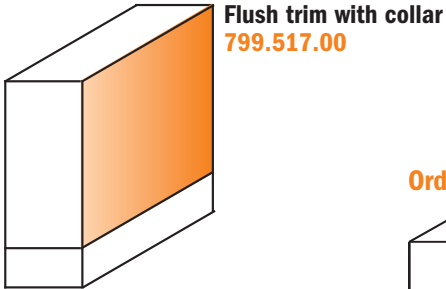
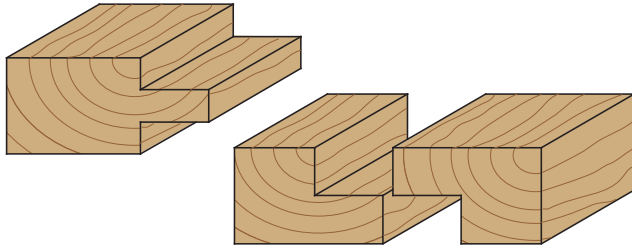
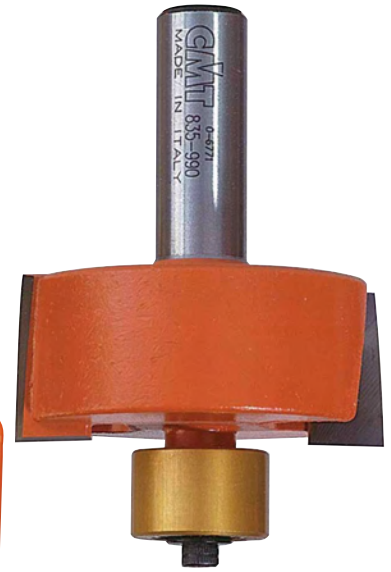

Order No. 791.705.00

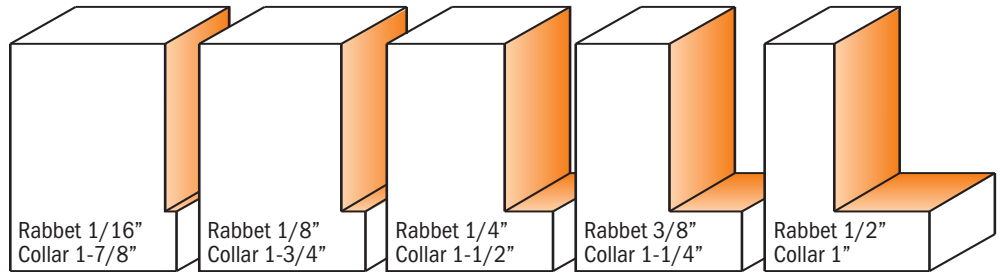

Order No. 791.706.00

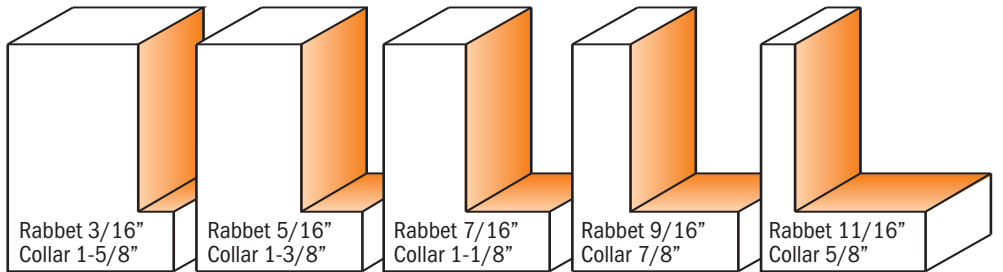

Order No. 791.707.00

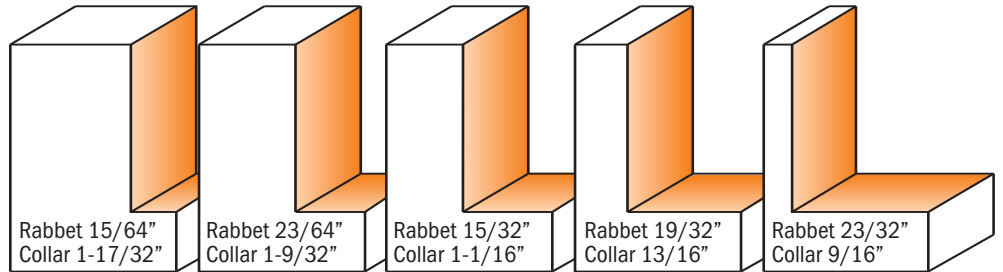

Drawings are 1:1 scale

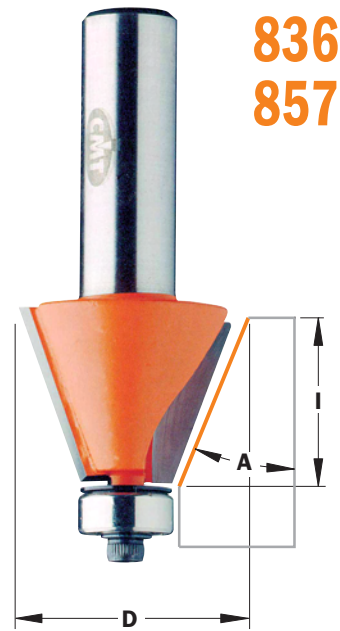

836
857



CMT Chamfer Bits cut clean, accurate bevels and chamfers that are great for edge work or to make perfectly aligned multi-sided containers, boxes and other decorative projects. See illustration below for examples. Can be used to work larger scale projects such as beams and columns with excellent results.

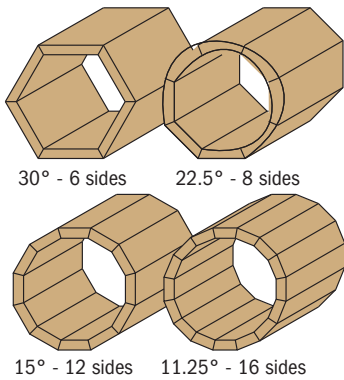
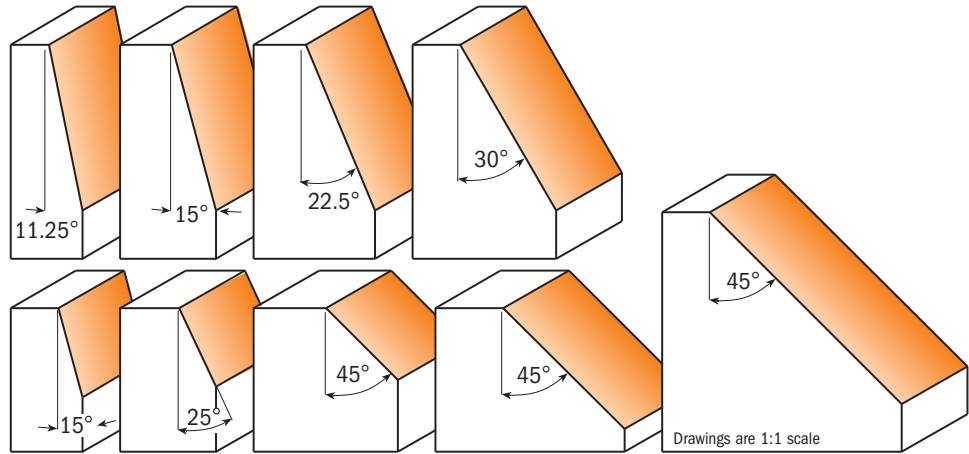

Order No. 1/4" shank	Order No. 1/2" shank	D_Cutting diameter inches	mm	A_Cutting angle	I_Cutting length inches	B_Bearing diameter inches
836.130.11		3/4	19.05	15°	7/16	1/2
836.190.11		7/8	22.2	25°	13/32	1/2
836.280.11		1-1/4	31.7	45°	3/8	1/2
836.420.11	836.920.11	1-3/4	44.5	45°	5/8	1/2
	836.950.11	2-9/16	65	45°	1	1/2
	857.504.11	7/8	22.2	11.25°	7/8	1/2
	857.503.11	1	25.4	15°	7/8	1/2
	857.502.11	1-1/4	31.7	22.5°	7/8	1/2
	857.501.11	1-1/2	38.1	30°	7/8	1/2
spare parts:		990.423.00	1/2" shield	990.058.00	Screw for bearing, 1/8Wx3/8"	
		791.003.00	1/2" bearing	991.057.00	3/32" hex key for 1/8W screws	

5 piece Chamfer Bit Set

836.501



Build beautiful planters, boxes and other multi-sided pieces with this handy set. Why cut imperfect angles on your table saw when it's so much easier and accurate to use the CMT Chamfer Set? Our solution to accurate polygon construction

includes 5 anti-kickback, carbide tipped bits in the most popular angles - 11.25°, 15°, 22.5°, 30° and 45°.

No polygon project is too difficult. Available with 1/2" shank.

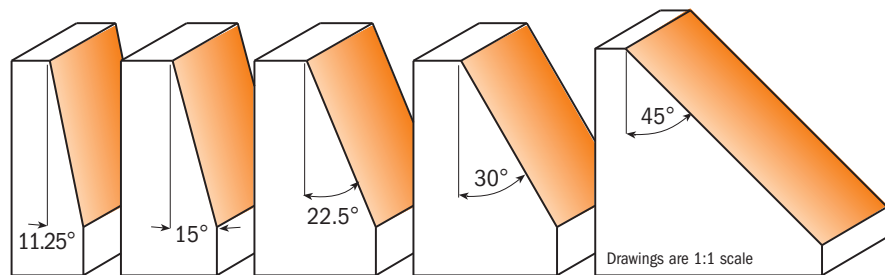

Order No. **836.501.11** 5 piece Chamfer Bit Set 1/2" Shank

Set contains	Order No. 1/2" shank	A_Cutting angle inches	D_Cutting diameter inches
Chamfer bit	857.504.11	11.25°	7/8
Chamfer bit	857.503.11	15°	1
Chamfer bit	857.502.11	22.5°	1-1/4
Chamfer bit	857.501.11	30°	1-1/2
Chamfer bit	836.920.11	45°	1-3/4

An angled plastic sleeve on the bearing of the CMT Bevel Cutter lets you work without leaving marks on the workpiece. Trims and shapes all wood and solid surface materials. Perfect for kitchen and bathroom counter top work.



866.5

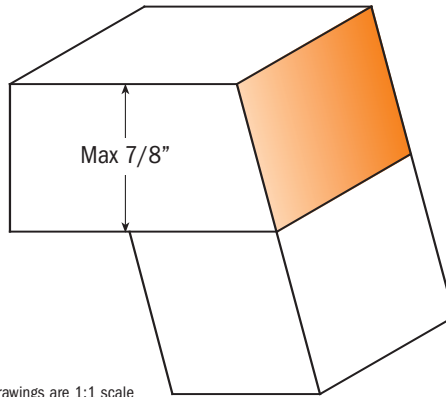

Drawings are 1:1 scale

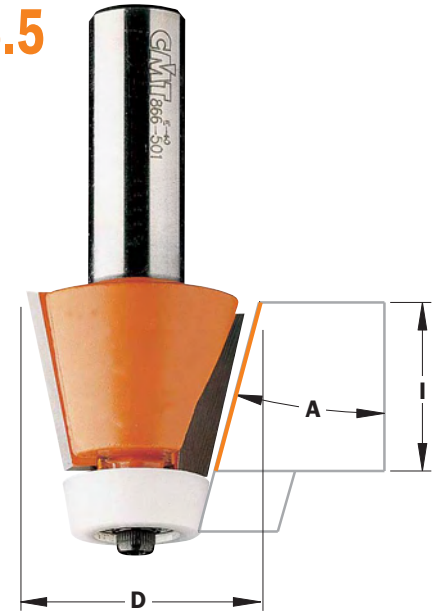

Order No.	D_Cutting diameter	A_Cutting angle	I_Cutting length	B_Bearing diameter	
1/2" shank	inches	mm	inches	inches	
866.501.11	1-1/4	31.7	15°	7/8	3/4
spare parts:	791.041.00	3/4" - 10° bearing			
	990.058.00	Screw for bearing, 1/8Wx3/8"			
	991.057.00	3/32" hex key for 1/8W screws			

Solid Surface Bowl Bits

One of the most popular profiles for working with solid surface materials, this bit also features a plastic sleeve on the bearing to protect sensitive surfaces.



866.6

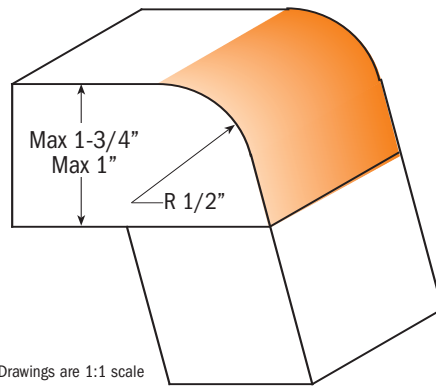

Drawings are 1:1 scale

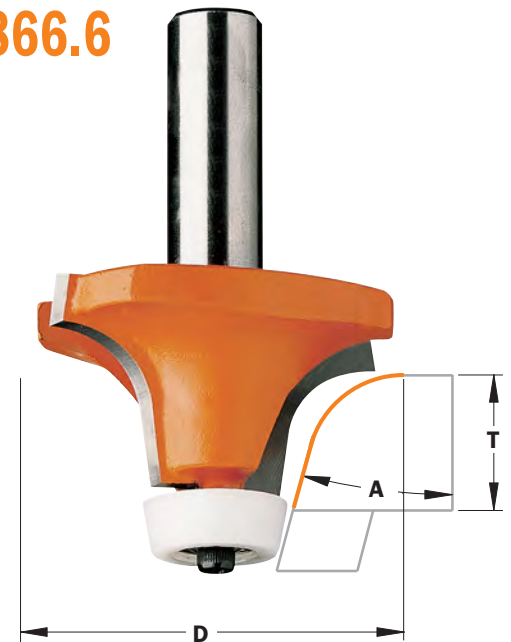

Order No.	T_Stock thickness	A_Cutting angle	D_Cutting diameter	B_Bearing diam.	
1/2" shank	inches	mm	inches	inches	
866.601.11	3/4	19	15°	2	3/4
866.602.11	1	25.4	15°	2	3/4
spare parts:	791.041.00	3/4" - 10° bearing			
	990.058.00	Screw for bearing, 1/8Wx3/8"			
	991.057.00	3/32" hex key for 1/8W screws			

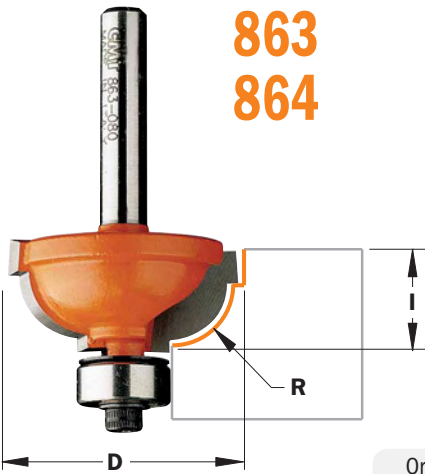

863
864



The Cavetto Bit cuts a beautiful, traditional profile, or use just a portion of the bit to cut a more simple, clean cove edge. Adds a special touch to furniture pieces.

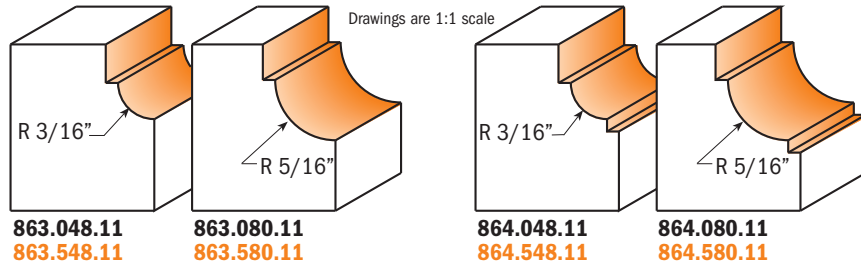

863.048.11
863.548.11

863.080.11
863.580.11

864.048.11
864.548.11

864.080.11
864.580.11

Order No. 1/4" shank	Order No. 1/2" shank	R_Cutting radius inches	mm	D_Cutting diameter inches	I_Cutting length inches	B_Bearing diameter inches
863.048.11	863.548.11	3/16	4.76	1	29/64	1/2
863.080.11	863.580.11	5/16	8	1-1/4	9/16	1/2
864.048.11	864.548.11	3/16	4.76	1	29/64	3/8
864.080.11	864.580.11	5/16	8	1-1/4	9/16	3/8
spare parts:		990.422.00	3/8" shield	791.003.00	1/2" bearing	
		990.423.00	1/2" shield	990.058.00	Screw for bearing, 1/8W x 3/8"	
		791.002.00	3/8" bearing	991.057.00	3/32" hex key for 1/8W screws	

Ovolo Bits

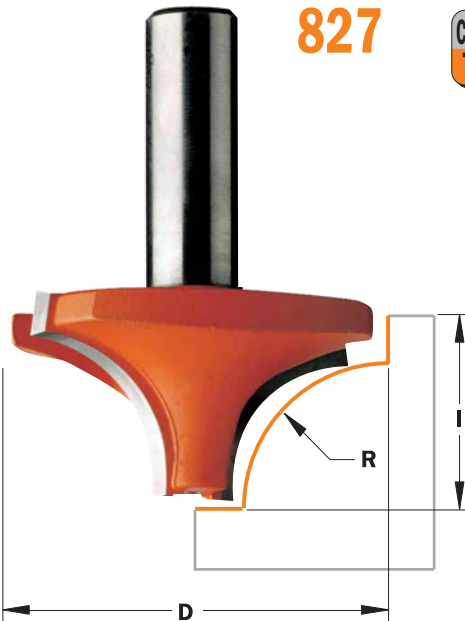

827



An ideal bit for furniture makers, CMT's Ovolo Bits are actually several bits in one. Use the Ovolo to create unusual grooves and veins, as well as clean roundover and bead edges. These bits should be used with a router edge guide, router table with fence or on automated router systems.

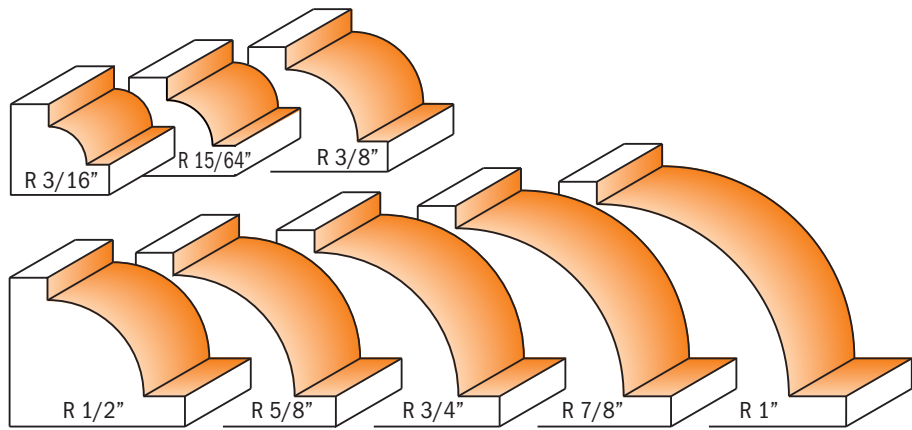

Drawings are 1:1 scale

Order No. 1/4" shank	Order No. 1/2" shank	R_Cutting radius inches	mm	D_Cutting diameter inches	I_Cutting length inches
827.050.11		3/16	5	13/16	15/32
827.060.11	827.560.11	15/64	6	29/32	15/32
827.095.11	827.595.11	3/8	9.52	1-1/4	9/16
827.127.11	827.627.11	1/2	12.7	1-1/2	3/4
	827.660.11	5/8	15.9	1-3/4	7/8
	827.690.11	3/4	19	2	1
	827.722.11	7/8	22.2	2-1/4	1-1/8
	827.754.11	1	25.4	2-1/2	1-5/16

Transform furniture, doors, and drawer fronts from simple to elegant by giving them a final touch with a CMT Cove Bit. Put these bits together with a CMT Roundover Bit and build perfectly fitting rule joints that are ideal for drop leaf table tops.



837

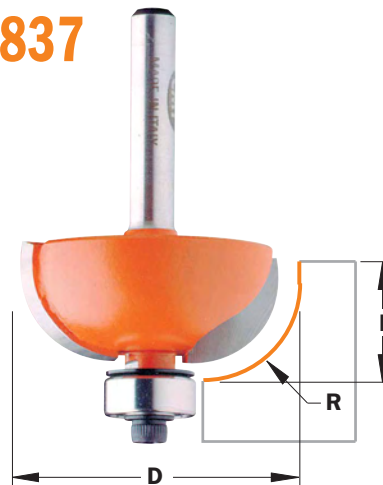

Order No. 1/4" shank	Order No. 1/2" shank	R_Cutting radius inches	D_Cutting diameter mm	I_Cutting length inches	B_Bearing diameter inches
837.190.11	837.690.11	3/16	4.75	7/8	1/2
837.222.11	837.722.11	1/4	6.35	1	1/2
837.254.11	837.754.11	5/16	8	1-1/8	1/2
837.286.11	837.786.11	3/8	9.52	1-1/4	1/2
837.350.11	837.850.11	1/2	12.7	1-1/2	1/2
	837.950.11	5/8	15.87	1-3/4	1/2
	837.951.11	3/4	19	2	1/2
	837.955.11			2	1/2

spare parts: 990.423.00 1/2" shield
791.003.00 1/2" bearing
990.058.00 Screw for bearing, 1/8W x 3/8"

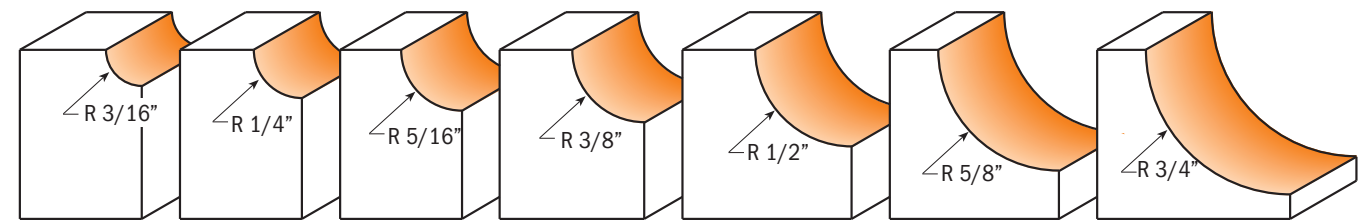
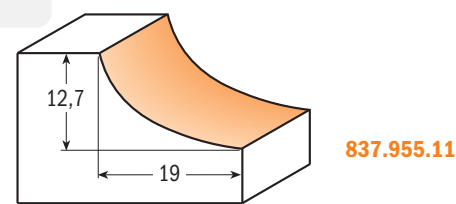

Drawings are 1:1 scale

Cove Bits Sets

Each of these sets include carbide Cove Bits in three of the most commonly-used sizes. You'll get 1/4", 3/8" and 1/2" radius bits in your choice of 1/4" or 1/2" shank.



837

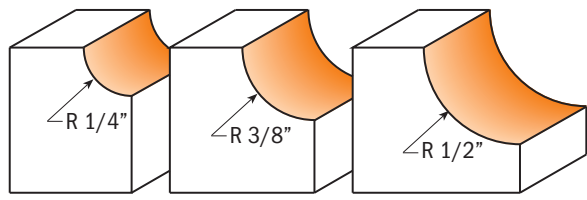

Drawings are 1:1 scale



Order No. 837.001.11 3 piece Cove Bit Set 1/4" Shank

Set contains	Order No. 1/4" shank	R_Cutting radius inches	I_Cutting length inches
Cove bit	837.222.11	1/4	1/2
Cove bit	837.286.11	3/8	1/2
Cove bit	837.350.11	1/2	5/8

Order No. 837.501.11 3 piece Cove Bit Set 1/2" Shank

Set contains	Order No. 1/2" shank	R_Cutting radius inches	I_Cutting length inches
Cove bit	837.722.11	1/4	1/2
Cove bit	837.786.11	3/8	1/2
Cove bit	837.850.11	1/2	5/8

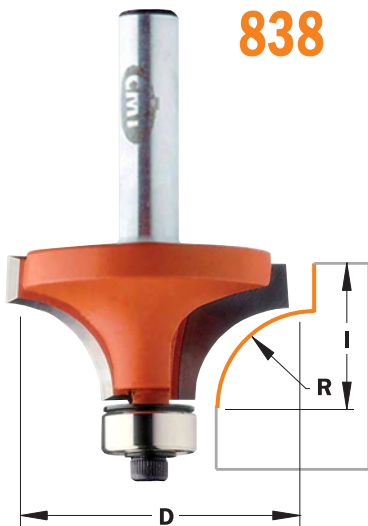

838



It's hard to find a profile bit that gets more work than a Roundover Bit. This shape is great for simple tasks like easing sharp corners, or for more intricate jobs like drop leaf tables (when used in conjunction with our Cove Bits of the same radius).

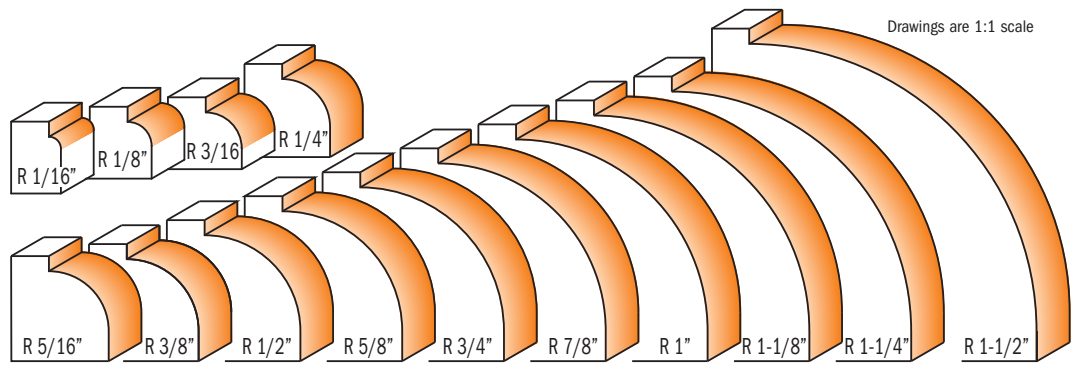

Drawings are 1:1 scale

Order No. 1/4" shank	Order No. 1/2" shank	R_Cutting radius inches	R_Cutting radius mm	D_Cutting diameter inches	I_Cutting length inches	B_Bearing diameter inches
838.160.11		1/16	1.6	5/8	1/2	1/2
838.190.11		1/8	3.2	3/4	1/2	1/2
838.222.11		3/16	4.75	7/8	1/2	1/2
838.254.11	838.754.11	1/4	6.35	1	1/2	1/2
838.285.11		5/16	7.95	1-1/8	1/2	1/2
838.317.11	838.817.11	3/8	9.52	1-1/4	9/16	1/2
838.380.11	838.880.11	1/2	12.7	1-1/2	3/4	1/2
838.445.11	838.945.11	5/8	15.9	1-3/4	7/8	1/2
	838.990.11	3/4	19	2	1	1/2
	838.991.11	7/8	22.2	2-1/4	1-1/8	1/2
	838.992.11*	1	25.4	2-1/2	1-5/16	1/2
	838.993.11*	1-1/8	28.6	3	1-1/2	3/4
	838.994.11*	1-1/4	31.7	3-1/4	1-3/4	3/4
	838.996.11*	1-1/2	38.1	3-1/2	1-3/4	1/2

spare parts:

990.423.00	1/2" shield	990.058.00	Screw for bearing, 1/8W x 3/8"
791.003.00	1/2" bearing	991.057.00	3/32" hex key for 1/8W screws
791.004.00	3/4" bearing		

* Use on router tables only



Roundover Sets

838.001

838.501



CMT's Roundover Sets give you the maximum flexibility for all of your projects by putting the most requested diameters in one package. Available in 1/2" and 1/4" shanks. Roundover radii are 1/4", 3/8" and 1/2".

These versatile bits are always in demand - the simple clean lines of a smooth roundover edge can be used in a wide variety of applications from picture frames to table and counter tops.

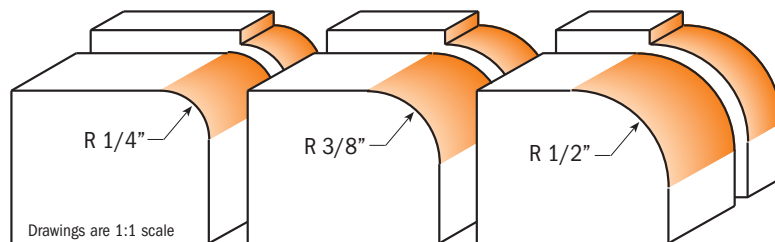

Drawings are 1:1 scale

Order No. **838.001.11** 3 piece Roundover Bit Set 1/4" Shank

Set contains	Order No. 1/4" shank	R_Cutting radius inches	I_Cutting length inches
Roundover bit	838.254.11	1/4	1/2
Roundover bit	838.317.11	3/8	9/16
Roundover bit	838.380.11	1/2	3/4

Order No. **838.501.11** 3 piece Roundover Bit Set 1/2" Shank

Set contains	Order No. 1/2" shank	R_Cutting radius inches	I_Cutting length inches
Roundover bit	838.754.11	1/4	1/2
Roundover bit	838.817.11	3/8	9/16
Roundover bit	838.880.11	1/2	3/4

Beading Bits are similar to the Roundover profile, but a smaller bearing produces a delicate inset at the base of the cut, giving you an extra decorative option.



839

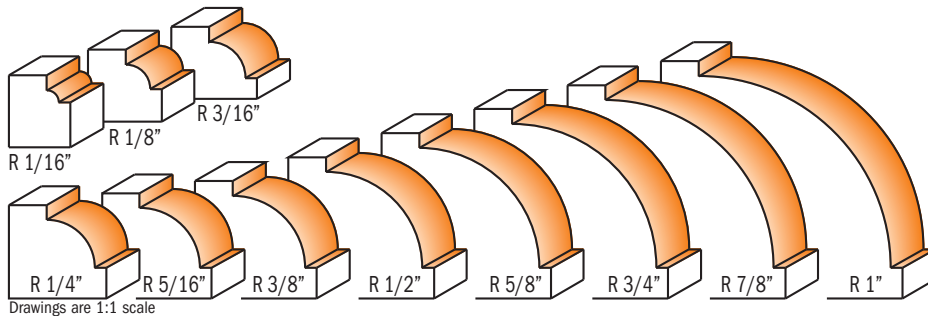
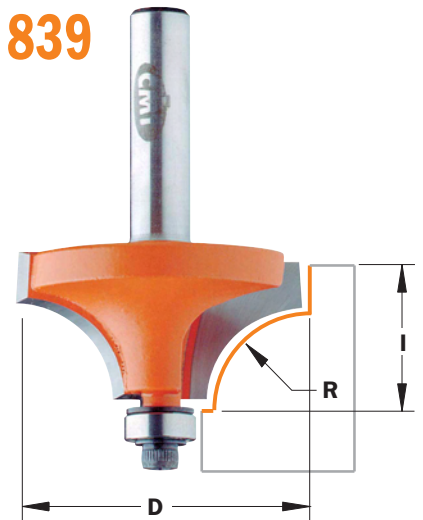

Drawings are 1:1 scale

Order No. 1/4" shank	Order No. 1/2" shank	R_Cutting radius inches	mm	D_Cutting diameter inches	I_Cutting length inches	B_Bearing diameter inches
839.160.11		1/16	1.6	5/8	1/2	3/8
839.190.11		1/8	3.2	3/4	1/2	3/8
839.222.11		3/16	4.75	7/8	1/2	3/8
839.254.11	839.754.11	1/4	6.35	1	1/2	3/8
839.285.11		5/16	7.95	1-1/8	1/2	3/8
839.317.11	839.817.11	3/8	9.52	1-1/4	9/16	3/8
839.380.11	839.880.11	1/2	12.7	1-1/2	3/4	3/8
839.445.11	839.945.11	5/8	15.87	1-3/4	7/8	3/8
	839.990.11	3/4	19	2	1	3/8
	839.991.11	7/8	22.2	2-1/4	1-1/8	3/8
	839.992.11*	1	25.4	2-1/2	1-5/16	3/8
spare parts:		990.422.00	3/8" shield	990.058.00	Screw for bearing, 1/8W x 3/8"	
		791.002.00	3/8" bearing	991.057.00	3/32" hex key for 1/8W screws	

* Use on router tables only

Bull Nose Bits

Bull Nose Bits are the perfect choice for the edges of stair treads, window sills, shelves and more. Or create an oval edge by using a bit with a bead diameter greater than the stock thickness. All bits feature anti-kickback design and CMT's trademark orange Teflon® Industrial Coating.



854



Order No. 1/4" shank	Order No. 1/2" shank	R_Cutting radius inches	mm	_Bead length inches	I_Cutting length inches	D_Cutting diameter inches
854.002.11	854.502.11	1/8	3.2	1/4	3/4	7/8
854.003.11	854.503.11	3/16	4.75	3/8	7/8	1
854.004.11	854.504.11	1/4	6.35	1/2	1	1-1/8
	854.507.11	3/8	9.52	3/4	1-3/8	1-3/8
	854.509.11	1/2	12.7	1	1-5/8	1-3/4

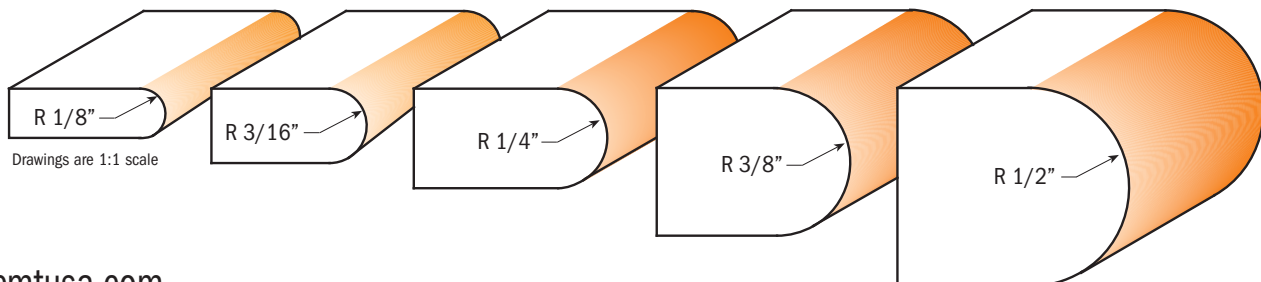

Drawings are 1:1 scale

Corner Beading Bits

861



Corner Beading bits look like Bull Nose bits, but a smaller cutting diameter adjacent to the bearing makes them a perfect shape for table legs and other furniture details. The drawings below give a sense of the shapes you can form with a single bit. Use one pass to mill an attractive rounded edge, or make two passes to mill a full-round corner bead.

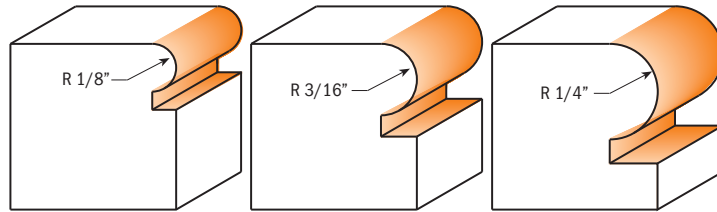
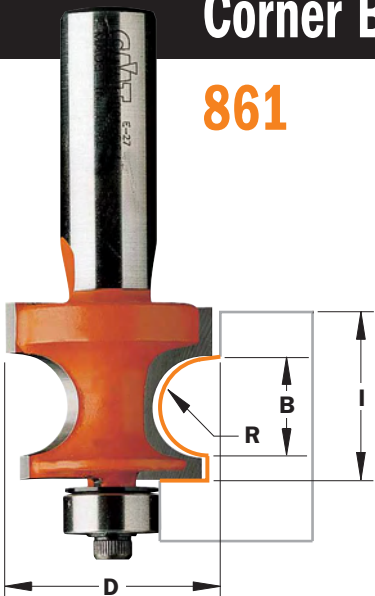

Drawings are 1:1 scale

Order No. 1/4" shank	Order No. 1/2" shank	R_Cutting radius inches	mm	_Bead length inches	I_Cutting length inches	D_Cutting diameter inches	B_Bearing diameter inches
861.032.11	861.532.11	1/8	3.2	1/4	19/32	7/8	1/2
861.048.11	861.548.11	3/16	4.75	3/8	47/64	1	1/2
861.064.11	861.564.11	1/4	6.35	1/2	7/8	1-1/8	1/2
spare parts:		990.423.00	1/2" shield		990.058.00	Screw for bearing, 1/8W x 3/8"	
		791.003.00	1/2" bearing		991.057.00	3/32" hex key for 1/8W screws	

Molding Bits

867.5



These Molding Bits feature inverted profiles that are ideal for use with a router table. Instead of running stock with the edge to be routed down on the table, the flat surface of the stock can remain on the table. These bits are also key ingredients in our Crown Molding Set.

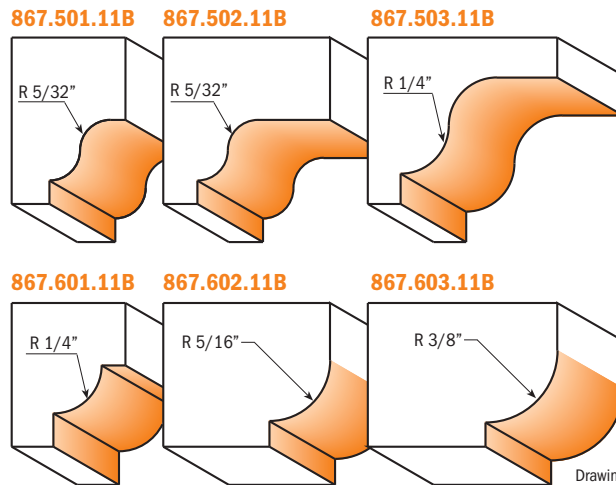
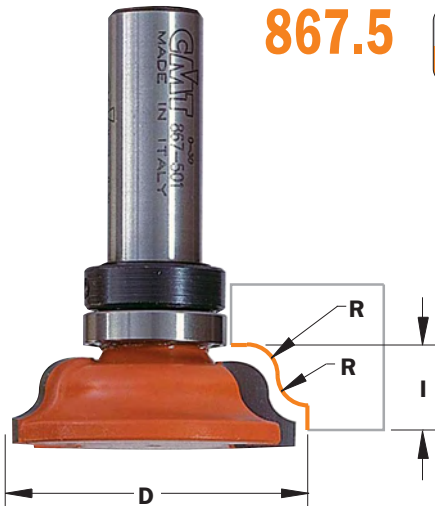

Drawings are 1:1 scale

Order No. 1/2" shank	R_Cutting radius inches	mm	D_Cutting diameter inches	I_Cutting length inches	B_Bearing diam. inches
867.501.11B	5/32	4	1-9/16	29/64	3/4
867.502.11B	5/32	4	2-1/8	29/64	3/4
867.503.11B	1/4	6.35	2-3/8	11/16	3/4
867.601.11B	1/4	6.35	1-1/2	31/64	3/4
867.602.11B	5/16	8	1-3/8	33/64	3/4
867.603.11B	3/8	9.52	1-1/2	37/64	3/4
spare parts:		791.011.00	3/4" bearing		
		541.002.00	Stop collar for Ø12.7mm shank		
		991.056.00	1.5mm allen key for stop collars		

This beautiful, graceful shape is always a popular edge treatment, so a fine Roman Ogee Bit should be a staple of any woodworker's shop. The CMT Roman Ogee Bit includes all of the great CMT features, producing a perfect rendition of a classic design.



840

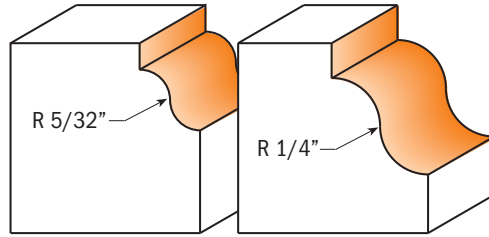

Drawings are 1:1 scale

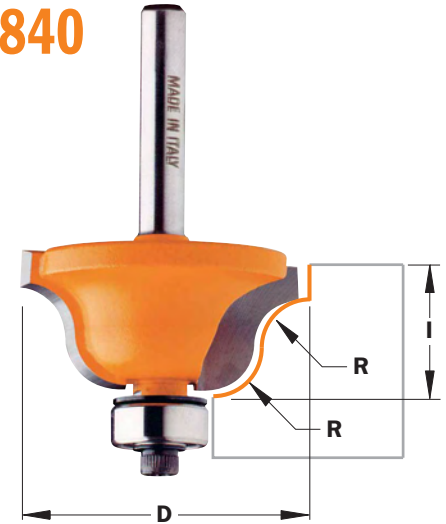

Order No. 1/4" shank	Order No. 1/2" shank	R_Cutting radius inches	mm	D_Cutting diameter inches	I_Cutting length inches	B_Bearing diameter inches
840.270.11	840.770.11	5/32	4	1-1/8	29/64	1/2
840.350.11	840.850.11	1/4	6.35	1-1/2	11/16	1/2
spare parts:		990.423.00	1/2" shield	990.058.00	Screw for bearing, 1/8W x 3/8"	
		791.003.00	1/2" bearing	991.057.00	3/32" hex key for 1/8W screws	

Classical Ogee Bits

This bit takes the Roman ogee a step further, with a horizontal bead in the middle of the profile to add more interest to the shape. This bit is appropriate for many classical projects that need more detail in the edge.



841

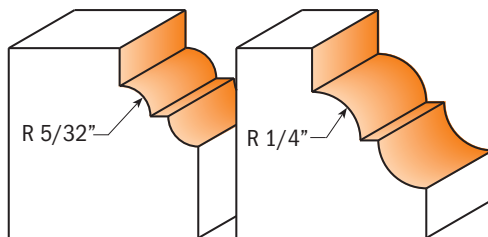

Drawings are 1:1 scale

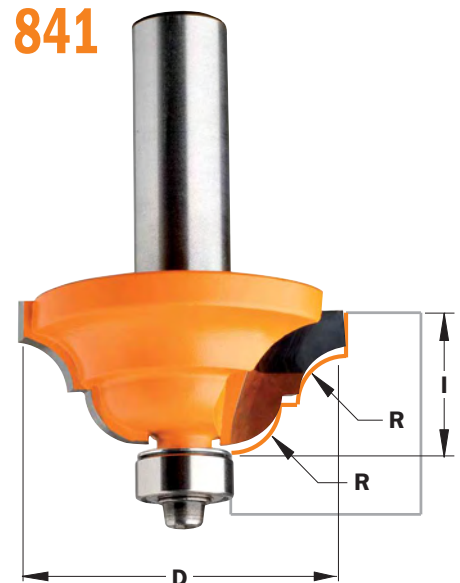

Order No. 1/4" shank	Order No. 1/2" shank	R_Cutting radius inches	mm	D_Cutting diameter inches	I_Cutting length inches	B_Bearing diameter inches
841.285.11	841.785.11	5/32	4	1-5/16	1/2	1/2
841.380.11	841.880.11	1/4	6.35	1-11/16	3/4	1/2
spare parts:		990.423.00	1/2" shield	990.058.00	Screw for bearing, 1/8W x 3/8"	
		791.003.00	1/2" bearing	991.057.00	3/32" hex key for 1/8W screws	

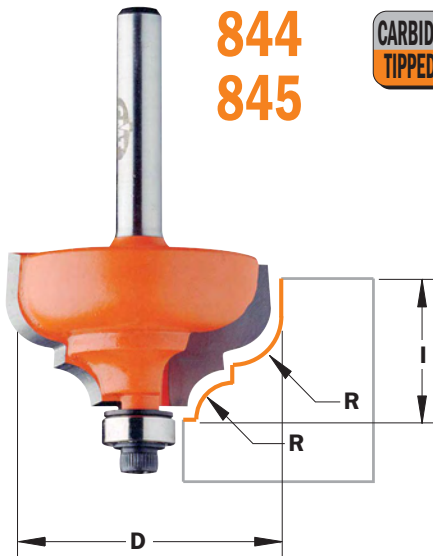

844
845



Our Classical Ogee Bits feature an inverted ogee profile, with the concave edge adjacent to the upper surface of the workpiece. These bits further define the edge with a horizontal bead along the bottom of the cut.

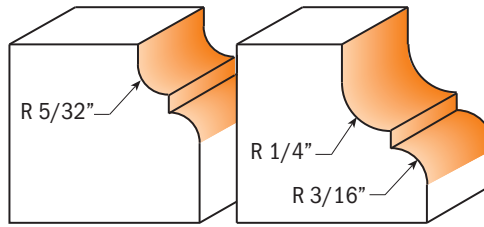

844.287.11
844.787.11

844.350.11
844.850.11

Drawings are 1:1 scale

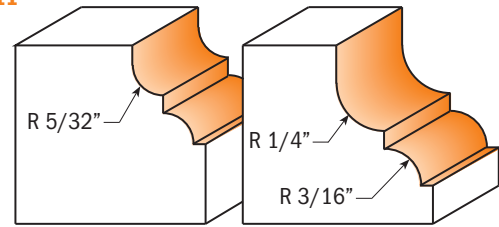

845.287.11
845.787.11

845.350.11
845.850.11

Order No. 1/4" shank	Order No. 1/2" shank	R_Cutting radius inches	D_Cutting diameter mm	I_Cutting length inches	B_Bearing diameter inches
844.287.11	844.787.11	5/32	4	1-1/8	1/2
844.350.11	844.850.11	1/4-3/16	6.35-4.8	1-3/8	1/2
845.287.11	845.787.11	5/32	4	1-1/8	3/8
845.350.11	845.850.11	1/4-3/16	6.35-4.8	1-3/8	3/8
spare parts:		990.422.00	3/8" shield	791.003.00	1/2" bearing
		990.423.00	1/2" shield	990.058.00	Screw for bearing, 1/8W x 3/8"
		791.002.00	3/8" bearing	991.057.00	3/32" hex key for 1/8W screws

Ogee with Fillet Bits



846
847



Give your shop a full range of options with a complete assortment of CMT Ogee Bits. All CMT bits feature micrograin carbide edges, high-strength European steel and our trademark orange coating. For a more-detailed version of this beautiful profile, the 847-series bit adds an inset bead along the lower edge of the cut.

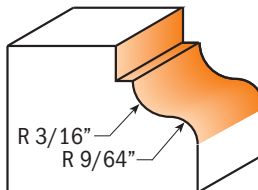

846.325.11
846.825.11

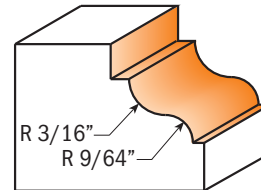

847.325.11
847.825.11

Drawings are 1:1 scale

Order No. 1/4" shank	Order No. 1/2" shank	R_Cutting radius inches	D_Cutting diameter mm	I_Cutting length inches	B_Bearing diameter inches
846.325.11	846.825.11	3/16-9/64	4.8-3.6	1-3/8	1/2
847.325.11	847.825.11	3/16-9/64	4.8-3.6	1-3/8	3/8
spare parts:		990.422.00	3/8" shield	791.003.00	1/2" bearing
		990.423.00	1/2" shield	990.058.00	Screw for bearing, 1/8W x 3/8"
		791.002.00	3/8" bearing	991.057.00	3/32" hex key for 1/8W screws

These profiles are the mirror image of the traditional Roman ogee. They add a sharp defining detail to the edges of cabinets and furniture before rolling into a smooth convex shape. For an extra inset bead along the lower edge of the cut choose the Ogee with Inset Bead bits (860 series).



859
860

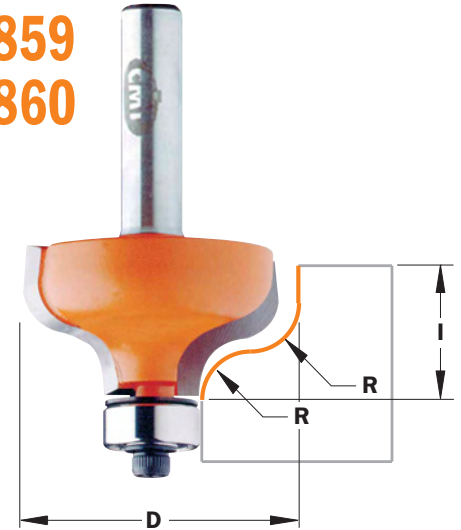
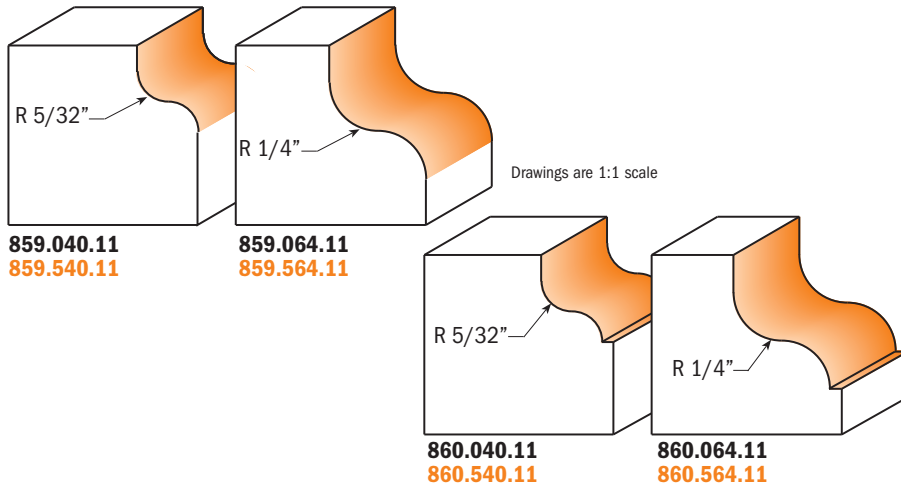

Order No. 1/4" shank	Order No. 1/2" shank	R_Cutting radius inches	D_Cutting diameter mm	I_Cutting length inches	B_Bearing diameter inches
859.040.11	859.540.11	5/32	4	1-1/8	1/2
859.064.11	859.564.11	1/4	6.35	1-1/2	1/2
860.040.11	860.540.11	5/32	4	1-1/8	3/8
860.064.11	860.564.11	1/4	6.35	1-1/2	3/8
spare parts:		990.422.00	3/8" shield	791.003.00	1/2" bearing
		990.423.00	1/2" shield	990.058.00	Screw for bearing, 1/8W x 3/8"
		791.002.00	3/8" bearing	991.057.00	3/32" hex key for 1/8W screws

Plunge Ogee Bits

You will never run out of clever, creative applications for this bit. Add a classic touch to any edge or highlight door fronts and panels with decorative layered effects.



848

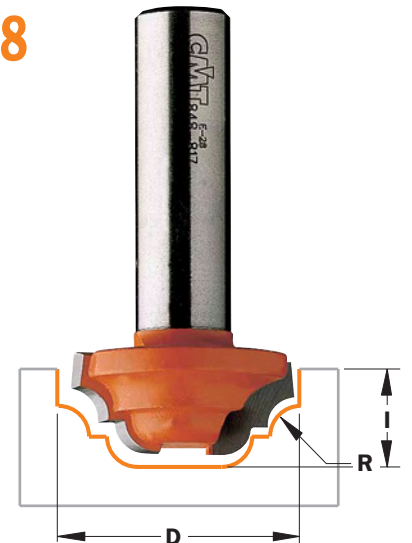
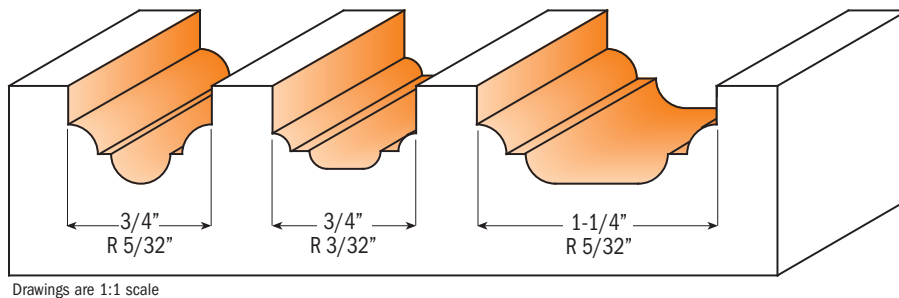

Order No. 1/4" shank	Order No. 1/2" shank	D_Cutting diameter inches	R_Cutting radius mm	I_Cutting length inches
848.190.11		3/4	19	5/32
848.191.11		3/4	19	3/32
	848.817.11	1-1/4	31.7	5/32

848B



You will never run out of clever, creative applications for this bit. Add a classic touch to any edge or highlight door fronts and panels with decorative layered effects.

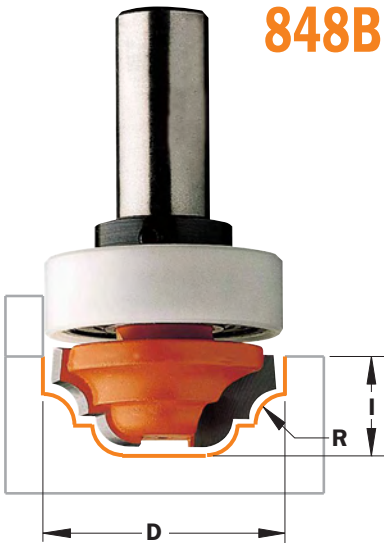

Order No. 1/4" shank	Order No. 1/2" shank	D_Cutting diameter inches	mm	R_Cutting radius inches	I_Cutting length inches	B_Bearing diam. inches
848.190.11B		3/4	19	5/32	1/2	3/4
848.191.11B		3/4	19	3/32	7/16	3/4
	848.817.11B	1-1/4	31.7	5/32	1/2	1-1/4
spare parts:						
791.004.00	3/4" bearing					
791.015.00	1-1/4" bearing					
541.001.00	Stop collar for 1/4" shank					
541.002.00	Stop collar for 1/2" shank					
991.056.00	1.5mm allen key for stop collars					

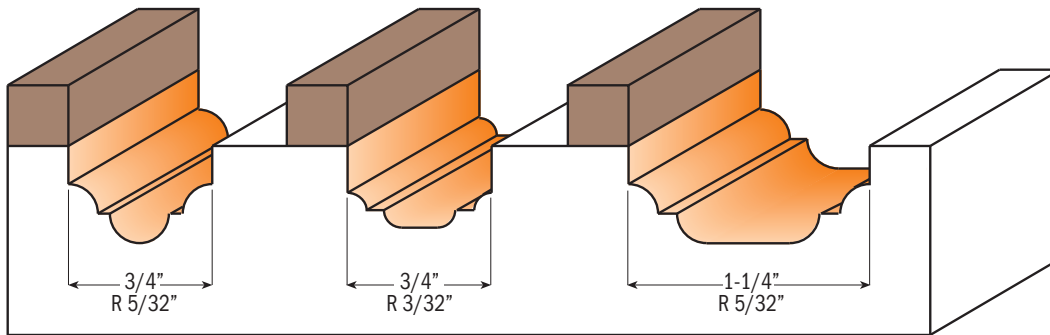

Drawings are 1:1 scale

Decorative Beading Bits

865



These new bits are great for a wide variety of decorative veining and edgework tasks. All are carbide-tipped to ensure a clean, sharp cut. Both families of profiles are offered with an optional top bearing for pattern work.

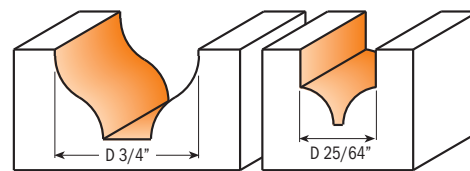
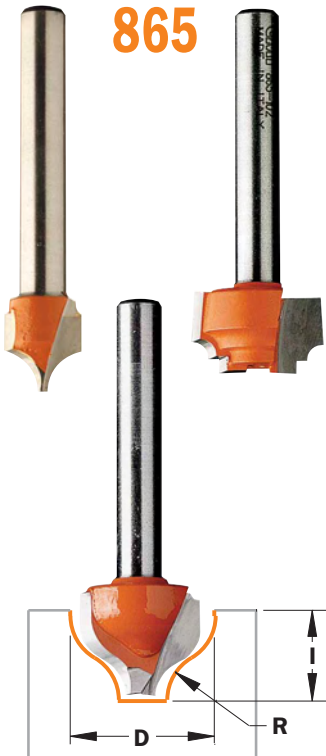

865.001.11
865.501.11

865.402.11

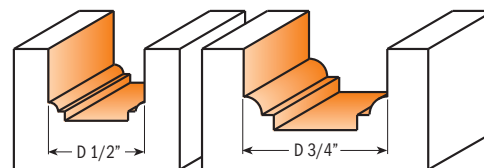

865.101.11

865.102.11

Drawings are 1:1 scale

Order No. 1/4" shank	Order No. 1/2" shank	D_Cutting diameter inches	mm	R_Cutting radius inches	I_Cutting length inches
865.001.11	865.501.11	3/4	19	1/4	7/16
865.101.11		1/2	12.7	3/64	1/2
865.102.11		3/4	19	3/32	7/16
865.402.11			10	13/64	25/64

CMT's new classic panel ogee with ball bearing guide gives you even more decorative possibilities for panel and edge work. The bit design gives you a wide flat bottom cut and the longer shank allows for deeper detailing.



865B

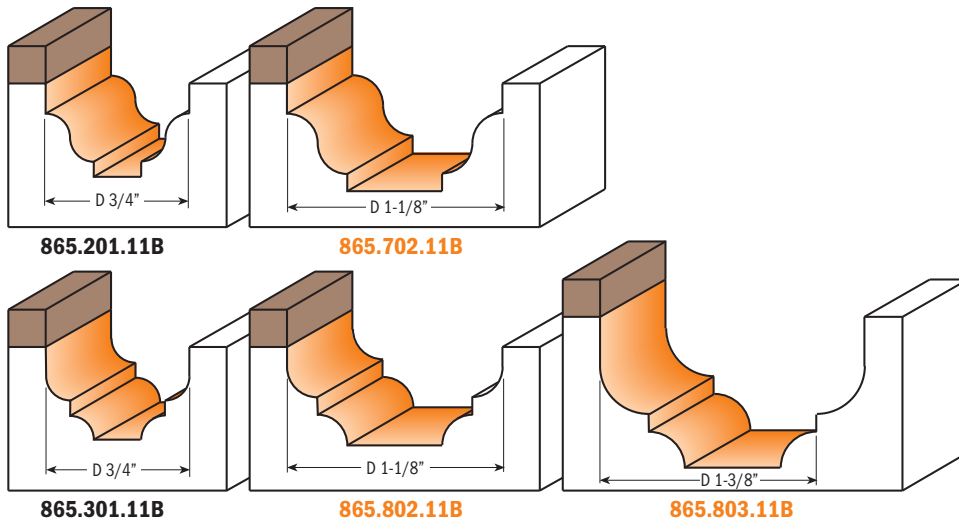

Drawings are 1:1 scale

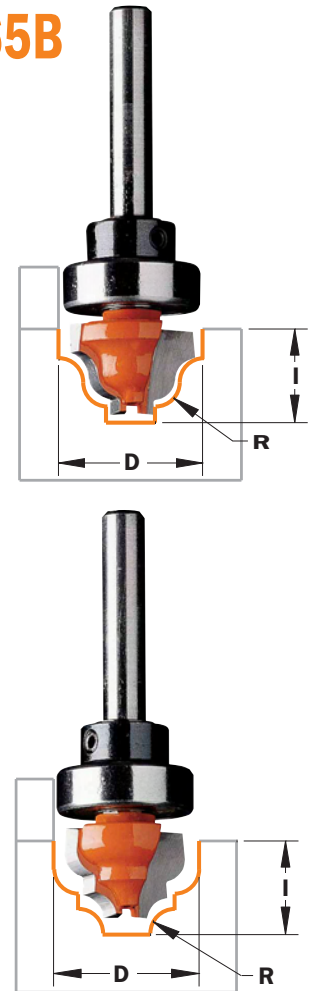

Order No. 1/4" shank	Order No. 1/2" shank	D_Cutting diameter inches	mm	R_Cutting radius inches	I_Cutting length inches
865.201.11B		3/4	19	1/8	31/64
	865.702.11B	1-1/8	28.6	5/32	9/16
865.301.11B		3/4	19	1/8	31/64
	865.802.11B	1-1/8	28.6	5/32	1/2
	865.803.11B	1-3/8	34.9	1/4	23/32

spare parts: 791.004.00 3/4" bearing 541.002.00 Stop collar for 1/2" shank
 791.027.00 1-1/8" bearing 991.056.00 1.5mm allen key for stop collars
 541.001.00 Stop collar for 1/4" shank

Flute & Bead Sets

Build your own cedar strip canoe, hot tub, or lots of other curved shapes with this perfectly matched CMT set. Durable carbide tips stay sharp even after cutting great quantities of stock, and the anti-kickback design helps to ensure your safety when routing. For fluting and beading 1/4" slats for a curved glue-up as shown below, use both the flute and the bead bits in the set.



855.701

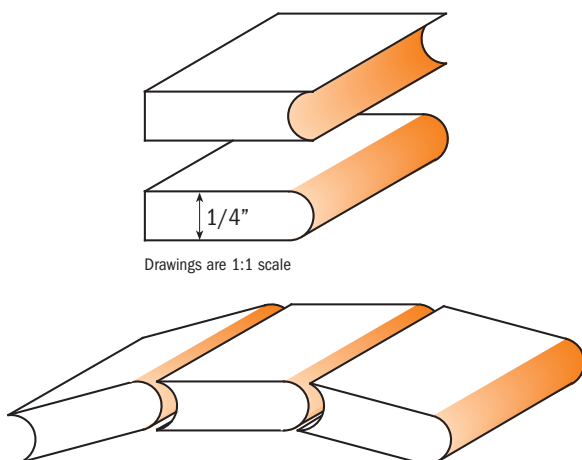

Drawings are 1:1 scale

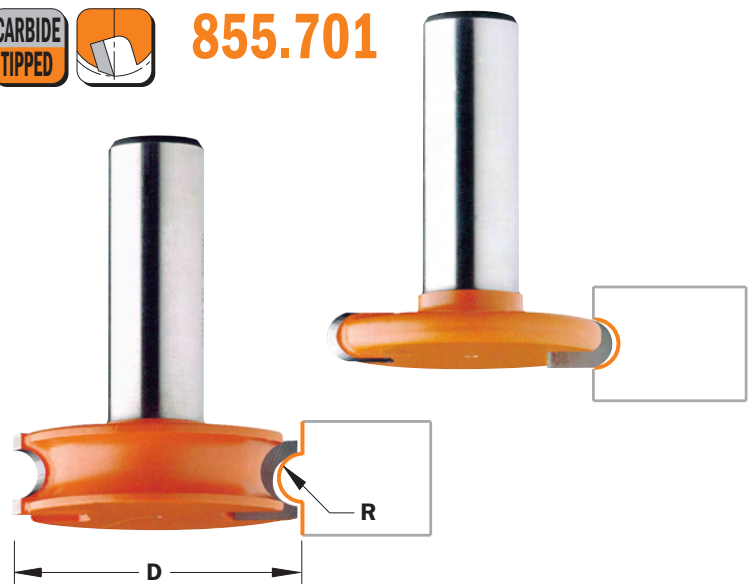

Order No. 1/2" shank	R_Cutting radius inches	mm	D_Cutting diameter inches
855.701.11	1/8	3.2	1-1/2

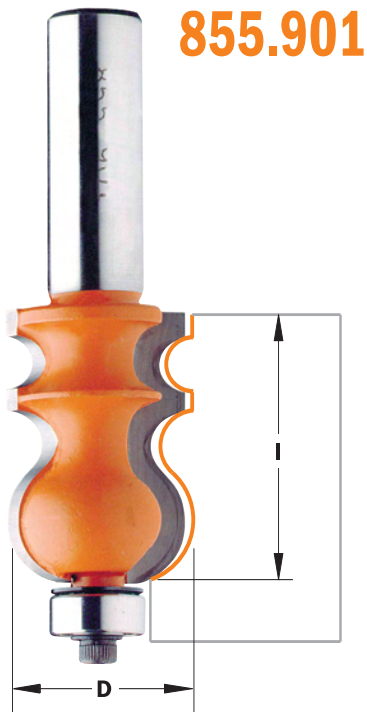

855.901



CMT Molding Bits allow you to create a wide range of molding and millwork designs, especially when they are used for a sequence of two or more passes. For even more options, use the Classical and Traditional bits on the following pages in conjunction with the Molding Bit.

These CMT Bits are made to last a lifetime, with carbide tipped cutters and solid bar stock steel shanks that withstand serious use. Plus, CMT's baked-on non-stick PTFE coating helps keep bits clean for smooth cuts.

Our anti-kickback feature helps guarantee you work more safely when using these large profile bits.

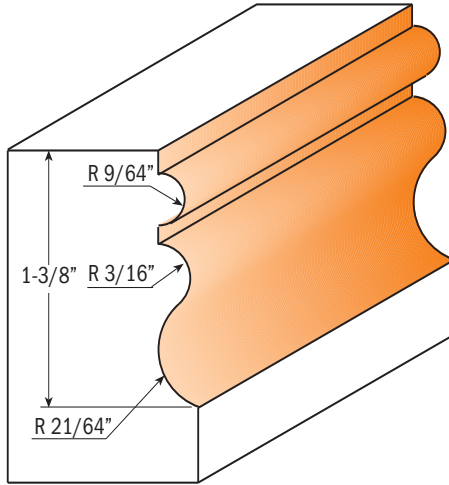

Drawings are 1:1 scale

Order No. 1/2" shank	D_Cutting diameter inches	I_Cutting length mm	B_Bearing diam. inches
855.901.11	15/16	23.8	1-3/8
spare parts:			
990.423.00	1/2" shield		
791.003.00	1/2" bearing		
990.058.00	Screw for bearing, 1/8W x 3/8"		
991.057.00	3/32" hex key for 1/8W screws		

Traditional Bits

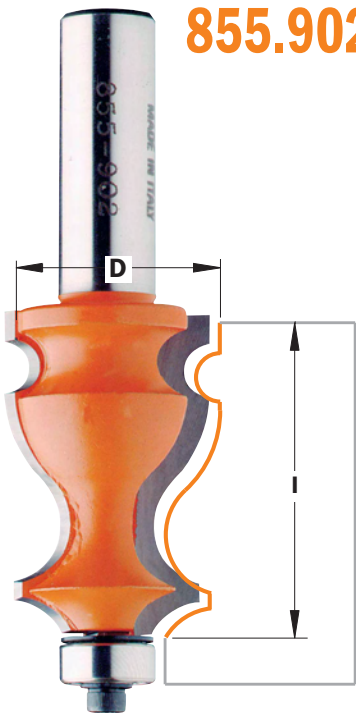

855.902



The Traditional Bit is one of CMT's most versatile designs. Use the full profile to create unique molding, or use just a portion of the cutting edge to create the effect you need: beads, veins, coves and more.

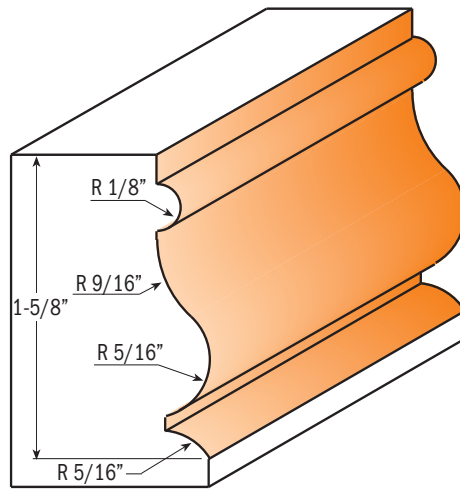

Drawings are 1:1 scale

Order No. 1/2" shank	D_Cutting diameter inches	I_Cutting length mm	B_Bearing diam. inches
855.902.11	1-1/16	27	1-5/8
spare parts:			
990.423.00	1/2" shield		
791.003.00	1/2" bearing		
990.058.00	Screw for bearing, 1/8W x 3/8"		
991.057.00	3/32" hex key for 1/8W screws		

CMT's Classical Bit combines some of the most useful shapes in routing: ogee, bead and cove. Plan your cut sequence carefully and produce intricate shapes.



856.501

Safety Precautions:

Multiple pass operations require advance planning. Carefully consider the entire cutting sequence before you begin. All large diameter bits should be used with caution and on router tables equipped with a fence. When possible, reduce the RPM of the router for operations requiring the use of these bits.

Order No.	D_Cutting diameter	I_Cutting length	B_Bearing diam.
1/2" shank	inches mm	inches	inches
856.501.11	1-7/8 47.6	1-1/8	1/2
spare parts:			
990.423.00	1/2" shield		
791.003.00	1/2" bearing		
990.058.00	Screw for bearing, 1/8W x 3/8"		
991.057.00	3/32" hex key for 1/8W screws		

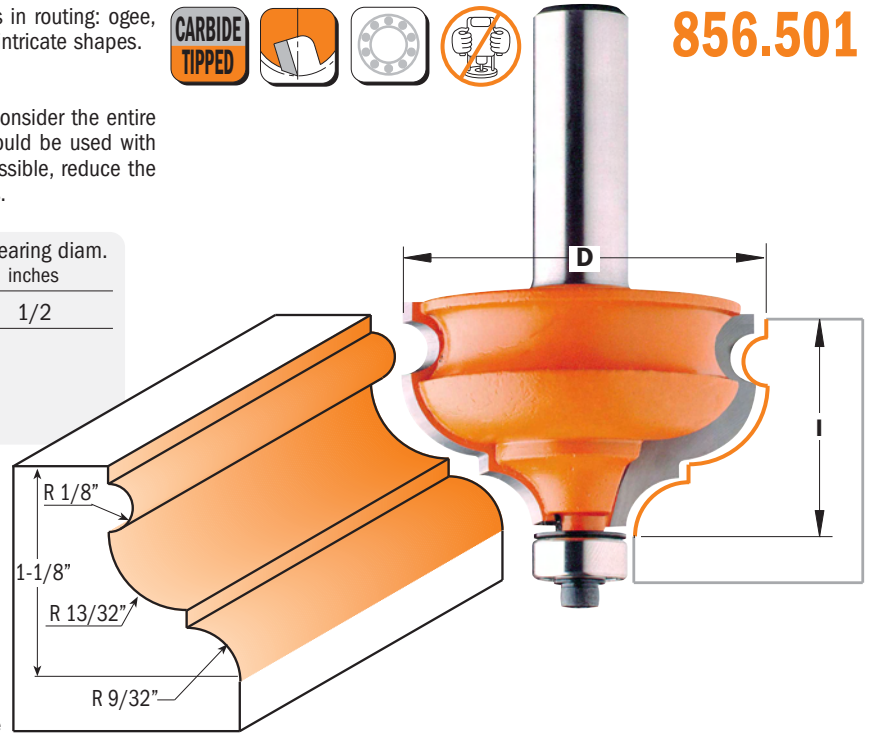

Drawings are 1:1 scale

Table Edge & Hand Rail Bits

Either of these bits will be a great addition to your shop, or buy them both to build a beautiful hand rail.



856.601/701

Table Edge Bit: Our table edge bits give perfectly smooth well-proportioned curves to dining and coffee table edges. It's a beautiful shape that also provides a comfortable place to lean after dinner.

Hand Rail Bit: with a 30° bevel edge and a 1/8" bead, these bits make beautiful and functional hand rails that add an understated touch of class to any architectural setting.

Safety Precautions:

These bits create a great quantity of saw dust. We suggest using a vacuum on your router table to make the job easier and keep the work area safe.

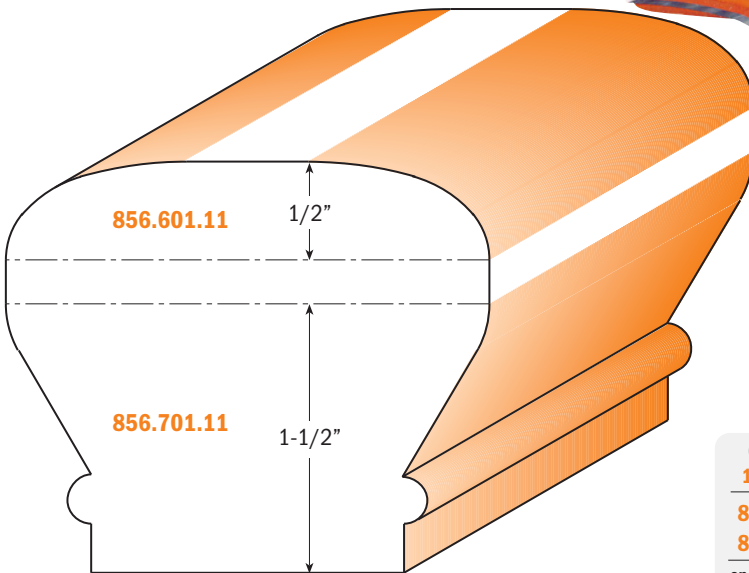

Drawings are 1:1 scale

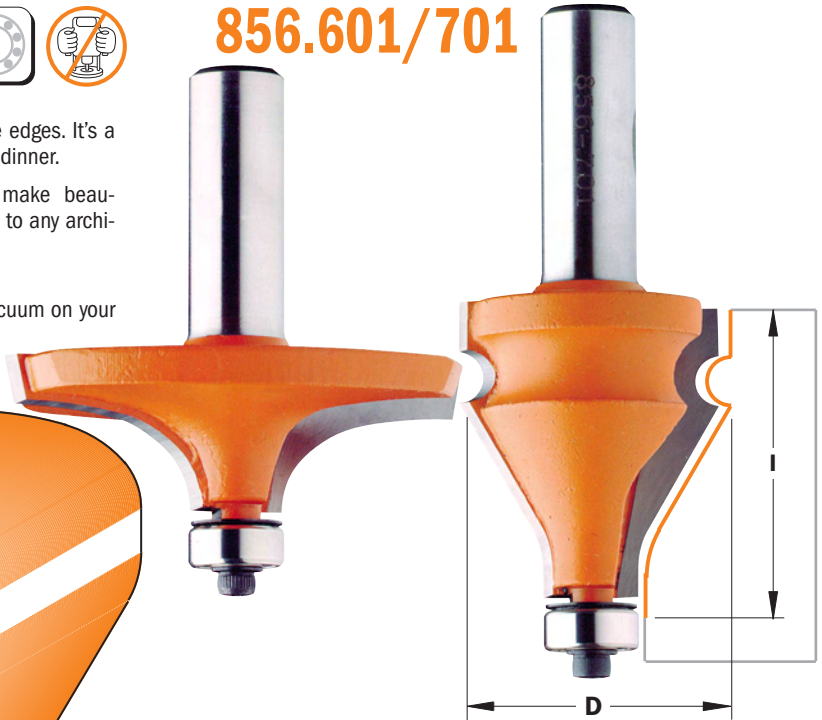

Order No.	D_Cutting diameter	I_Cutting length	B_Bearing diam.
1/2" shank	inches mm	inches	inches
856.601.11	2-1/2 63.5	3/4	1/2
856.701.11	1-3/8 35	1-1/2	1/2
spare parts:			
990.423.00	1/2" shield	990.058.00	Screw for bearing, 1/8W x 3/8"
791.003.00	1/2" bearing	991.057.00	3/32" hex key for 1/8W screws

856.851

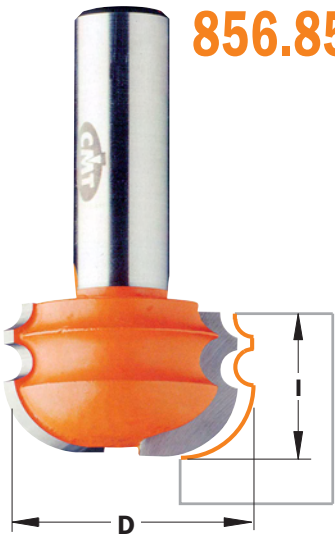

CARBIDE TIPPED



856.852



If the standard selection of molding and mill work in today's lumber yard just doesn't fill the bill, then look to CMT's molding system instead. With these bits you can make dozens of elaborate profiles by combining two or more passes. Avoid the average and create your own moldings.

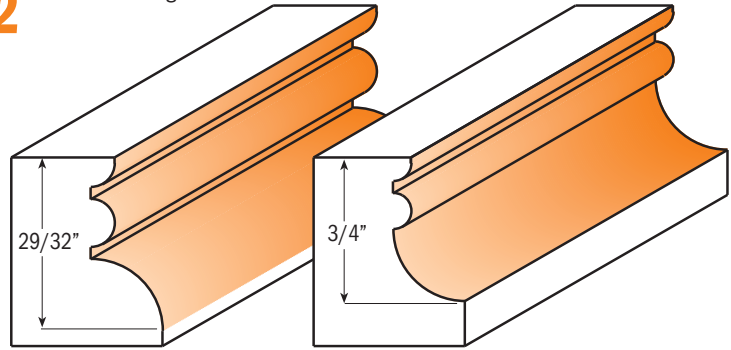

856.852.11

856.851.11

Drawings are 1:1 scale

Order No. 1/2" shank	D_Cutting diameter inches	mm	I_Cutting length inches
856.852.11	1-1/4	31.7	29/32
856.851.11	1-1/4	31.7	3/4

Multiprofile Bits

856.801 856.802

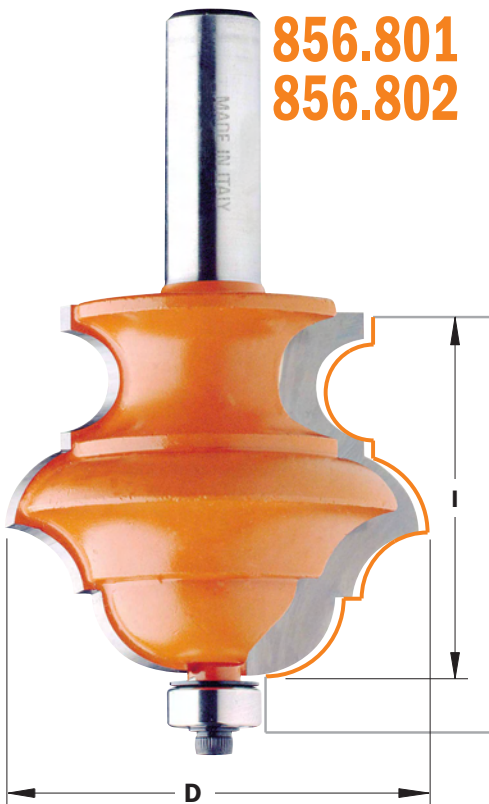

CARBIDE TIPPED



When we named this the Multiprofile Bit, we weren't kidding. In fact, there's almost no limit to the number of shapes you can rout with this tool. Adjust the height of the bit or the position of the router table fence to create classic profiles in a single pass. Or make several passes to create more complex and decorative effects. The super-strength steel body of the CMT multiprofile bit stands up to hours of cutting, and the micrograin carbide tips stay sharp longer for a guaranteed superior performance. Features baked-on non-stick PTFE coating and anti-kickback design. Use on tables equipped with a fence.

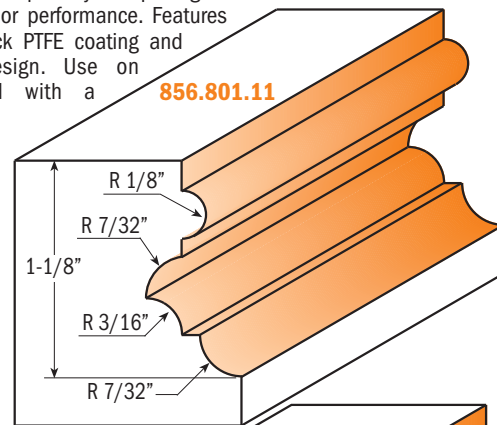

856.801.11

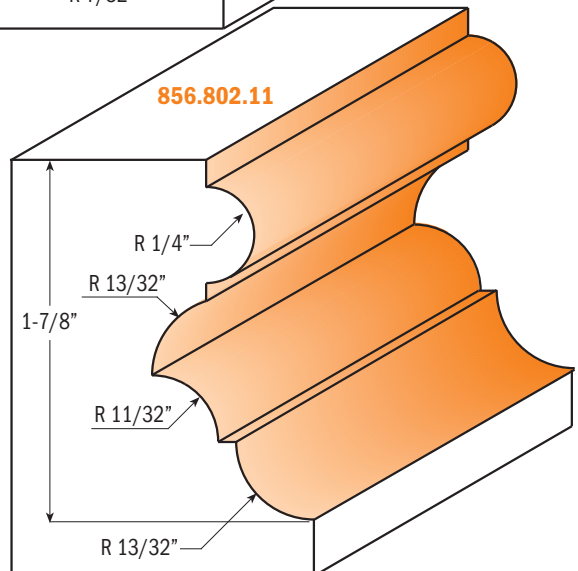

856.802.11

Order No. 1/2" shank	D_Cutting diameter inches	mm	I_Cutting length inches
856.802.11	2-3/16	55.6	1-7/8
856.801.11	1-1/2	38.1	1-1/8
spare parts:	990.423.00	1/2" shield	
	791.003.00	1/2" bearing	
	990.058.00	Screw for bearing, 1/8W x 3/8"	
	991.057.00	3/32" hex key for 1/8W screws	

Drawings are 1:1 scale

Reverse Glue Joint Bit

CMT's Reverse Glue Joint Bit produces an almost indestructible glue joint quickly and accurately. Ideal for joining wide panels, doors and furniture parts. By accurately centering the bit in the wood, the upper and lower vertical cutting edges of the bit will cut equal proportions. Simply run one edge of the panel, turn the panel over, and then run the opposite edge - you will produce perfectly matched reverse cuts that form flawless joints.



855.501

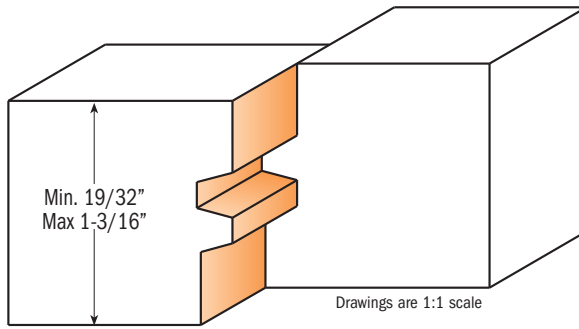

Tip: When gluing, apply enough pressure to securely seal the joint. Insufficient pressure results in a weak joint and excessive pressure will distort the wood.

Order No.	D_Cutting diameter	I_Cutting length	T_Joint thickness
1/2" shank	inches mm	inches	inches
855.501.11	1-3/4 44.4	1-1/4	19/32 - 1-3/16

In this example we have used a 3/4" board

For accurate cuts, the bit must be centered on the edge of the workpiece. When the bit is properly centered, the upper and lower vertical "shoulders" will be the same height. Line up the center of the edge of the workpiece with the center point of the bit as shown in the enlarged drawing. Make test cuts and adjust the bit height as needed before cutting your workpiece. Once the bit's height is properly set, make the cut on one piece of stock with the face side up, then make the cut on the matching piece with the face side down.

Drawer Lock Bits

Most drawers live a pretty tough life. They're pulled and pushed and usually overloaded, so the key to success when constructing fine drawers is in the quality of the joint you choose for the corners. With CMT Drawer Lock Bits you can make strong, perfectly fitting joints quickly and easily. Be sure to keep the setup illustrations below close by when you build your first joint.



855.502
855.002

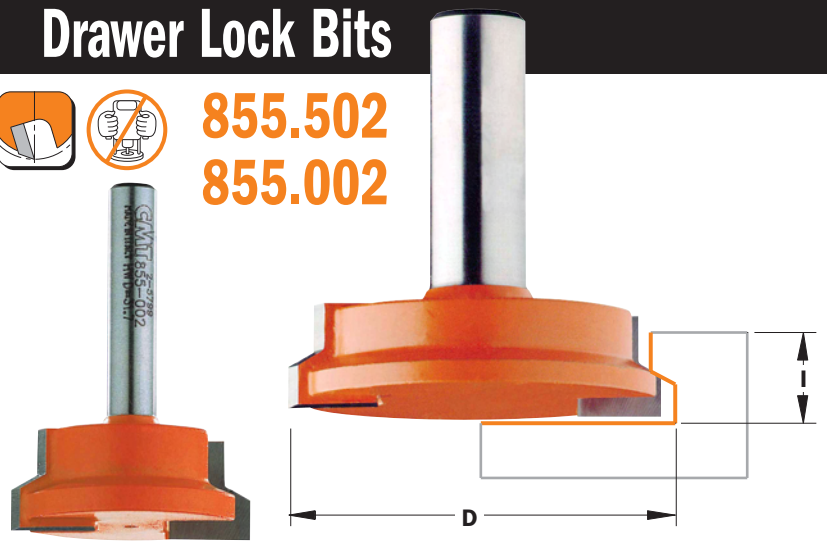
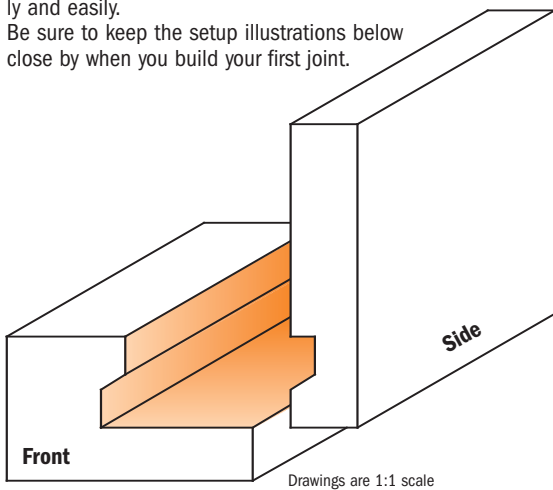

Order No.	Order No.	D_Cutting diameter	I_Cutting length
1/4" shank	1/2" shank	inches mm	inches
855.002.11		1-1/4 31.7	1/2
	855.008.11	1 25.4	1/2
	855.502.11	2 50.8	1/2

As illustrated, mill the drawer front with the inside face down on the router table. Mill the sides of the drawer with the inside face of the workpiece placed vertical in relation to the bit and fence, and perpendicular to the table. Make a few test cuts on scrap stock to test your setup. These bits are to be used on router tables only and are not to be used on hand held routers.

855.601

CARBIDE
TIPPED



Mill a beautiful, perfectly-shaped wooden handle that harmonizes with your doors and drawers with the CMT Finger Pull Bit. Choose the pull style that suits your door: a template profile routed in the wooden door, or a European-style hardwood pull as illustrated. Please take the time to study the instructions before using the bit, and be sure to make test cuts on scrap material.

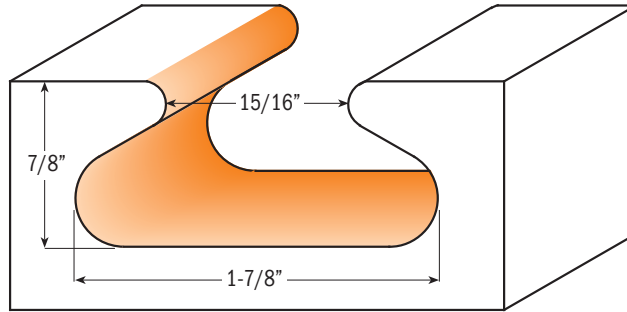
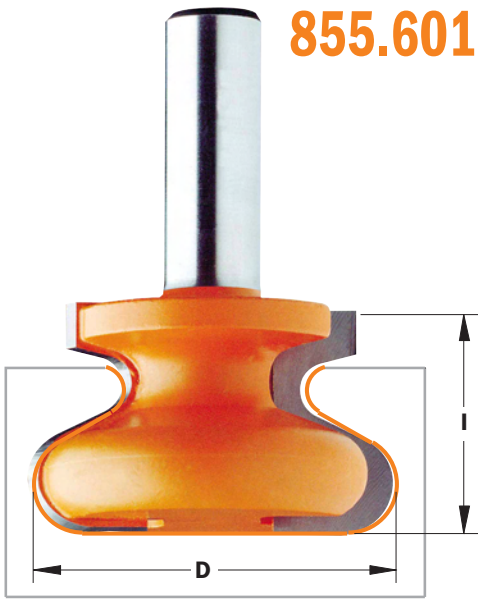

Drawings are 1:1 scale

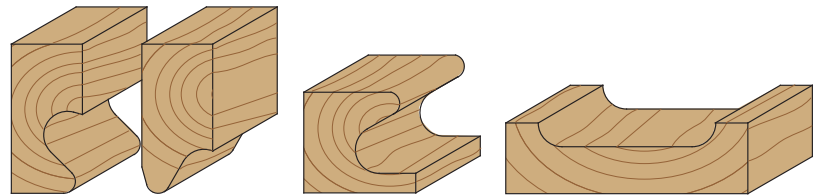

Order No.	D_Cutting diameter		I_Cutting length
1/2" shank	inches	mm	inches
855.601.11	1-7/8	47.6	1-1/8

Milling European Style Pull

For our example we used:

CMT Finger Pull Bit (item 855.601.11) - CMT Slot Cutter (item 822.360.11) - 1-9/16" hardwood stock

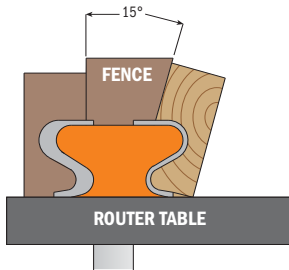

STEP 1: Install the Finger Pull Bit in your router and router table. Set up the fence at 15° in relation to the bit, as illustrated at right. Mill the stock using push blocks, being careful not to over feed. This cut removes large amounts of stock, so always use extra caution.

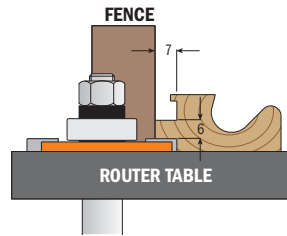

STEP 4: Keeping the fence in the 9/32" position, lower the bit to groove a 15/64" tongue, as shown.

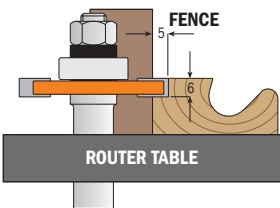

STEP 2: Put the 15/64" CMT Slot Cutter in the router table and align the bit with the top face of the milled handle pull piece. Adjust the fence to make a 13/64"-deep groove as shown in the illustration. This is the initial cut to form the lip that will be visible on the face of the door.

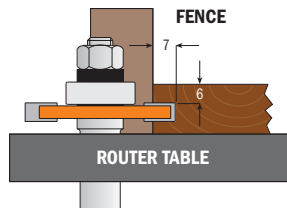

STEP 5: To rout the groove for the tongue in the edge of the door, keep the fence in the 9/32" position. Set the slot cutter 15/64" down from the front face of the door and rout the groove as shown in the illustration.

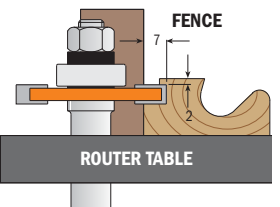

STEP 3: Lower the bit 5/64" and adjust the fence to mill a 9/32"-deep groove. This forms the lip that overlaps the cut edge of the front face of the door, making the finger pull joint extra secure and more attractive.



STEP 6: Assemble the joint for a beautiful European style hand pull door!

855.801

Create wooden windows that are as beautiful as they are functional with your CMT Window Sash Set. As a bonus, this set will also mill perfectly matched 1-3/8" rail and stile parts for custom made interior doors. Like all CMT bits, these tools include our anti-kickback design, trademark non-stick orange coating, high strength steel and micrograin carbide cutting edges for longer life. The set includes two bits for cutting the male and female parts. Suitable for stock up to 1-3/8" thick, not for use in hand-held routers.

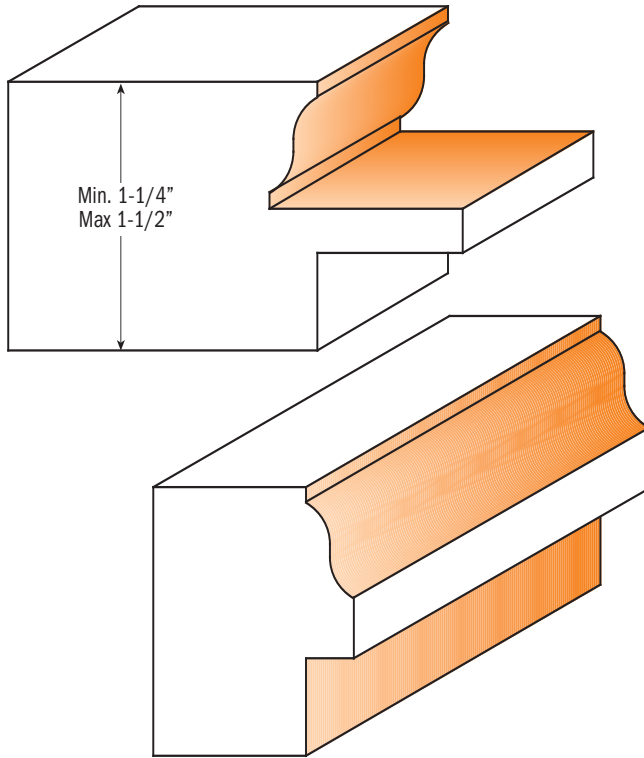

Drawings are 1:1 scale

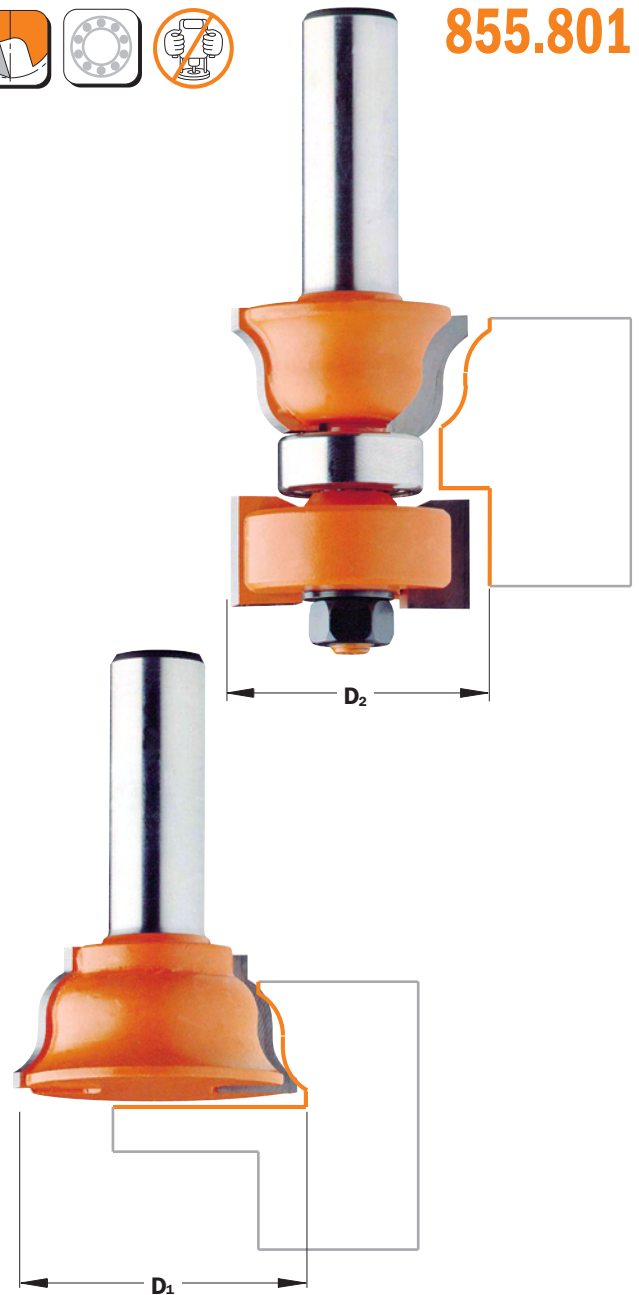

Order No.	D ₁ Cutting diameter		D ₂ Cutting diameter		B Bearing diameter
	inches	mm	inches	mm	mm
1/2" shank					
855.801.11	1-3/8	35	1-1/2	38	22
spare parts:	791.012.00	22mm shield	541.018.00	1mm spacer	
	822.004.11	Two-flute slot cutter	990.020.00	Nut, M8 thread	

Step by Step Instruction available on the web!

In this step by step example for window sash construction, we used the following:

- CMT Window Sash Set (Item No. 855.801.11)
- stile cut 1-3/8" thick
- rail cut 1-3/8" thick
- scrap stock

The CMT Window Sash Set was designed ideally for the construction of windows in 1-3/8" stock, however, variations as narrow as 1-7/64" can be used. Stock thicker than 1-3/8" exceeds the milling range of the cutter. Remember to adjust your measurements and cutting depths according to the wood thickness you use. We suggest making a trial joint in scrap stock according to the following steps before milling all of the cope and stick profiles.

STEP 1

Cut your stiles, rails, sash bars, and muntins to the width and length from 1-3/8" thick stock. Here's how to calculate the lengths of your parts, using an 18x24 window with 3" wide rails and stiles as an example.

First, cut the stiles to the full height of the window (24"). To figure rail length, subtract the combined width of the stiles (6") from the finished width of the window (18"). To this number (12"), add the length of two tenons (1-1/4" + 1-1/4") and 1/2" (for the coped joint). So, for our example we cut the rails 15" long. Cut the sash bars and muntins 3/4" wide and calculate their lengths as you did the rails. (Plan to cut 1-1/4" long tenons on both ends of the sash bar and muntins; you'll trim the muntin tenons that intersect with the sash bars to 1/8" long later.)

STEP 2

Mark the face side of your workpieces (the inside surface of your window or the most-viewed side of your door). Also, mark the outside edges of the rails and stiles, and place marks centered on the rails and stiles where they intersect with the muntins and sash bar, and on the sash bar where it intersects with the muntins.

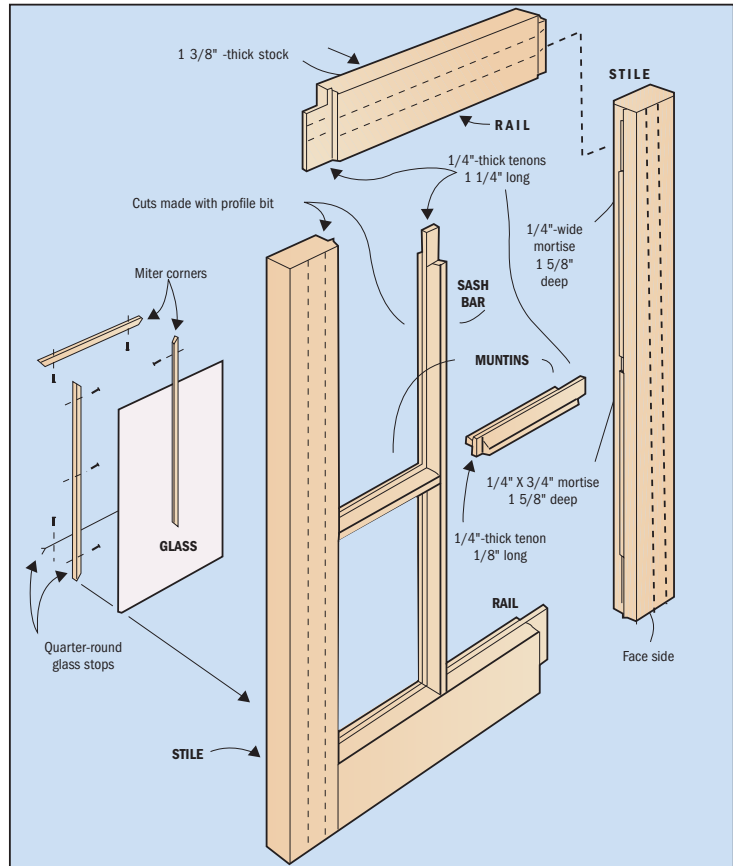
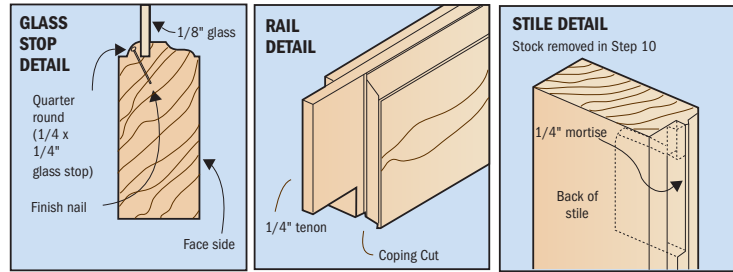
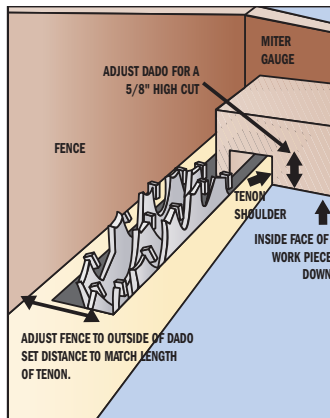

STEP 3

To cut 1-1/4" tenons on both ends of the rails, sash bars, and muntins, install a full-width dado set in your tablesaw and adjust it for a 5/8" high cut. Position the saw's fence 1-1/4" from the side of the dado set farthest from the fence. Place the workpiece on the tablesaw face down with one edge against a miter gauge, and one end against the fence. Make the cut in multiple passes .

STEP 4

Position the rail, sash bar, or muntin face side up on the tablesaw. Place a 1/8" spacer between the workpiece and tablesaw top and make the same cut as described in the previous step. Your tenons should be 1/4" thick.

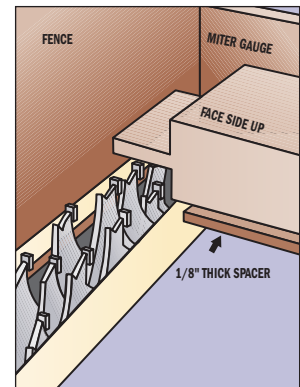

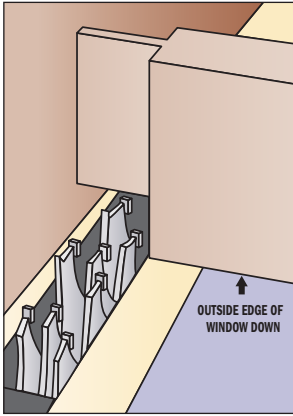

STEP 5

Complete the tenon cuts on the rails by placing them outside edge down on the tablesaw. Make multiple cuts with the dado set 5/8" high as before.

Install the coping bit in your router table. Place the face side of the rail on the table and adjust the coping bit up so the tops of its cutters contact the tenon. With the fence adjusted so the coping bit cuts 1/4" past the tenon shoulder, cut both ends of the rails, sash bar, and muntins. (For a 1-1/4" long tenon, set the fence 1-1/2" from the cutter tip with the tip rotated to its farthest distance from the fence.)

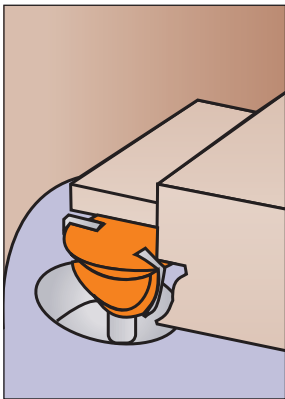

STEP 7

Mark the positions of the mortises on the stiles by using the tenon that mates with it. First, stand the stile inside edge up on a work surface and position the rail to mark the length of the mortise. Then, rest the rail on top of the stile to mark the mortise width. Use the same steps to mark the position of the mortises that hold the sash bar and muntin tenons.

Cut the mortises 3/8" deeper than the length of the tenons. The mortise in the sash bar will go completely through it.

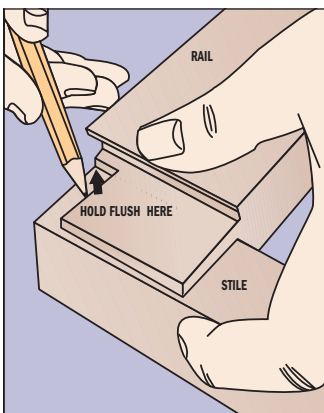

STEP 8

Install the profile bit in your router table and adjust it. With the face side down, mold the inside edges of the rails and stiles.

STEP 9

To perform the same operation on the sash bar and muntins, clamp a secondary fence onto the router table. Make this fence from 1-1/4" thick stock,

and position it so the sash bar and muntins slide snugly between it and the main fence.

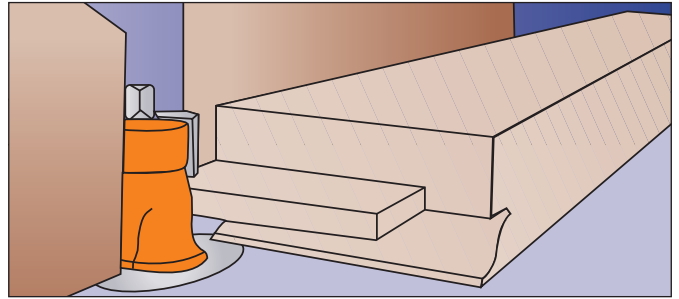

STEP 10

Mold both edges of the sash bar and muntins. Use pushsticks to pass the stock between the fences.

Use a fine-toothed saw to remove the small amount of material on the outside end of each stile mortise and in the Stile Detail drawing on page 12. If you make more than one window or door you may want to set up a router table with a straight bit to do this more quickly.

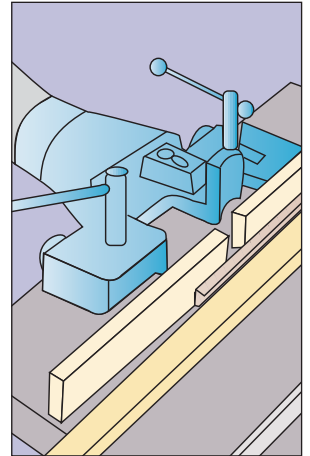

Now's a good time to trim the muntin tenons that intersect the sash bar. Cut them to 1/8" long.

STEP 11

Assemble the project without glue to check it for fit and squareness. Disassemble, apply glue to all mating surfaces and clamp. Check for square again before the glue sets up.

STEP 12

Install the glass in the rabbeted openings on the back face of the door or window. Each pane should be 1/8" smaller in width and length than the rabbeted opening it fits into. Mount the glass in place with glazing points and glazing putty, or with quarter-round strips of wood mitered on their ends and nailed down.

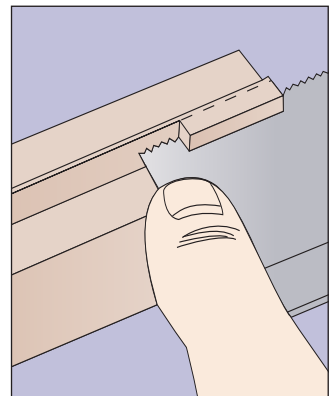

Window Sash instructions courtesy of Wood Magazine
For Subscriptions-call 1-800-374-9663 or visit Wood online at www.woodmagazine.com



The lock miter joint is perfect for a long list of right angle or parallel joints: boxes, stretcher bars, frames, edge-to-edge glue-ups and more. In fact, these bits are so popular that we now offer two sizes, allowing you to mill joints in stock as thin as 3/8" or as thick as 1-1/8".

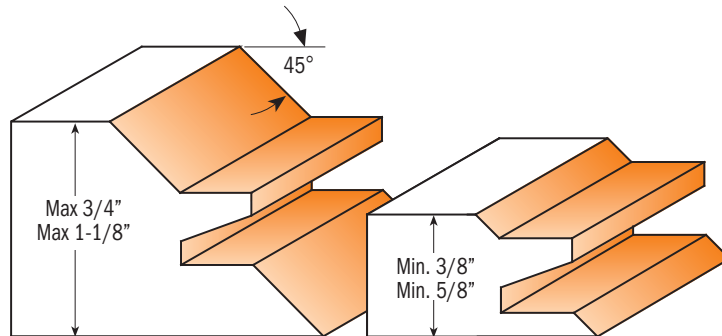

Drawings are 1:1 scale

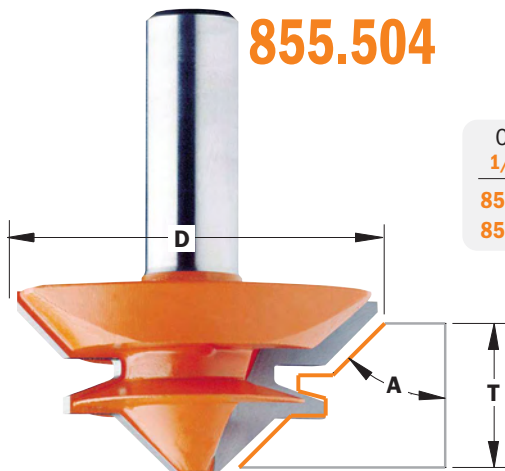

Order No. 1/2" shank	D_Cutting diameter inches	D_Cutting diameter mm	I_Cutting length inches	A_Cutting angle	T_Joint thickness inches
855.503.11	2-3/4	69.8	1-1/4	45°	5/8 - 1-1/8
855.504.11	2	50.8	7/8	45°	3/8 - 3/4

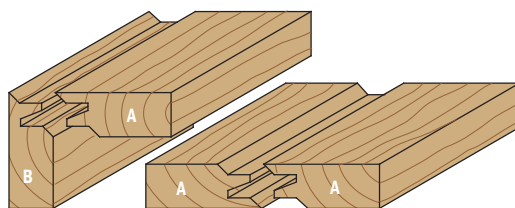

TO MILL STURDY PARALLEL GLUE JOINTS

Follow the instructions in Step 1 and Fig. 1 below for the first piece of stock, routing the joint with the inside face of the workpiece laid flat on the table and centered to the bit. To rout the second piece of stock, lay the workpiece flat on the table and centered to the bit with the inside face up.

Miter and Glue Joints with the Lock Miter Bit

Example shown below is made using Lock Miter Bit 855.503.11 and 3/4" stock.

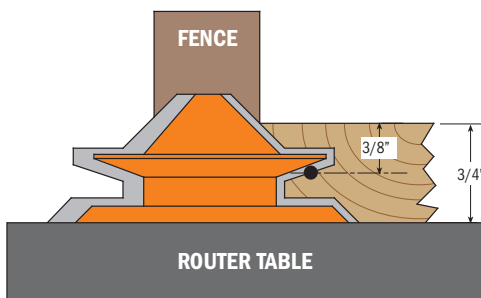

Fig. 1

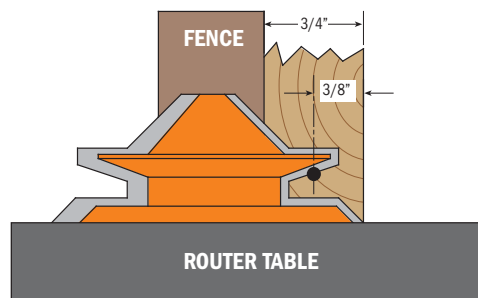

Fig. 2

TO PRODUCE PERFECTLY FITTING MITER JOINTS:

Step 1: Rout the first piece of stock with the inside face down on the work table and the wood centered to the bit. Mill as shown in Fig. 1 of the illustration. Use pusher blocks or a pusher stick to control the workpiece, and use featherboards attached to both the fence and table to hold the workpiece in position.

Step 2: Mill the second workpiece with the inside face of the stock placed against the fence and vertical in relation to the router table, as shown in Fig. 2. Use pusher blocks to move the workpiece, and use featherboards or other hold-in devices to keep the stock firmly against the fence.

Lock Miter Set

Octagonal shapes are very popular for kitchen corner cabinets, entertainment centers, kitchen islands and corner hutches, but the joints used to be difficult to cut and a nightmare to clamp. Now, CMT's new 22.5° Lock Miter Set provides a fast, accurate way to build a strong, tight 45° joint. Better still, the lock miter design makes it easy to clamp! This matched pair of cutters makes set-up easy. Height adjustment is not critical - simply adjust your fence so the top edge of the work piece intersects the angle of the bit where it meets the fence. After your joints are machined they can be glued and assembled and simply clamped by using strapping tape.



855.505

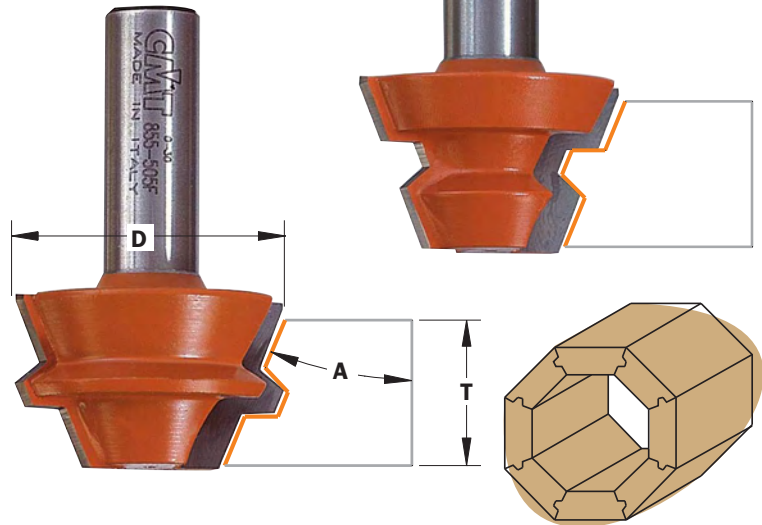
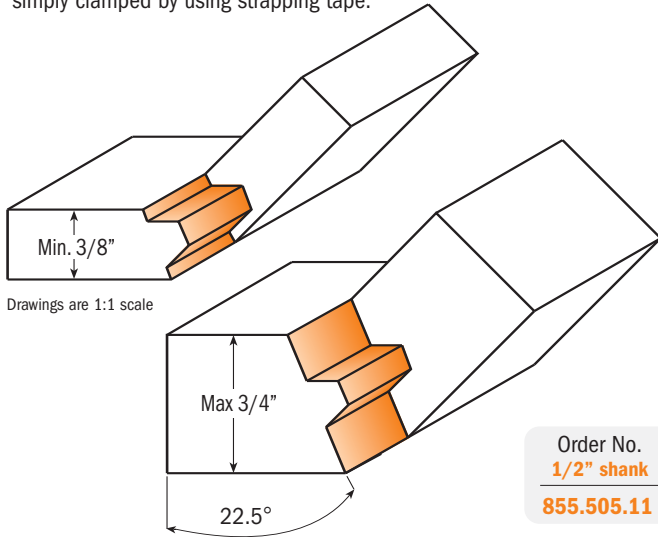

Order No.	D_Cutting diameter	I_Cutting length	A_Cutting angle	T_Joint thickness
1/2" shank	inches	mm	inches	inches
855.505.11	1-15/32	37.3	7/8	3/8 - 3/4

V-Tongue and Groove Set

This unique set from CMT will produce beautiful tongue and groove paneling or flooring with an attractive 45° "V" pattern. The difference between the CMT set and other sets is that both our bits have bearings to help guide the workpiece accurately. Our bits are carefully matched, so it's easy to change bits to make the male and female cuts. For the fastest possible production when running large volumes of stock, consider setting up on two separate router tables, with one dedicated to each cutting operation.



855.506

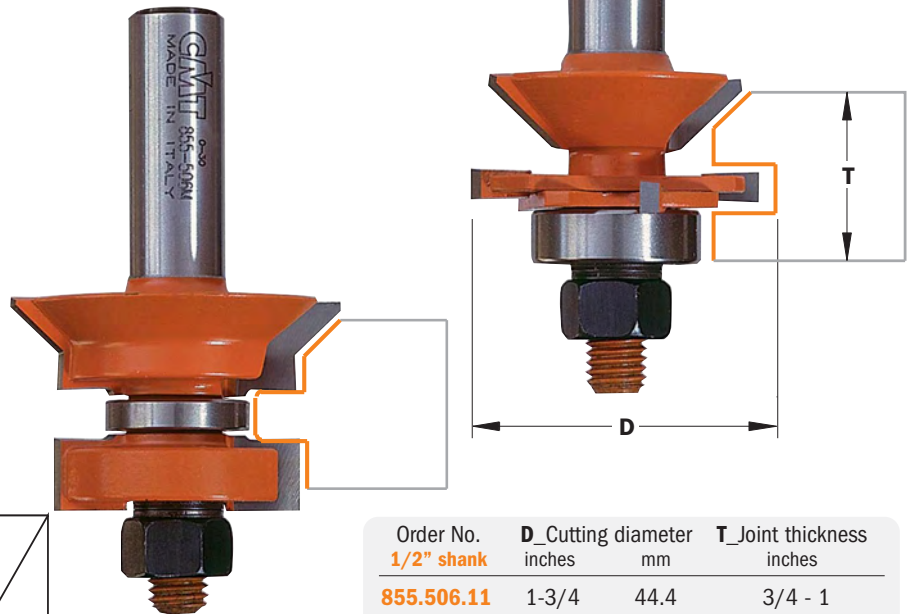
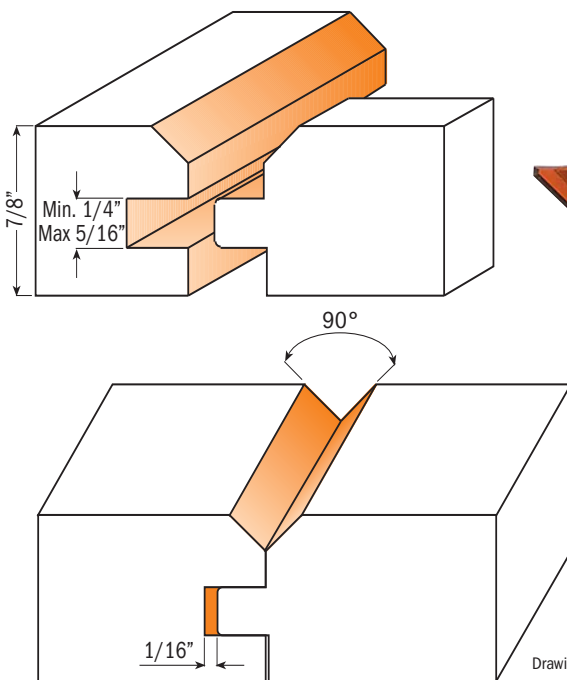

Order No.	D_Cutting diameter	T_Joint thickness
1/2" shank	inches	mm
855.506.11	1-3/4	44.4
spare parts:	822.013.11	8mm two-flute slot cutter
	822.014.11	4mm two-flute slot cutter
	791.011.00	3/4" bearing
	791.005.00	7/8" bearing
	541.515.00	0,1mm spacer
	541.516.00	0,3mm spacer
	541.517.00	0,5mm spacer
	990.020.00	Nut for arbor, M8 thread

Window Sill Bits

855.804/805



These profiles were originally intended for shaping the edges of window sills. Now these bits are also used for creating finger pulls on the edges of doors and drawers. This profile is available in a small and large version for 5/8" to 3/4" or 1" to 1-1/8" material thicknesses.

Recommended for router table use only.

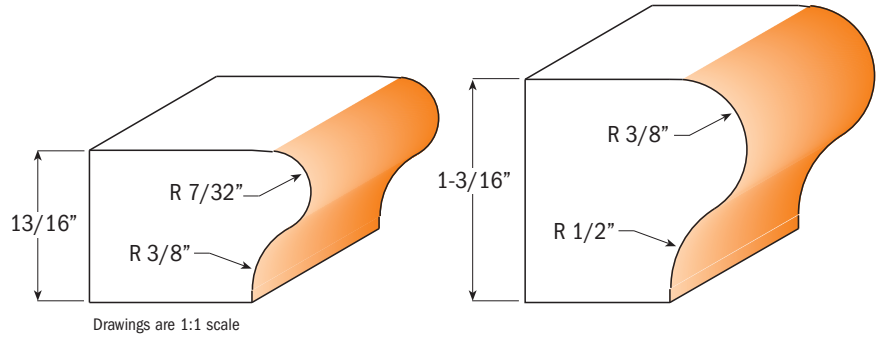
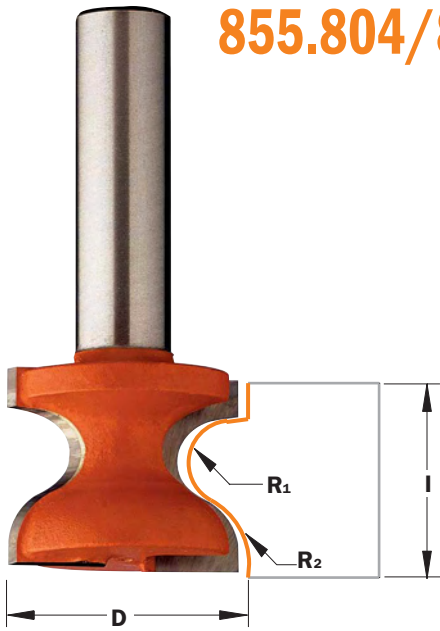

Order No.	R_Cutting radius		R_Cutting radius		D_Cutting diameter	I_Cutting length
1/2" shank	inches	mm	inches	mm	inches	inches
855.804.11	7/32	5.5	3/8	9.52	1-1/4	1
855.805.11	3/8	9.52	1/2	12.7	1-1/2	1-3/8

Window Sill Bits

855.804B/805B



A top bearing makes the Window Sill bit even more versatile. Use them to follow patterns to create curved sills, molded edges on doors or almost any part that requires an attractive edge.

Recommended for router table use only.

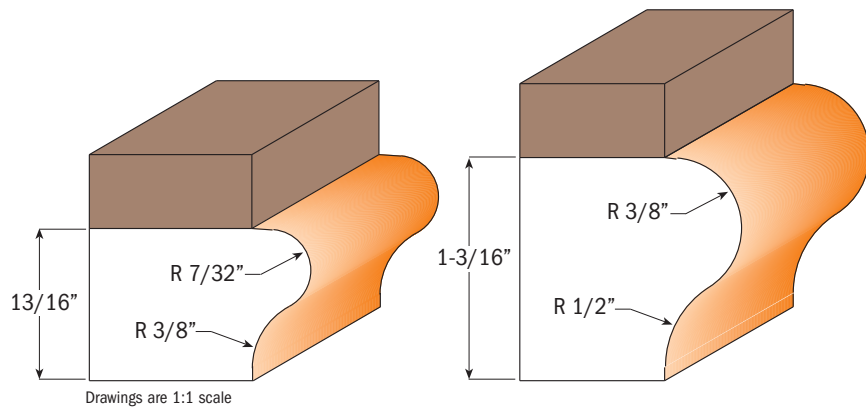
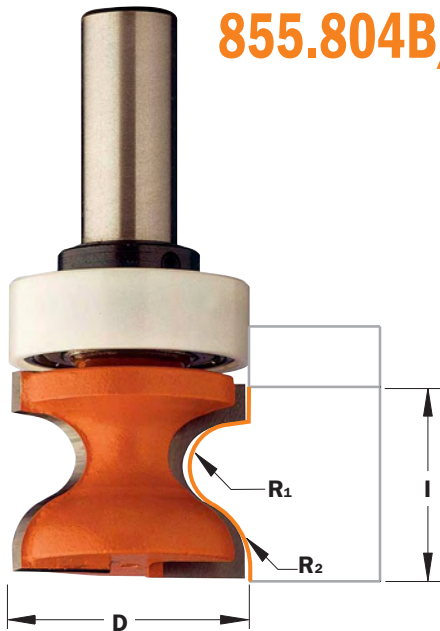

Order No.	R_Cutting radius		R_Cutting radius		D_Cutting diameter	I_Cutting length
1/2" shank	inches	mm	inches	mm	inches	inches
855.804.11B	7/32	5.5	3/8	9.52	1-1/4	1
855.805.11B	3/8	9.52	1/2	12.7	1-1/2	1-3/8

spare parts:

791.015.00	1-1/4" shield
791.020.00	1-1/2" bearing
541.002.00	Stop collar for 1/2" shanks
991.056.00	1.5mm hex key for stop collars

The versatile CMT Professional Finger Joint Bit lets you make an incredibly strong side-to-side or end-to-end joint in wood and wood composites. The tightness of the accurately cut joint and the maximum glue surface create a joint that is actually stronger than the wood itself. The bit features two flute design, carbide teeth and six removable cutters. Use different combinations of cutters to mill joints from 1/2" to 1-3/8" thick.

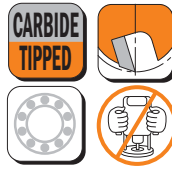

800.606

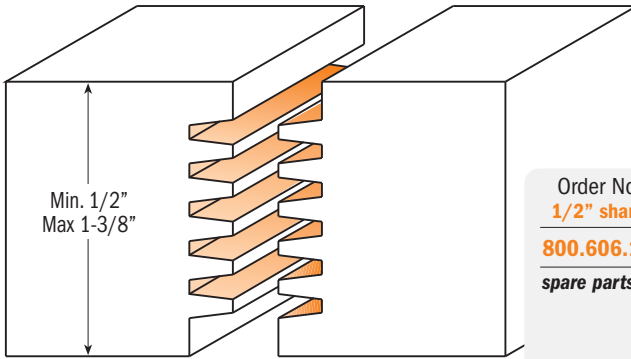
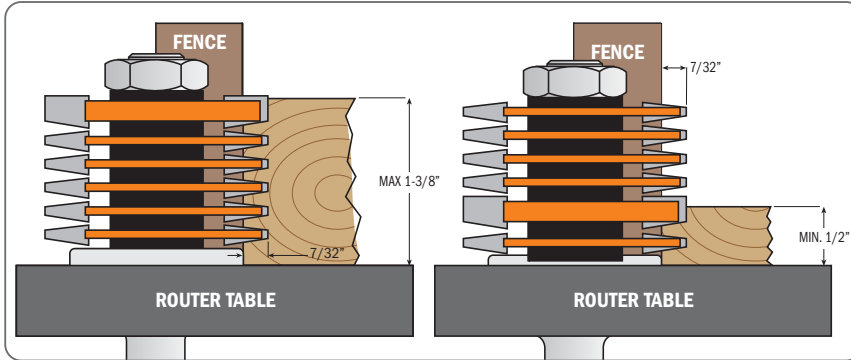

Drawings are 1:1 scale

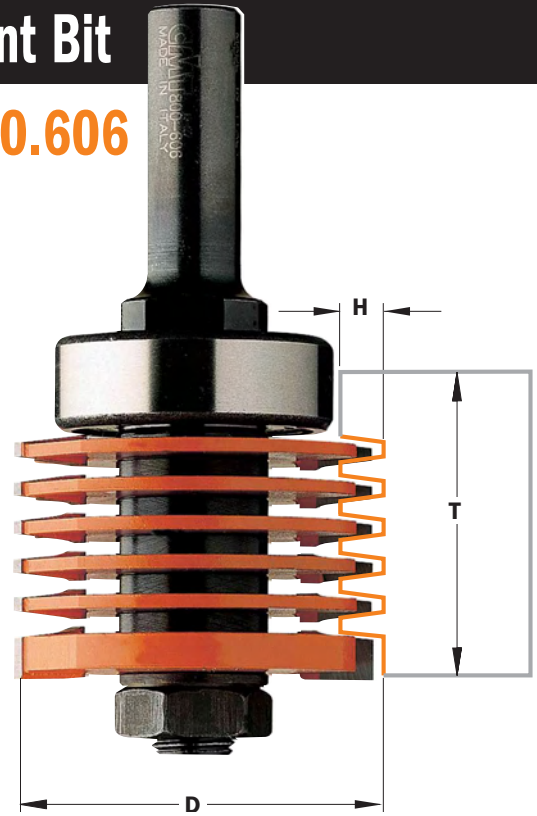

Order No.	D_Cutting diameter	H_Cutting depth	B_Bearing diam.	T_Joint thickness
1/2" shank	inches mm	inches	mm	inches
800.606.11	1-7/8 47.6	7/32	37	1/2 - 1-3/8
spare parts:	822.005.11 5/64" two-flute slot cutter	541.511.00 1/8" spacer		
	822.006.11 7/32" two-flute slot cutter	541.512.00 5/64" spacer		
	824.129.00 1/2" arbor	541.513.00 0.1mm spacer		
	791.028.00 37mm bearing	990.022.00 Nut for arbor, M12x12,5 thread		

Finger Joint Bit

This bit allows you to cut accurate and functional finger joints with ease. Simply adjusting the height of the bit allows you to cut joints in a number of different stock thicknesses, as indicated in the drawing below. The bearing cuts joints that are 3/8" deep, for other joint depths just move the fence inward.



800.616

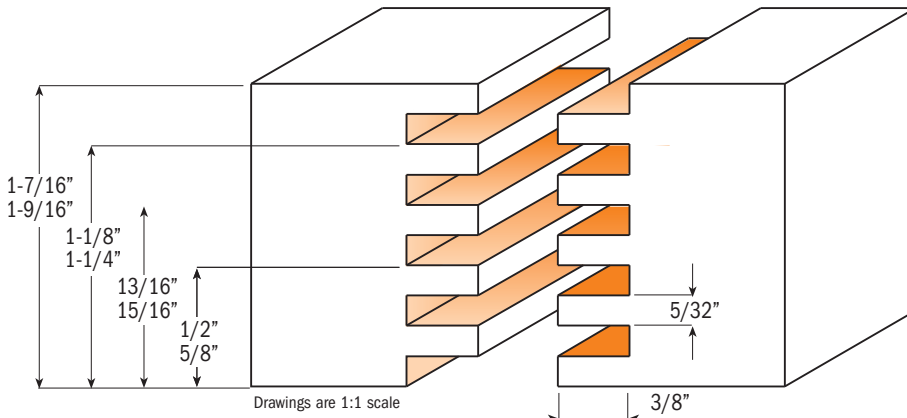

Order No.	D_Cutting diameter	H_Cutting depth	B_Bearing diam.	T_Joint thickness
1/2" shank	inches mm	inches	inches	inches
800.616.11	1-7/8 47.6	3/8	1-1/8	1/2 - 1-9/16
spare parts:	822.340.11 5/32" three-flutes slot cutter	541.515.00 0.1mm spacer		
	824.130.11 1/2" arbor	541.519.00 5.8mm spacer		
	791.027.00 1-1/8" bearing	990.020.00 Nut for arbor, M8 thread		

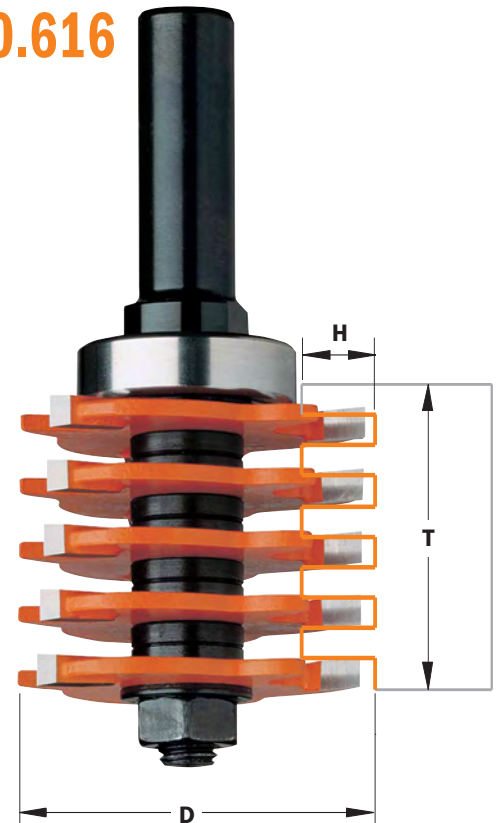

890.6



Mill raised panel doors and drawer fronts easily and economically with a CMT Vertical Raised Panel bit in your router* and a sturdy 90° fence on your router table. Choose your favorite style from three of the most popular panel profiles.

* Recommended for use on routers with a minimum speed of 2-1/4 HP. Routers as low-powered as 1-1/2 HP can be used, but we suggest limiting their use to shorter, shallower runs.

Safety Precautions:

The router table fence must be at least 6" high. Clamps and featherboards should be used when ever possible. Three to five passes are best for safety and accuracy.

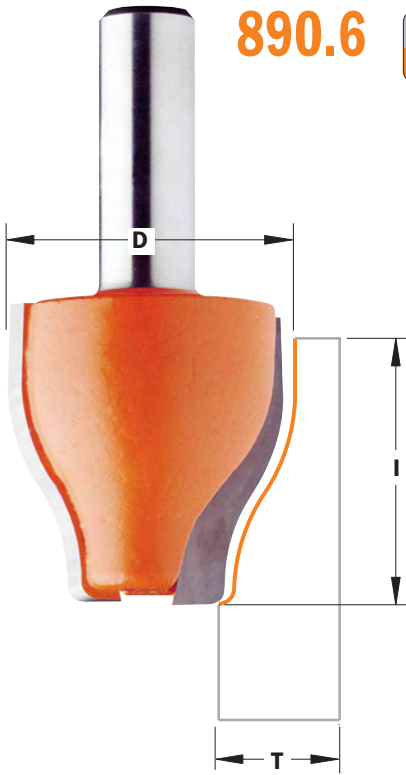

Order No. 1/2" shank	D_Cutting diameter		I_Cutting length inches	T_Joint thickness inches
	inches	mm		
890.601.11	1-1/2	38	1-1/2	19/32 - 23/32
890.602.11	1-1/2	38	1-1/2	19/32 - 23/32
890.603.11	1-1/2	38	1-1/2	19/32 - 23/32

Drawings are 1:1 scale

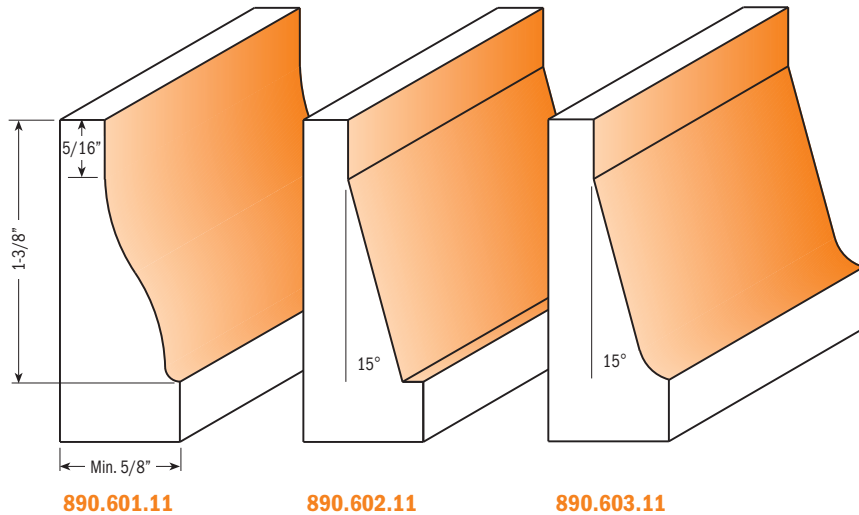

Make classic raised panel doors with CMT's industrial quality Raised Panel Bits. They feature micrograin carbide cutting edges, our trademark orange coating, and antikickback design for safety.



Safety Precautions:

These bits should be used between 10,000 and 12,000 RPM. Three to five passes recommended. To be used with routers with at least 2-1/4 HP.

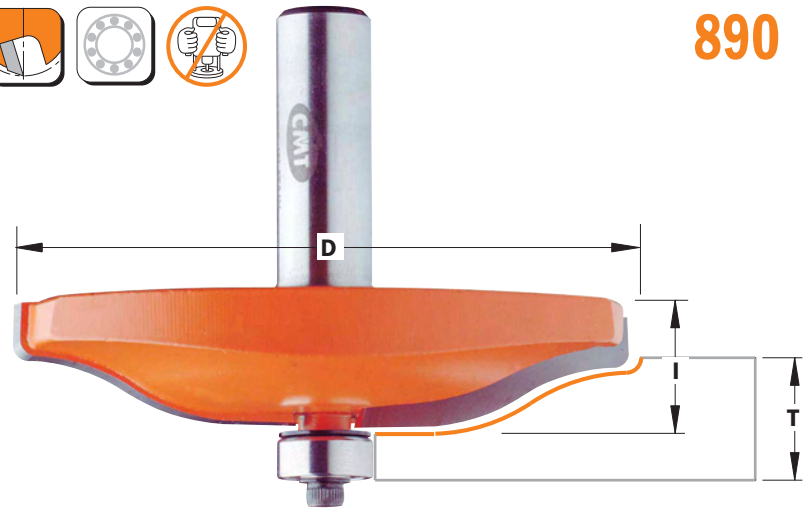

Order No. 1/2" shank	D_Cutting diameter inches mm	I_Cutting length inches	T_Joint thickness inches
890.501.11	3-1/4 82.5	19/32	19/32 - 23/32
890.502.11	3-1/4 82.5	19/32	19/32 - 23/32
890.503.11	3-1/4 82.5	19/32	19/32 - 23/32
890.504.11	3-1/2 89	19/32	23/32 - 25/32
890.505.11	3-1/2 89	19/32	23/32 - 25/32
890.506.11	3-1/2 89	19/32	23/32 - 25/32
890.507.11	3-1/2 89	19/32	23/32 - 25/32
890.512.11	1-7/8 47.6	3/8	1/2 - 19/32

spare parts: 990.423.00 1/2" shield 990.058.00 Screw for bearing, 1/8W screws
791.003.00 1/2" bearing 991.057.00 3/32" hex key for 1/8W screws

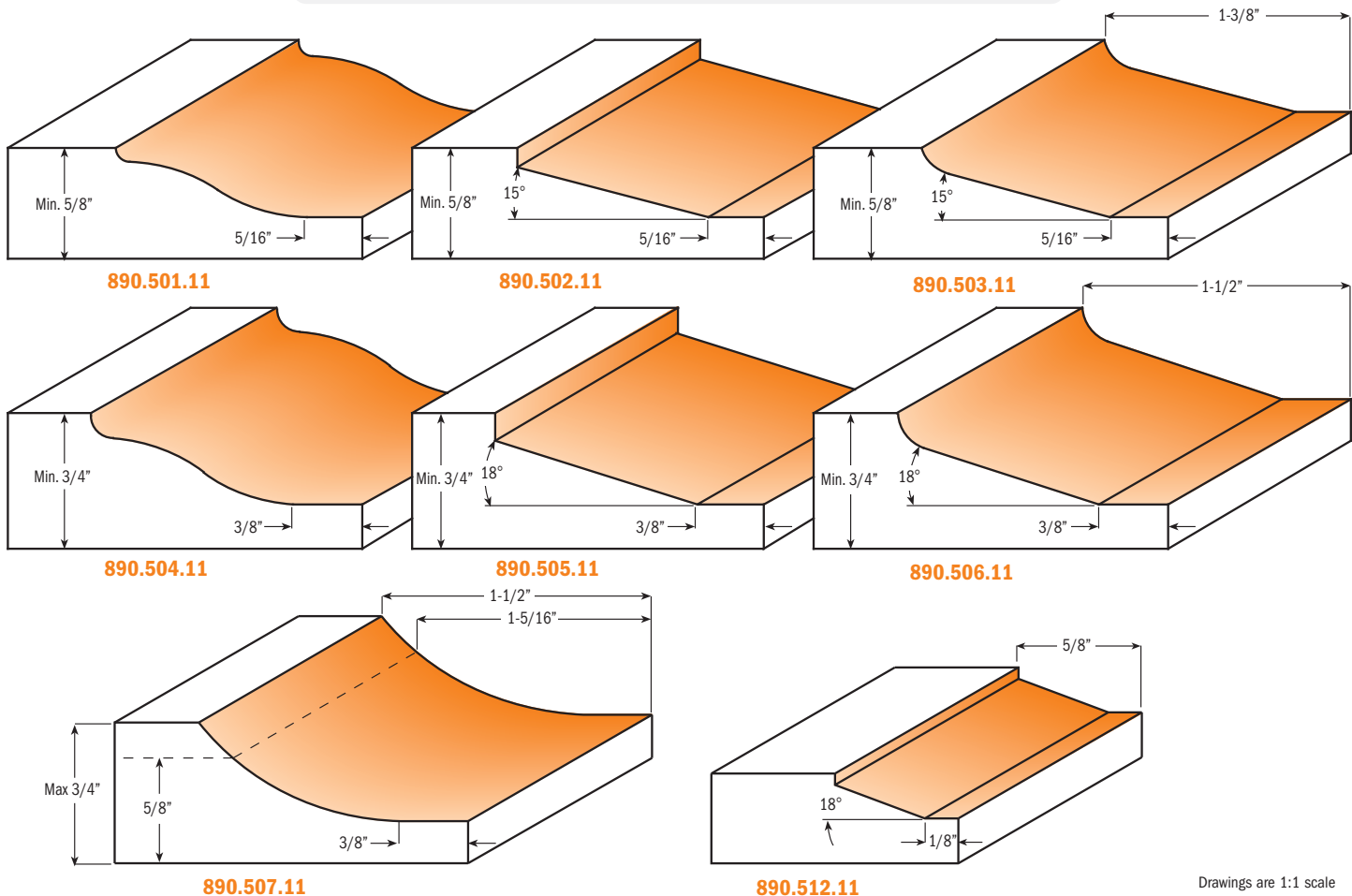

Drawings are 1:1 scale

Raised Panel Bits with Back Cutter

890.5



These innovative bits feature a back cutter which allows milling of both the front and back of the panel in the same cut. The bits are supplied with both 5/8" and 1-1/4" diameter bearings, allowing you to take two shallow passes for added safety.

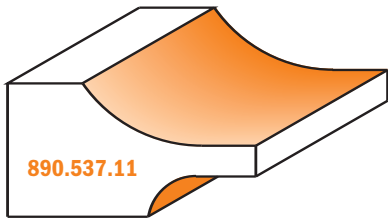
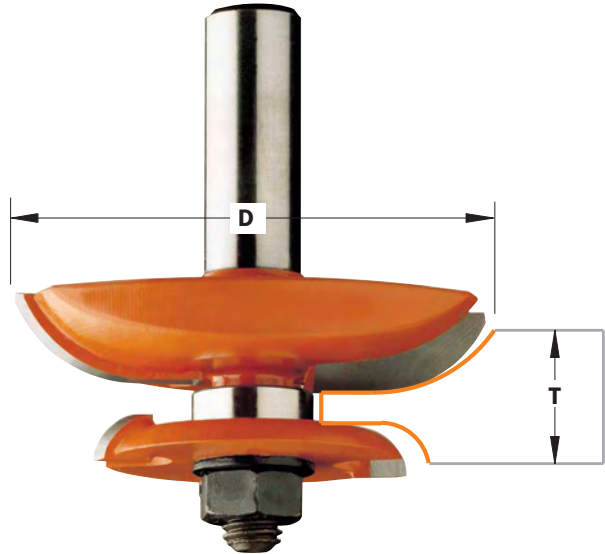

890.537.11

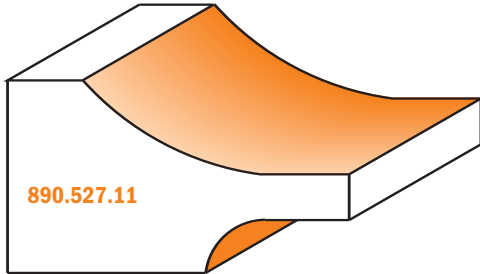

890.527.11

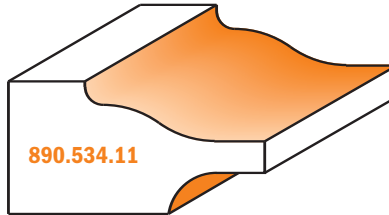

890.534.11

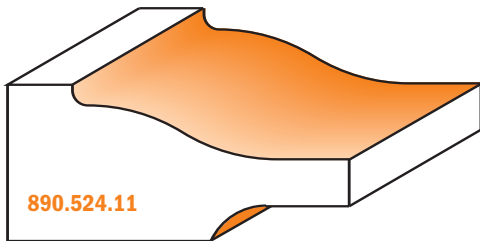

890.524.11

Drawings are 1:1 scale

Order No.	D_Cutting diameter		T_Joint thickness
	1/2" shank	inches	
890.537.11	2-1/2	63.5	7/16 - 11/16
890.527.11	3-1/2	89	3/4 - 1
890.534.11	2-1/2	63.5	7/16 - 11/16
890.524.11	3-1/2	89	3/4 - 13/16
spare parts:	822.007.11	5/16" two-flute slot cutter	541.516.00 0.3mm spacer
	822.010.11	1/4" two-flute slot cutter	541.517.00 0.5mm spacer
	791.025.00	16mm bearing	541.518.00 1mm spacer
	791.033.00	1-1/4" bearing	990.020.00 Nut, M8 thread
	541.515.00	0.1mm spacer	

Milling perfect raised panels

Fig. 1

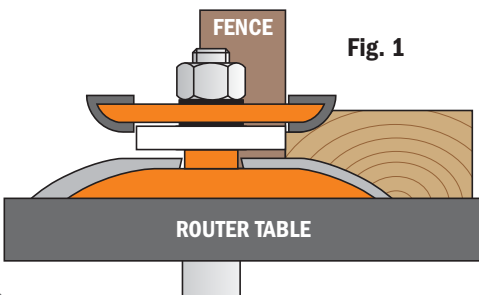
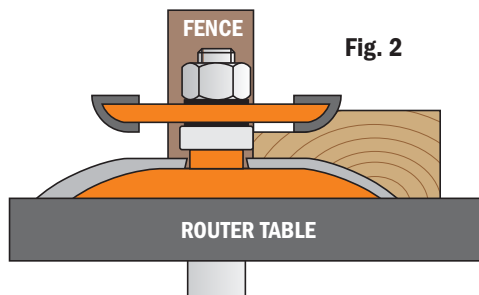

Fig. 2



First pass: Use the 1-1/4" diameter bearing supplied with the bit for your first pass. Set the router table fence to match the bearing position, and be sure to make a test cut in scrap stock.

Second pass: Use the 5/8" diameter bearing supplied with the bit for your second pass. Set the router table fence to match the bearing position, and be sure to make a test cut in scrap stock.

A well-constructed door must include a perfect rail and stile joint - clean, precise and well-crafted for strength. CMT's Rail and Stile Sets are the ideal choice for the job, with perfectly matched profiles, not the approximate match found on some reversible cutters. These bits rout joints in hard or soft woods from 11/16" to 7/8" thick. Choose the style that best suits your needs from the profiles below.



891.5

Order No. 1/2" shank	D_Cutting diameter		T_Joint thickness	B_Bearing diameter
	inches	mm	inches	mm
891.501.11	1-3/4	44.4	23/32 - 7/8	22
891.502.11	1-3/4	44.4	23/32 - 7/8	22
891.503.11	1-3/4	44.4	23/32 - 7/8	22
spare parts:	822.003.11	6mm two-flute slot cutter	541.516.00	0.3mm spacer
	791.012.00	22mm bearing	541.517.00	0.5mm spacer
	541.515.00	0.1mm spacer	990.020.00	Nut, M8 thread

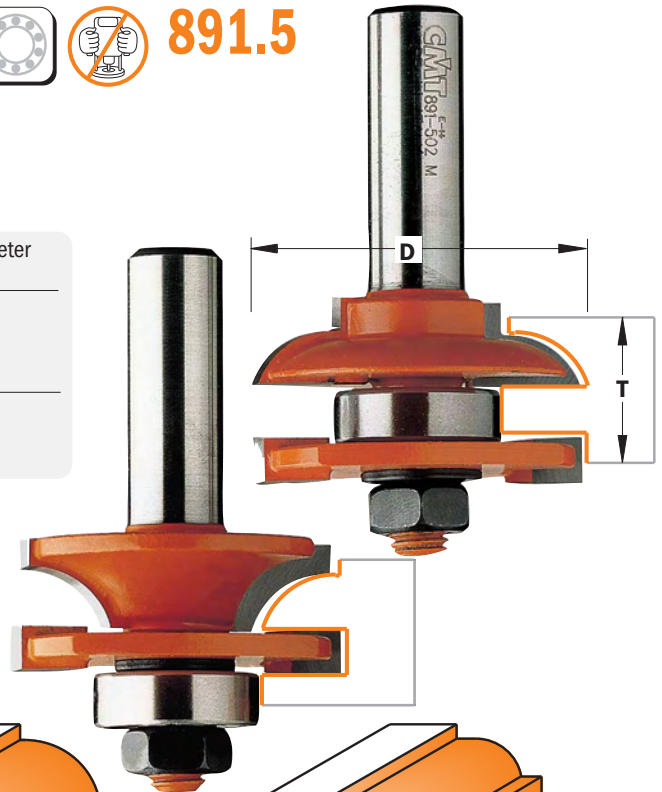

Drawings are 1:1 scale

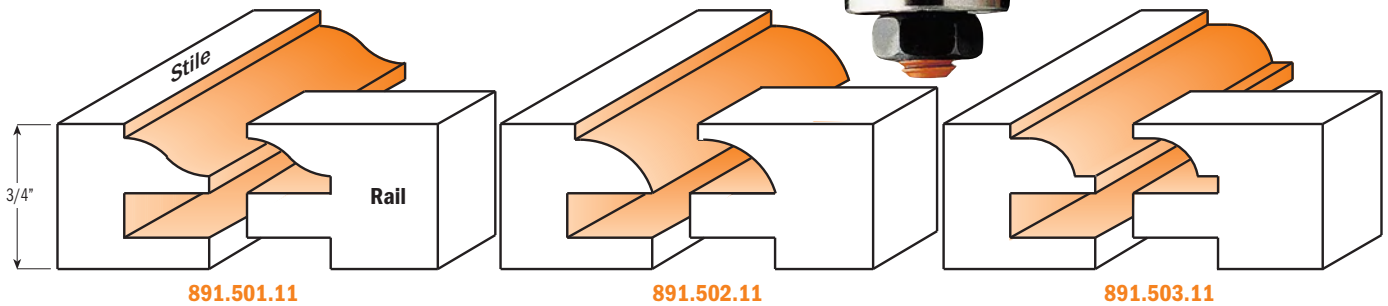

One piece Rail & Stile Bit

The new CMT One-Piece Rail and Stile Bit represents the union of two cutters in one bit, and provides an innovative, efficient means to mill stiles and rails. By simply adjusting the height of the bit, you can cut two perfectly matched profiles with no wasted time moving the fence or changing the bit. Save money by investing in a single CMT bit and more efficient production. For working in stock from 11/16" to 7/8" thick.



891.521

Safety Precautions: Always unplug the router before making any adjustments to the bit. Use push blocks and featherboards to control the workpiece.

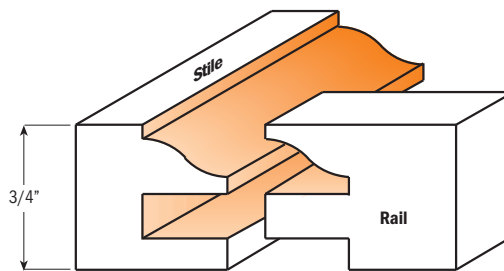

Drawings are 1:1 scale

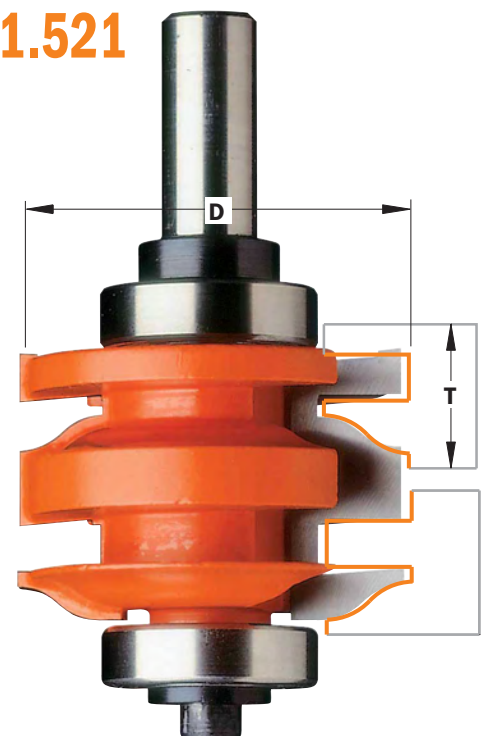

Order No. 1/2" shank	D_Cutting diameter		T_Joint thickness	B_Bearing diameter
	inches	mm	inches	inches
891.521.11	2	50.8	23/32 - 7/8	1-1/8
spare parts:	791.027.00	1-1/8" bearing		
	541.002.00	Stop collar for 1/2" shanks		
	990.010.00	Screw for bearing, M5 thread		
	541.551.00	Shield for screw M5		
	991.056.00	1.5mm hex key for stop collars		
	991.064.00	4mm hex key for screw M5		

891.517



These bits are designed for those special pro-jects that require a smaller panel door. Use these bits with stock from 7/16" to 11/16" thick, and build doors as small as 2-3/4" square.

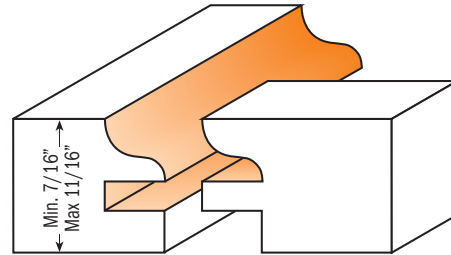
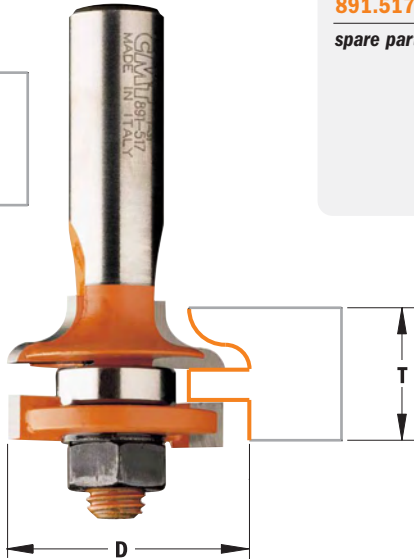

Drawings are 1:1 scale

Order No.	D_Cutting diameter	T_Joint thickness	B_Bearing diameter
1/2" shank	inches	mm	inches
891.517.11	1-1/4	31.7	7/16 - 11/16
spare parts:			
822.008.11	5/32" two-flute slot cutter		
822.009.11	15/64" two-flute slot cutter		
791.025.00	16mm bearing		
541.515.00	0.1mm spacer		
541.516.00	0.3mm spacer		
541.518.00	1mm spacer		
990.020.00	Nut, M8 thread		

Lonnie Bird's Rail & Stile Set

891.512



Designed for fine furniture construction, these bits mill a delicate 3/16" thumbnail profile in stock from 5/8" to 13/16" thick.

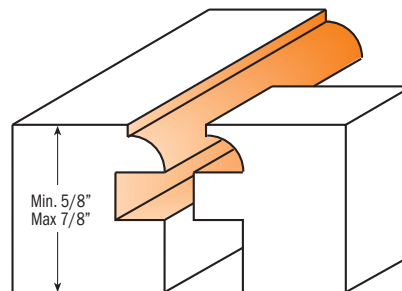
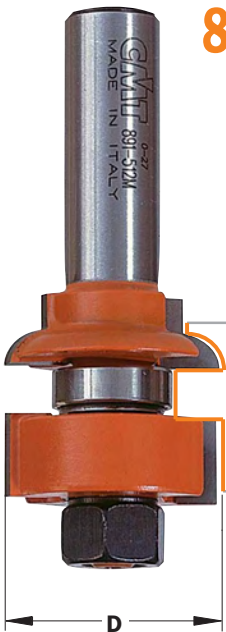

Drawings are 1:1 scale

Order No.	D_Cutting diameter	T_Joint thickness	B_Bearing diameter
1/2" shank	inches	mm	inches
891.512.11	1-1/8	28.7	5/8 - 7/8
spare parts:			
822.011.11	1/4" two-flute slot cutter		
822.012.11	13/32" two-flute slot cutter		
791.025.00	16mm bearing		
541.515.00	0.1mm spacer		
541.516.00	0.3mm spacer		
541.518.00	1mm spacer		
990.020.00	Nut, M8 thread		

In our step-by-step example of panel door construction, we used the following:

- CMT Rail & Stile set (item #891.502.11)
- CMT Reverse Glue Joint (item #855.501.11)
- pre-cut to length stiles - 3/4" thick x 2-1/4" wide
- pre-cut to length rails - 3/4" thick x 2-1/4" wide
- panel - 5/8" thick
- scrap stock for test cuts

The CMT Rail & Stile set was designed primarily for the construction of panel doors with 3/4" thick rails and stiles, but stock up to 7/8" thick can be used. Remember to adjust your measurements and cutting depths according to the wood thickness you use.

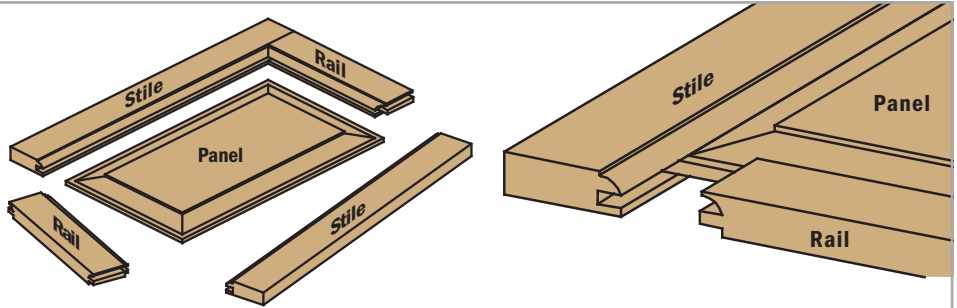

ILLUSTRATION A

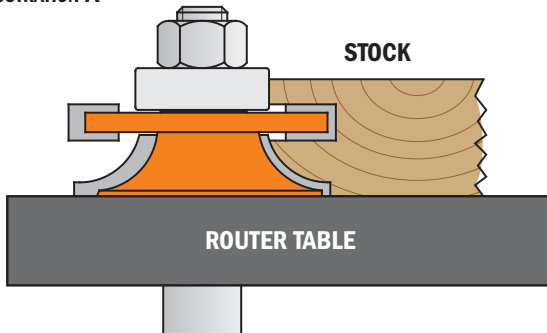
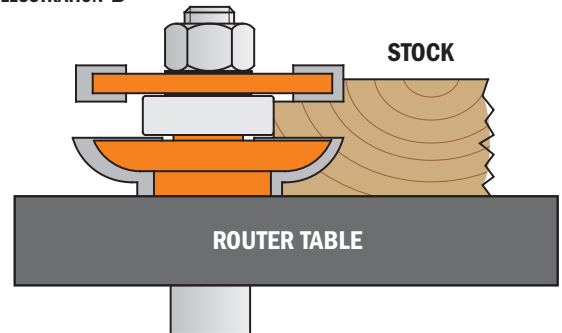

ILLUSTRATION B



MILLING THE RAILS AND STILES

First, make trial cuts of the cope profile (rail) and the stick profile (stile) in scrap stock and check the accuracy of the joint. This is extremely important, especially when working at the maximum thickness of 7/8". Make sure your stock is flat and cut straight with square edges. Using the CMT Stile Bit shown in illustration A, place the stock face down on the router table and mill the stick profile in the stile and rail pieces. To mill the rails, use the CMT Rail Bit shown in illustration A, position the rails face down on the router table and mill the cope profile in the ends. Before cutting the rails to length, be sure to allow enough length for the overlap of the cope and stick profiles. The stiles are the same length as the door. The rails must be calculated by the following equation (CMT standard tenon length is 7/16"):

(total door width - sum of stile widths) + sum of 2 tenons = total rail length
 therefore, using our example measurements listed above, for a 12" wide cabinet door:
 $12" - 4 \cdot 1/2" + 7/8" = 8 \cdot 3/8"$ rail length

ILLUSTRATION C

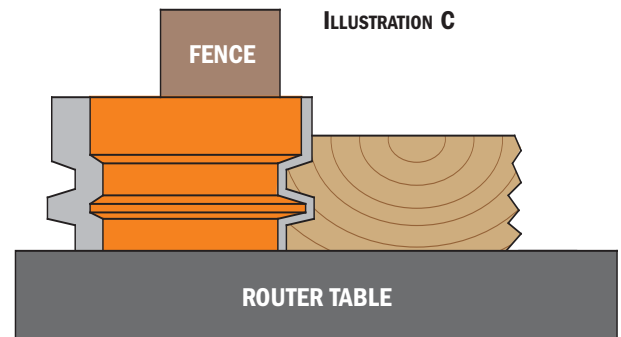

GLUING UP PANELS

If the panel requires a width greater than the width of your stock, you will need to edge glue stock for the central floating panel. This is easily accomplished using the CMT Reverse Glue Joint bit. For a two panel glue joint, place the first panel face down on the router table and accurately centre the wood to the bit: Adjust the bit according to the thickness of the wood you are cutting by lining up the cut edge of the wood to the center point of the bit as illustrated in illustration B and mill the cut edge of the wood. Place the second panel face up and repeat the milling process. This assures you will have the best side of your stock as a front face. If a third panel is required, mill one cut edge of the piece as instructed above, turn the piece over and run the other edge. Assemble the reverse cut pairs together for beautiful, strong joints that match up perfectly.

MILLING THE FLOATING PANEL

To cut your panel to size be sure to make the proper calculations, taking into account the length of the tongue. The CMT Raised Panel Bit in our example has a standard tongue length of 5/16" (The New CMT Raised Panel Bit profile has a 3/8" tongue).

Use the following equation:
 (Total door length - Sum of Stile widths) + Sum of 2 Tongues = Overall Panel Length

Therefore, using our example measurements listed above for a 24" long cabinet door: $(24 - 4 \cdot 1/2") + 5/8" = 20 \cdot 1/8"$ panel length

And accordingly:

(Total door width - Sum of Stile widths) + Sum of 2 Tongues = Overall Panel Width.

Once the panel has been cut to proper dimensions, position the panel face side down on the router table as shown in illustration C and use the CMT Raised Panel Bit to mill the tongue. **ATTENTION:** this bit is capable of removing large amounts of stock. To safely and effectively produce the profile you want, we suggest making several shallow passes. It can be dangerous to try to mill the entire profile in a single cut.

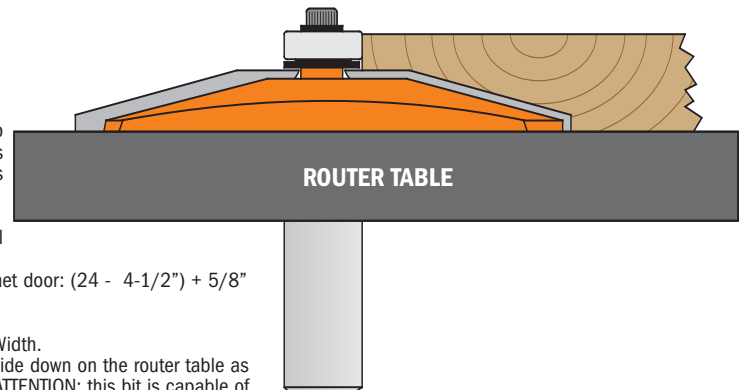

15 piece Router Bit Set

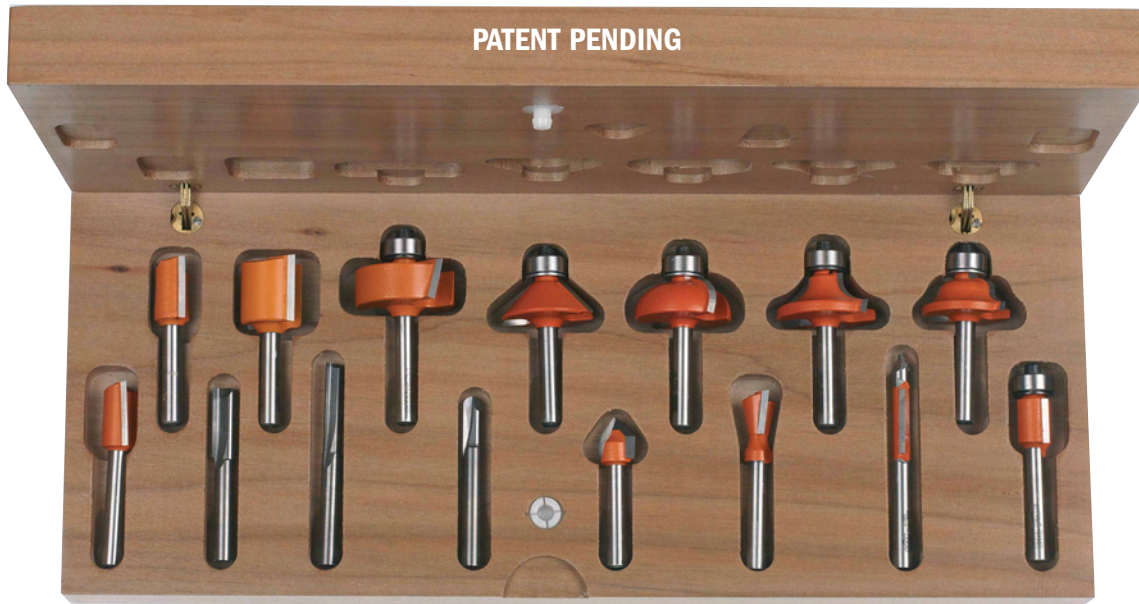

Order No. **800.001.00** 15 piece Router Bit Set **1/4" shank**

Set contains	Order No. 1/4" shank	D_Cutting diameter inches mm	I_Cutting length inches mm	R_Cutting radius inches mm	A_Cutting angle	H_Cutting depth inches mm
Straight bit	811.080.11	5/16 8	3/4 19			
Straight bit	812.060.11	15/64 6	1 25.4			
Straight bit	811.120.11	12 3/4 19				
Straight bit	811.200.11	20 3/4 19				
Mortising bit	801.127.11	1/2 12.7	3/4 19			
Roundover bit	838.317.11	1-1/4 31.7	9/16 14	3/8 9.5		
Ogee bit	840.270.11	1-1/8 28.7	29/64 11.5	5/32 4		
Rabbeting bit	835.317.11	1-1/4 31.7	1/2 12.7			3/8 9.5
Chamfer bit	836.280.11	1-1/4 31.7	3/8 9.5		45°	
Cove bit	837.286.11	1-1/4 31.7	1/2 12.7	3/8 9.5		
Round nose bit	814.064.11	1/4 6.35	1/2 12.7	1/8 3.17		
V-Groove bit 90°	815.127.11	1/2 12.7	1/2 12.7		90°	
Dovetail bit	818.128.11	1/2 12.7	1/2 12.7		14°	
Panel pilot bit	816.064.11	1/4 6.35	3/4 19			
Flush trim bit	806.128.11	1/2 12.7	1/2 12.7			

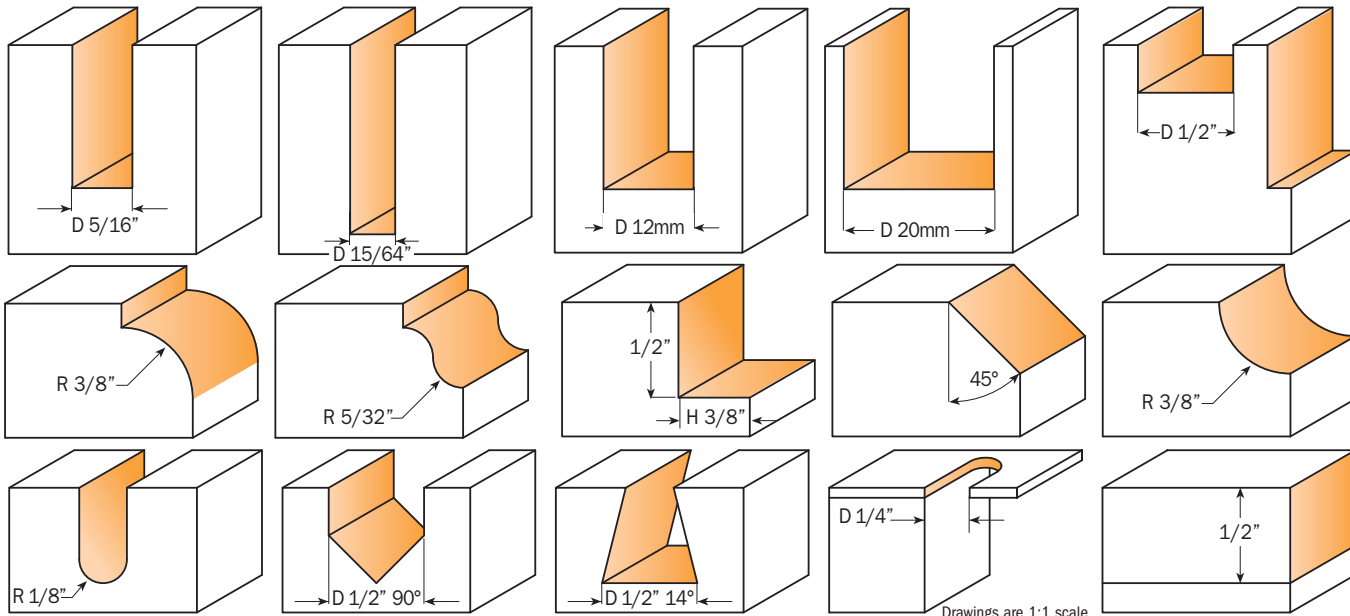

Drawings are 1:1 scale

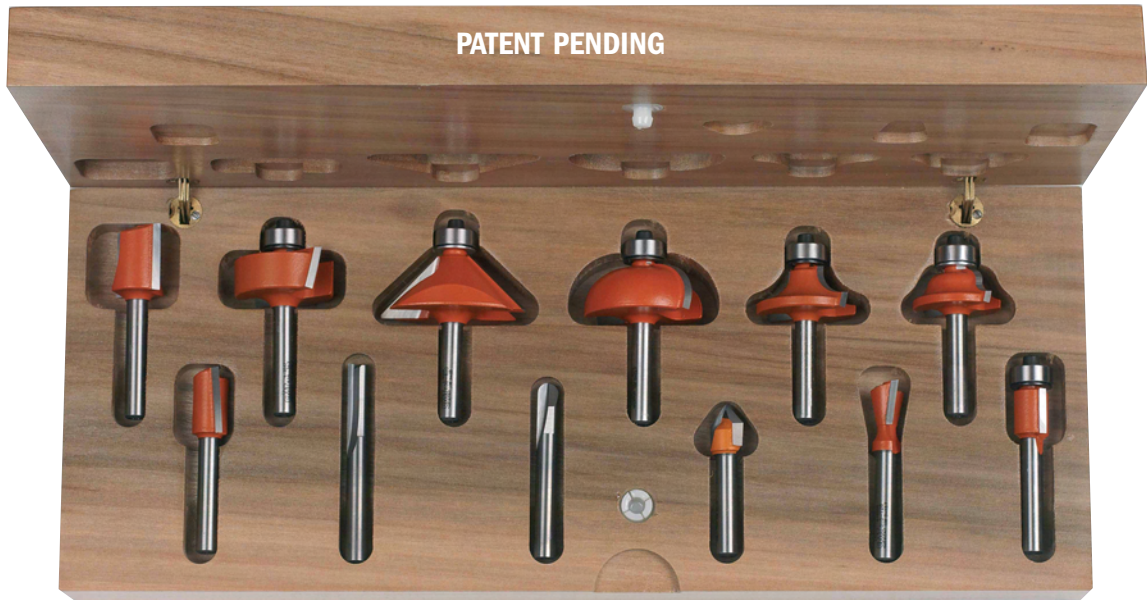

Order No. 800.503.11 12 piece Router Bit Set **1/4" shank**

Set contains	Order No. 1/4" shank	D_Cutting diameter inches mm	I_Cutting length inches mm	R_Cutting radius inches mm	A_Cutting angle	H_Cutting depth inches mm
Flush trim bit	806.128.11	1/2 12.7	1/2 12.7			
Cove bit	837.350.11	1-1/2 38.1	5/8 15.5	1/2 12.7		
Rabbeting bit	835.317.11	1-1/4 31.7	1/2 12.7			3/8 9.5
Roundover bit	838.317.11	1-1/4 31.7	9/16 14	3/8 9.5		
Chamfer bit	836.420.11	1-3/4 45	5/8 15.5		45°	
Ogee bit	840.270.11	1-1/8 28.7	29/64 11.5	5/32 4		
Straight bit	811.065.11	1/4 6.35	3/4 19			
Straight bit	811.191.11	3/4 19	3/4 19			
Mortising bit	801.127.11	1/2 12.7	3/4 19			
Round nose bit	814.064.11	1/4 6.35	1/2 12.7	1/8 3.17		
V-Groove bit 90°	815.127.11	1/2 12.7	1/2 12.7		90°	
Dovetail bit	818.128.11	1/2 12.7	1/2 12.7		14°	

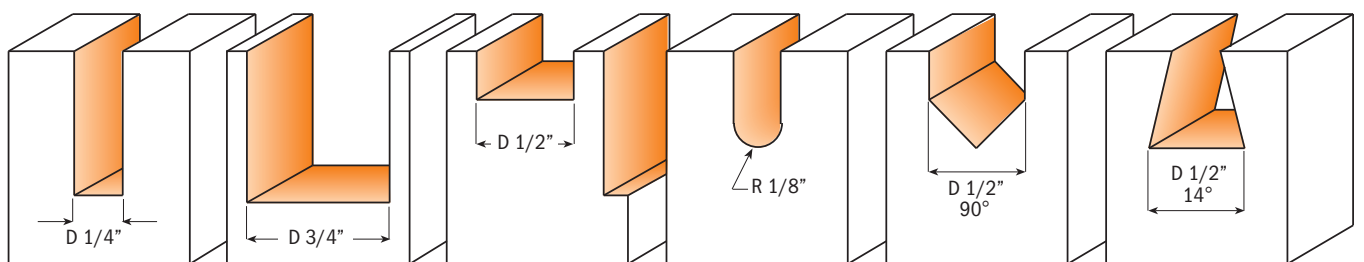
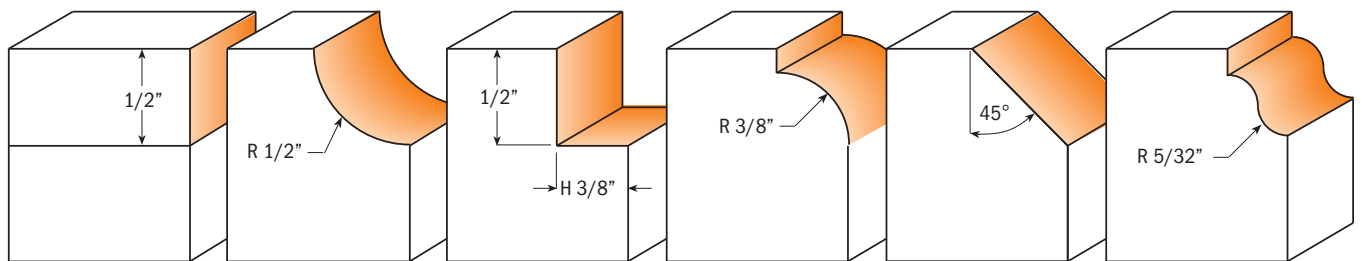

Drawings are 1:1 scale

13 piece Router Bit Set

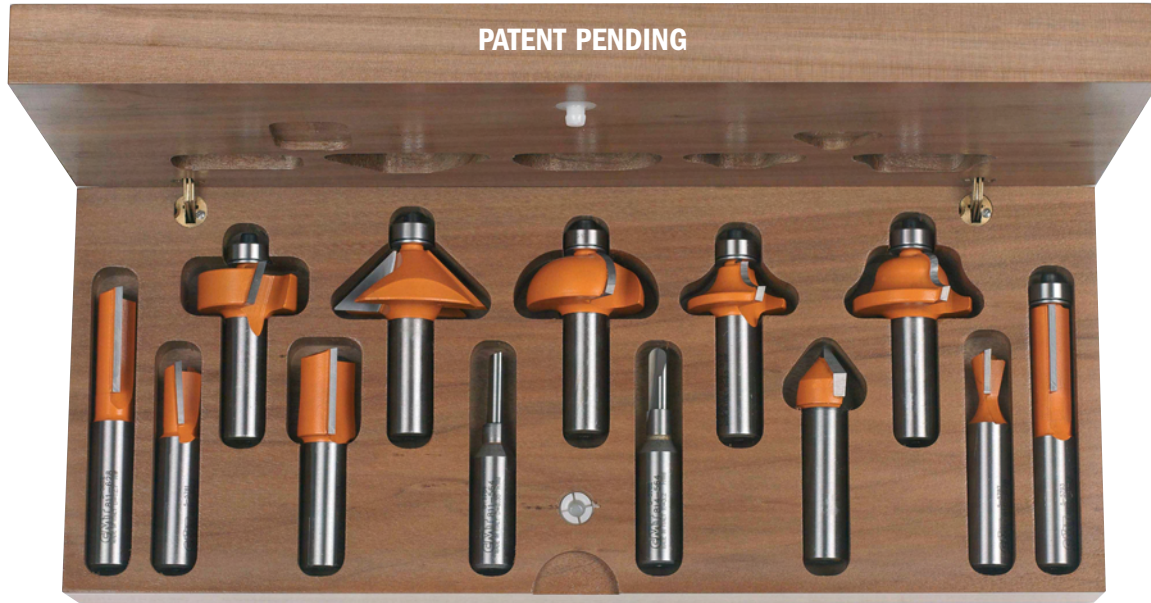

Order No. **800.505.11** 13 piece Router Bit Set **1/2" shank**

Set contains	Order No. 1/2" shank	D_Cutting diameter		I_Cutting length		R_Cutting radius		A_Cutting angle	H_Cutting depth	
		inches	mm	inches	mm	inches	mm		inches	mm
Straight bit	811.564.11	1/4	6.35	3/4	19					
Straight bit	811.628.11	1/2	12.7	1	25.4					
Flush trim bit	806.627.11	1/2	12.7	1	25.4					
Straight bit	811.690.11	3/4	19	1	25.4					
Mortising bit	801.627.11	1/2	12.7	3/4	19					
Roundnose bit	814.564.11	1/4	6.35	5/8	15.87	1/8	3.17			
V-Groove bit 90°	815.690.11	3/4	19	5/8	15.87			90°		
Dovetail bit 14°	818.628.11	1/2	12.7	1/2	12.7			14°		
Cove bit	837.850.11	1-1/2	38.1	5/8	15.87	1/2	12.7			
Rabbeting bit	835.817.11	1-1/4	31.7	1/2	12.7				3/8	9.5
Roundover bit	838.817.11	1-1/4	31.7	9/16	14.2	3/8	9.5			
Ogee bit	840.850.11	1-1/2	38.1	11/16	17.4	1/4	6.35			
Chamfer bit 45°	836.920.11	1-3/4	19.05	23/32	18.2			45°		

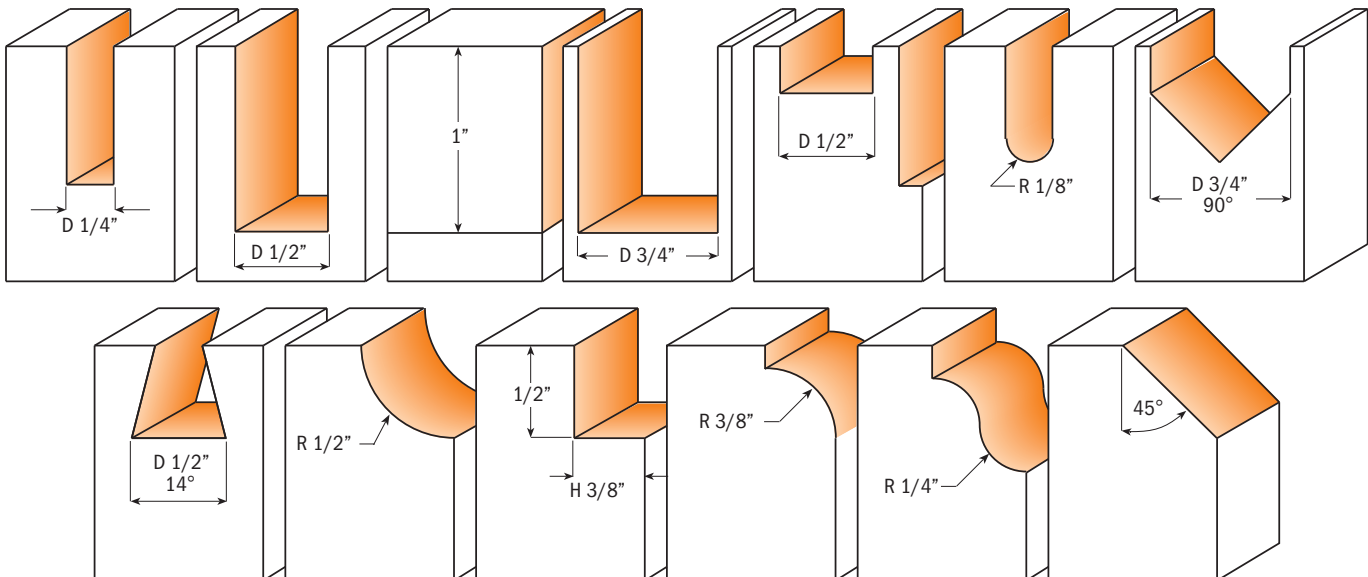

Drawings are 1:1 scale

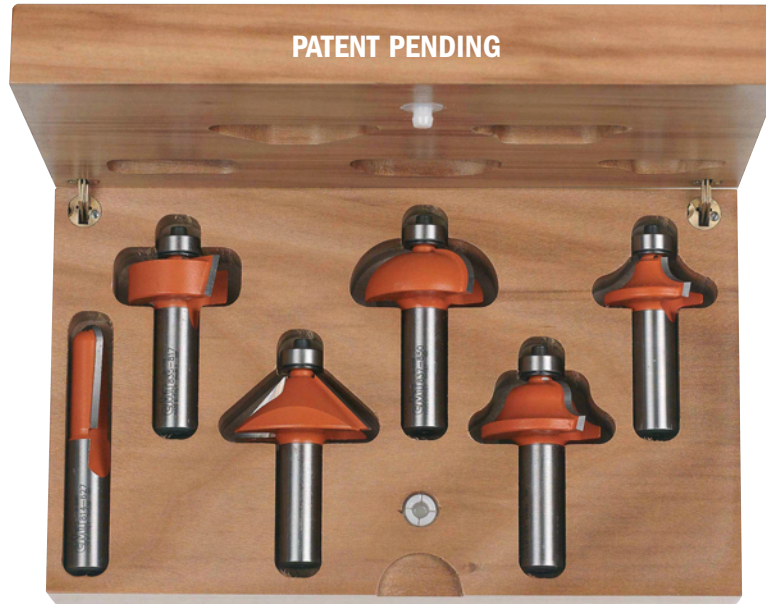

Improve the quality and variety of profile bits in your shop with this economical set. The compact hardwood case includes six great bits: round nose, cove, rabbeting, roundover, ogee and chamfer. All of these tools feature the finest steel and carbide, plus CMT's baked-on orange nonstick coating. All bits are 1/2" shank.

Order No. **800.504.11** 6 piece Router Bit Set **1/2" shank**

Set contains	Order No. 1/2" shank	D_Cutting diameter		L_Cutting length		R_Cutting radius		A_Cutting angle	H_Cutting depth	
		inches	mm	inches	mm	inches	mm		inches	mm
Rabbeting bit	835.817.11	1-1/4	31.7	1/2	12.7				3/8	9.5
Cove bit	837.850.11	1-1/2	38.1	5/8	15.87	1/2	12.7			
Roundover bit	838.817.11	1-1/4	31.7	9/16	14.2	3/8	9.5			
Roundnose bit	814.627.11	1/2	12.7	1-1/4	31.7	1/4	6.35			
Chamfer bit 45°	836.920.11	1-3/4	19.05	23/32	18.2			45°		
Ogee bit	840.850.11	1-1/2	38.1	11/16	17.4	1/4	6.35			

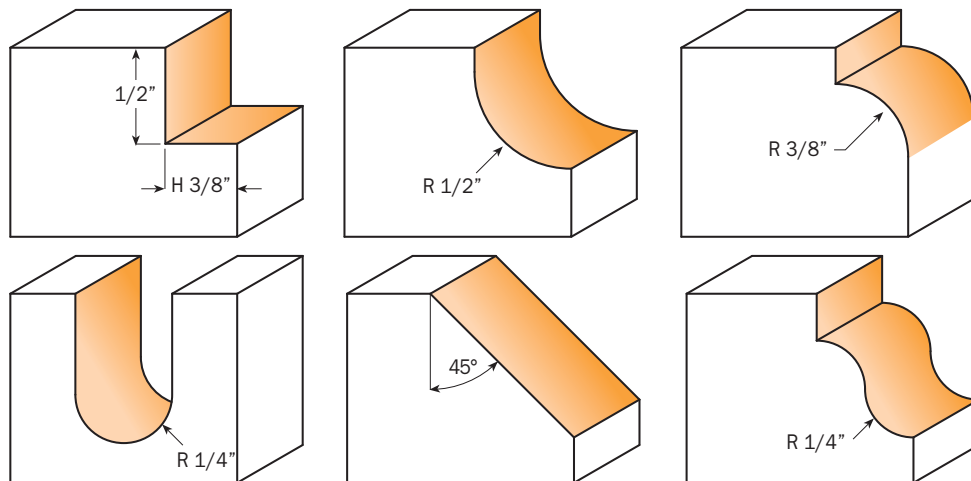

Drawings are 1:1 scale

8 piece Dovetail & Straight Router Bit Set

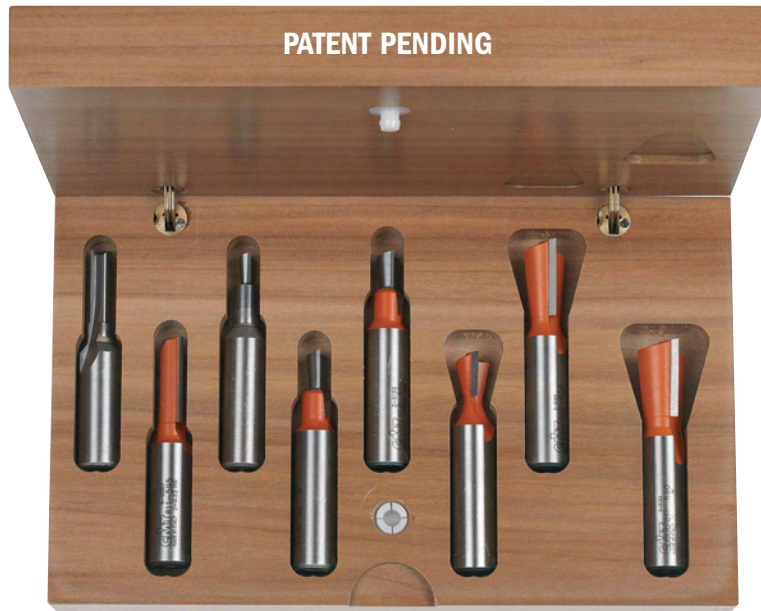

IDEAL FOR INCRA & JOINTECH JIGS. Also suitable for many other jigs.

Order No. 800.500.11 8 piece Dovetail & Straight Router Bit Set **1/4" shank**

Set contains	Order No. 1/4" shank	A_Cutting angle	D_Cutting diameter inches mm	I_Cutting length inches mm	L_Overall Length inches mm	Incra Template
Straight bit	811.065.11		1/4 6.35	3/4 19	2-1/4 57.1	Box #4 & 5
Straight bit	811.096.11		3/8 9.5	1 25.4	2-1/2 63.5	Box #1,2 & 3
Dovetail bit	818.064.11	7.5°	1/4 6.35	5/16 8	2-1/2 63.5	Dove #8
Dovetail bit	818.080.11	9°	5/16 8	3/8 9.5	2-1/2 63.5	Dove. I #7
Dovetail bit	818.096.11	9°	3/8 9.5	3/8 9.5	2-1/16 52.3	Dove #5, 6, 1DD2
Dovetail bit	818.128.11	14°	1/2 12.7	1/2 12.7	2-1/16 52.3	Dove #1, 2, 3 & 4 1DD1
Dovetail bit	818.158.11	7°	5/8 15.8	7/8 22.2	2-3/8 60.3	Dove #10
Dovetail bit	818.190.11	7°	3/4 19	7/8 22.2	2-3/8 60.3	Dove #9

Order No. 800.501.11 8 piece Dovetail & Straight Router Bit Set **1/2" shank**

Set contains	Order No. 1/2" shank	A_Cutting angle	D_Cutting diameter inches mm	I_Cutting length inches mm	L_Overall Length inches mm	Incra Template
Straight bit	811.564.11		1/4 6.35	3/4 19	2-3/8 60.3	Box #4 & 5
Straight bit	811.595.11		3/8 9.5	1 25.4	2-5/8 66.6	Box #1,2 & 3
Dovetail bit	818.564.11	7.5°	1/4 6.35	5/16 8	2-1/2 63.5	Dove #8
Dovetail bit	818.580.11	9°	5/16 8	3/8 9.5	2-1/2 63.5	Dove. I #7
Dovetail bit	818.596.11	9°	3/8 9.5	3/8 9.5	2-1/2 63.5	Dove #5, 6, 1DD2
Dovetail bit	818.128.11	14°	1/2 12.7	1/2 12.7	2-1/2 63.5	Dove #1, 2, 3 & 4 1DD1
Dovetail bit	818.658.11	7°	5/8 15.8	7/8 22.2	2-5/8 66.6	Dove #10
Dovetail bit	818.690.11	7°	3/4 19	7/8 22.2	2-5/8 66.6	Dove #9

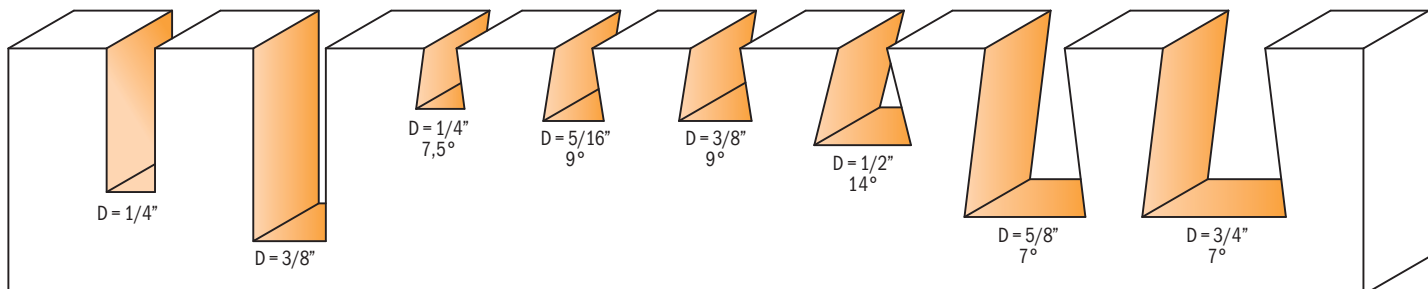

Drawings are 1:1 scale

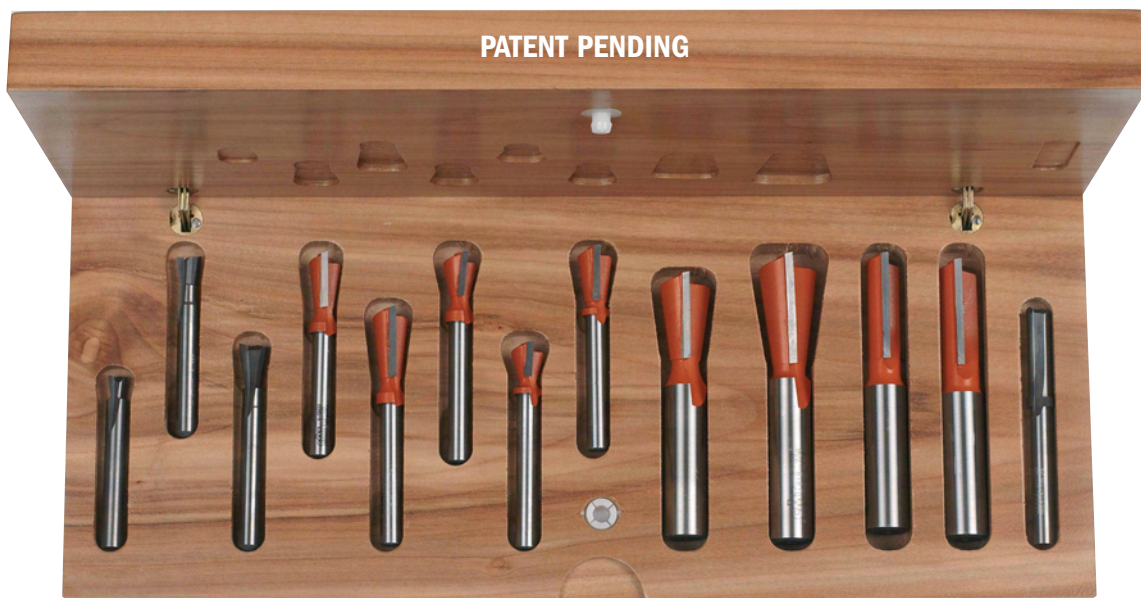

IDEAL FOR LEIGH D4 JIG. Also suitable for many other jigs.

Order No. **800.519.11** 13 piece Dovetail & Straight Router Bit Set **1/4" & 1/2" shank**

Set contains	Order No. 1/4" shank	Order No. 1/2" shank	A_Cutting angle	D_Cutting diameter inches	mm	I_Cutting length inches	mm	L_Overall length inches	mm	Leight No.
Dovetail bit	818.065.11		8°	1/4	6.35	1/4	6.35	2	50.8	50
Dovetail bit	818.081.11		8°	5/16	8	3/8	9.5	2-1/8	53.9	60
Dovetail bit	818.097.11		8°	3/8	9.5	1/2	12.7	2-3/8	60.3	70
Dovetail bit	818.111.11		8°	7/16	11.1	5/8	15.8	2-3/8	60.3	75
Dovetail bit	818.129.11		8°	1/2	12.7	13/16	20.6	2-3/4	69.8	80
Dovetail bit	818.130.11		14°	1/2	12.7	1/2	12.7	2-7/16	61.9	120
Dovetail bit	818.132.11		18°	1/2	12.7	13/32	20.6	2-3/8	60.3	128
Dovetail bit	818.133.11		10°	1/2	12.7	5/8	15.8	2-3/8	60.3	101
Dovetail bit		818.674.11	8°	11/16	17.4	1	25.4	3-1/16	77.7	90
Dovetail bit		818.706.11	8°	13/16	20.6	1-1/4	31.7	3-5/16	84.1	100
Straight bit		811.628.11		1/2	12.7	1-1/4	31.7	3-1/4	82.5	160
Straight bit		812.611.11		7/16	11.1	1-1/4	31.7	3-1/4	82.5	150
Straight bit	811.081.11			5/16	8	1	25.4	2-13/16	71.4	140

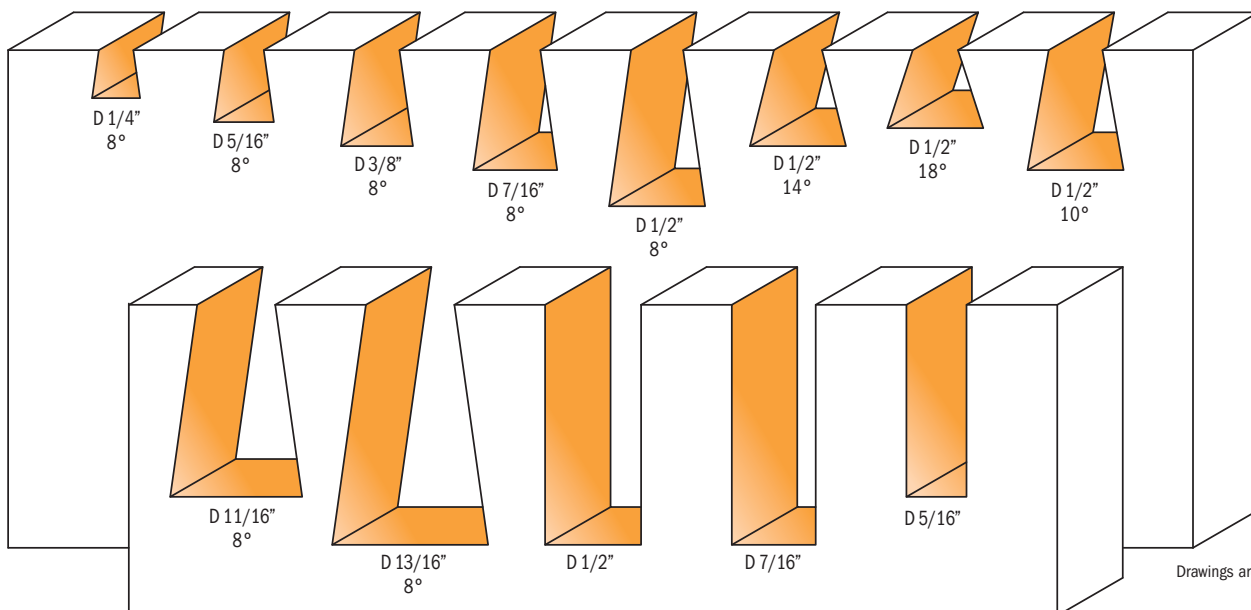

Drawings are 1:1 scale

Tenon Cutting Router Bit

PATENT PENDING

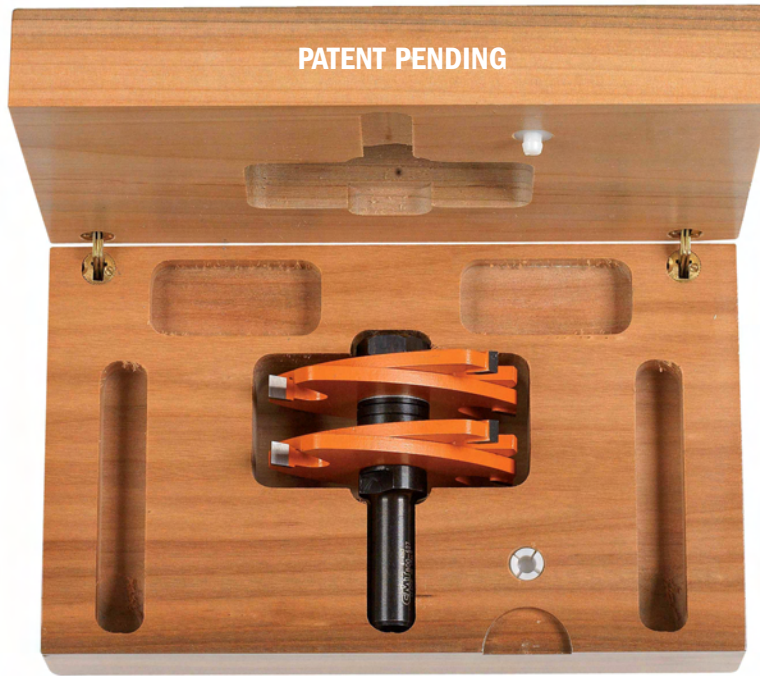

Assembly illustration

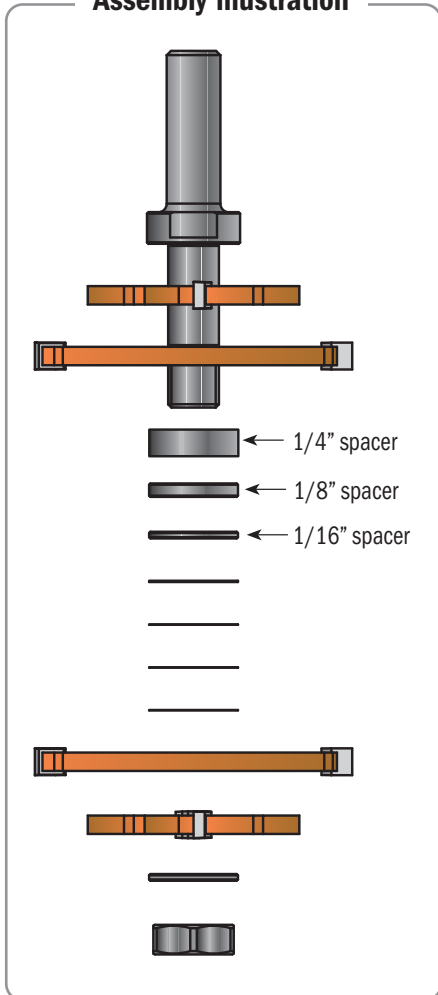

Cut perfectly fitting tenons, every time.

If you've struggled cutting tenons that fit, here's the perfect solution for precise tenons. CMT's new tenon cutting router bit will produce perfectly fitting tenons in every board you cut, even if the boards vary slightly in thickness. Simply set the distance between the cutters using the included spacers, and you can easily cut tenons from 3/16-in. to 3/8-in. thick, up to 1-1/16-in. long. This simple-to-use router bit takes the mystery out of achieving the excellent tenon-to-mortise fit required for high quality joinery.

Tenon Cutting	No. Spacer		
	1/4"	1/8"	1/16"
3/16"	1	0	0
1/4"	1	0	1
5/16"	1	1	0
3/8"	1	1	1

Safety Precautions: Maximum speed: 12,000 rpm.
Router table only.

DVD video and Instruction Manual are included!

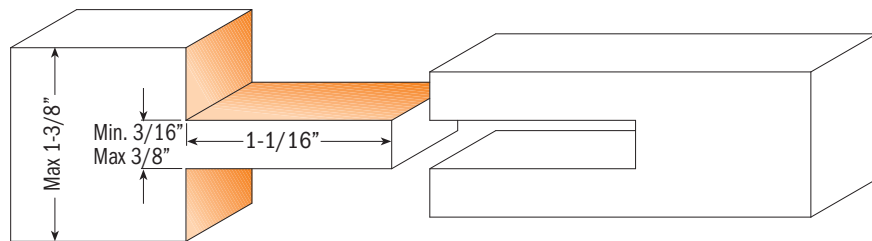

Drawings are 1:1 scale

Order No. **800.627.11** Tenon Cutting Router Bit Set **1/2" shank**

Order No.	I_Cutting length	D_Cutting diameter	H_Cutting depth	L_Overall length
1/2" shank	inches	mm	inches	inches
800.627.11	1-3/8	34.9	2-61/64	3-5/16

spare parts:

824.134.00	Arbor 1/2" shank
822.020.11	Slot cutter 1/4"
541.521.00	Spacer 1/16"
541.522.00	Spacer 1/8"
541.523.00	Spacer 1/4"
541.513.00	Spacer 0.1mm
541.520.00	Spacer 0.3mm
990.022.00	Nut for arbor, M12x1.25mm

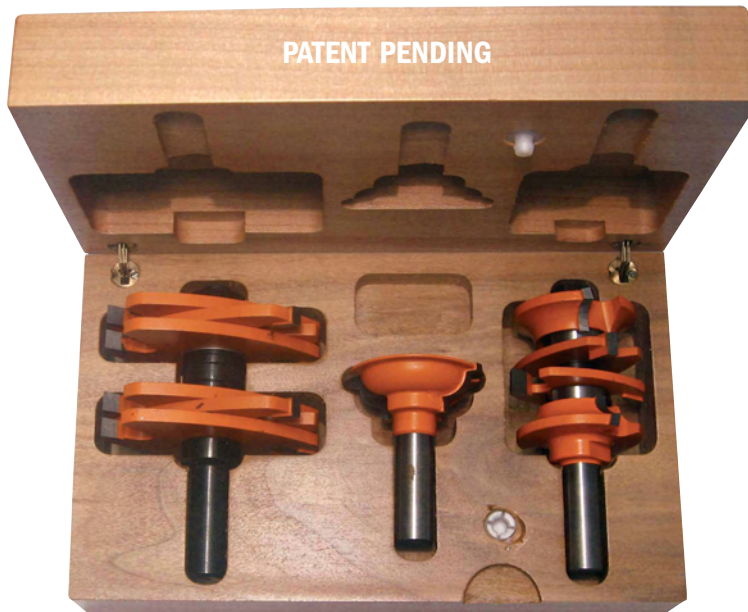

The new CMT three-piece set simplifies door construction, making it easy as 1, 2, 3!
 It is not the only advantage in fact this is a multi functional set for door makers and furniture makers building entry doors, passage doors and any furniture tenons. The included tenon cutter produces a beefy 1-1/16" long tenon. Coupled with the cope cutter, you can produce long and strong tenons with minimum set up. As an extra bonus the tenon cutter can be used for furniture making work that requires any tenon from 3/16" to 5/8" thick.

Order No. **800.527.11** 3 piece Entry & Interior Door Router Bit Set **1/2" shank** Roundover Profile

Set contains	Order No. 1/2" shank	D_Cutting diameter inches mm	I_Cutting length inches mm	T_Stock thickness inches	L_Overall length inches	B_Bearing mm
Tenon cutting router bit	800.628.11*	3 76	1-3/4 44.5	1-3/8 to 1-3/4	4	
Rail & stile router bit set	855.806.11	1-7/8 47.6	1-3/4 44.5	1-3/8 to 1-3/4	4	22

* Tenon cutting router bit 800.628.11 is a Patent Pending of C.M.T. Utensili S.p.A.

DVD video and Instruction Manual are included!

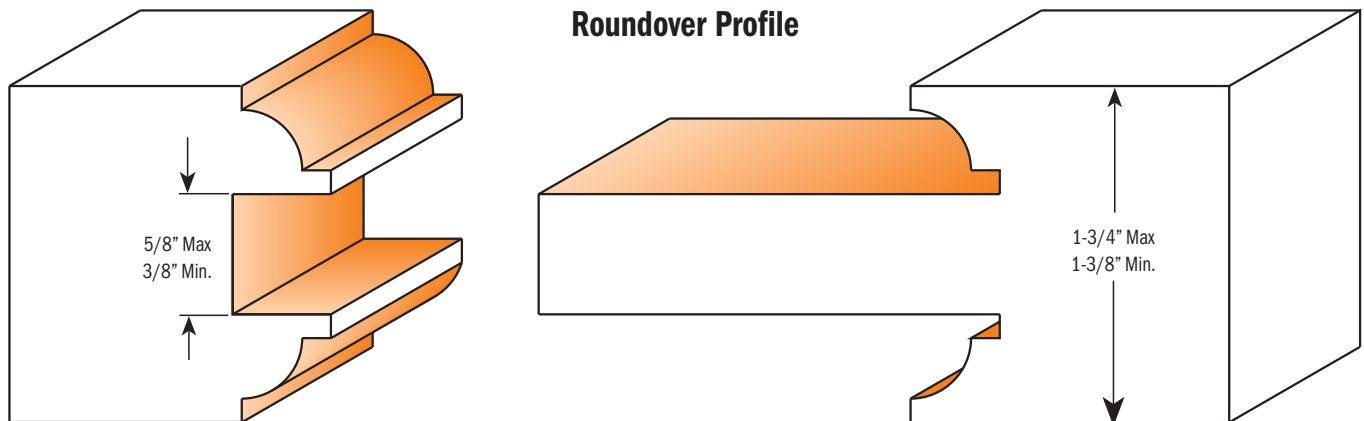

Entry & Interior door construction - Easy as 1, 2, 3!

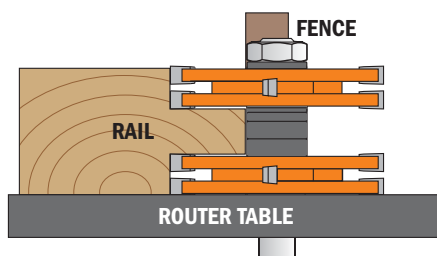

Step 1. Cut the tenon in the rails

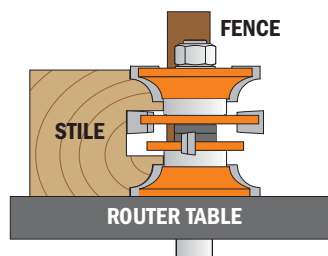

Step 2. Cut the groove and door profile in all the pieces.

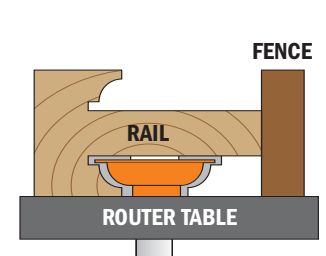

Step 3. Undercut the tenons to cope the ends of the rails.

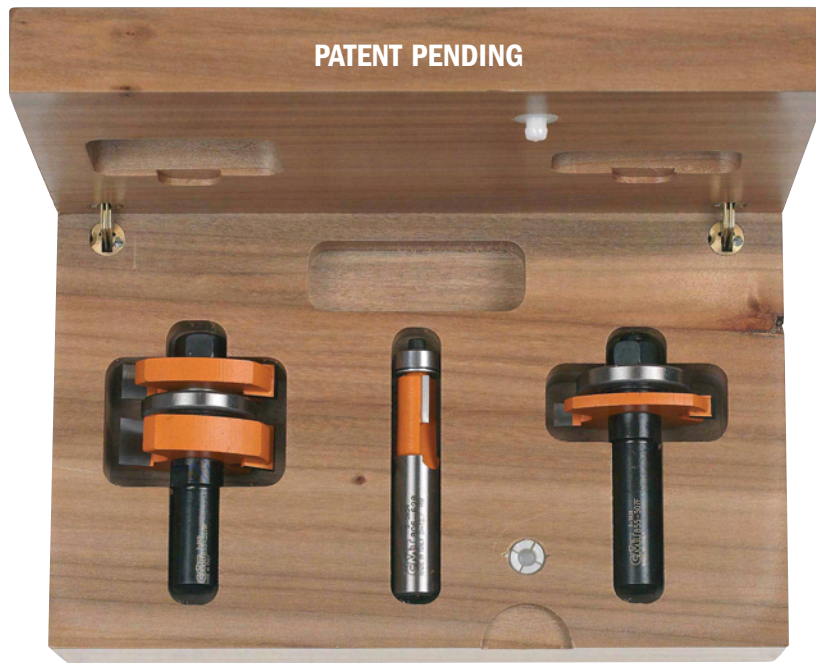

CMT has developed a tongue and groove cabinet making system that derives from the superior traditional European methods of joinery. Combine the CMT tongue and groove system with the ease and speed of new world pocket hole methods and you have the versatility to build single cabinets or entire kitchens!!

The CMT Tongue and Groove Set includes a matched set that produce a 1/4" x 1/4" tongue. The feature of the CMT system that sets it apart from other tongue and groove sets is that the tongue is offset to one side of the joint. This system produces a stronger joint allowing for more drilling area when used in conjunction with the CMT Pocket Pro when employing face frame screws. When the Pocket Pro is set at the one inch setting the screw will bypass the tongue and get a full bite in the grooved section, producing a much stronger joint. In some cabinet making applications, it is necessary to trim portions of the tongue. For this reason, we have included a 1/2" shank flush trim bit to complete the three piece set.

The CMT tongue and groove joint is used in every element of joining cabinets. When used in conjunction with the CMT Pocket Pro System you will be able to employ the best facets of traditional European joinery with new world methods for face frame joints and in completely concealed areas where bottoms, sides and dividers are attached to the face frame.

The original CMT Tongue and Groove Cabinet Making System is manufactured in Italy. You can be assured that you are buying original CMT products by analyzing the shank of CMT router bits. All genuine CMT bits have the words, "Made in Italy" laser etched into the shank.

Order No. 800.526.11 3 piece Tongue & Groove Cabinetmaking Set 1/2" shank

Set contains	Order No. 1/2" shank	D_Cutting diameter inches mm	I_Cutting length inches mm	L_Overall length inches mm	T_Stock thickness inches	H_Cutting depth inches
Tongue & Groove bit	855.507.11	1-3/4 44.5	1-1/8 28.6		1/2 to 1-1/8	1/4 to 1/2
Flush trim bit	806.628.11	1/2 12.7	1/2 12.7	2-3/4 70		

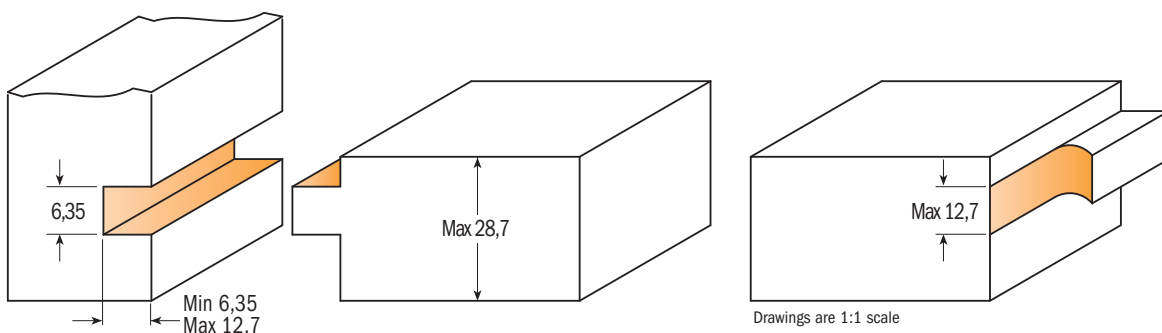

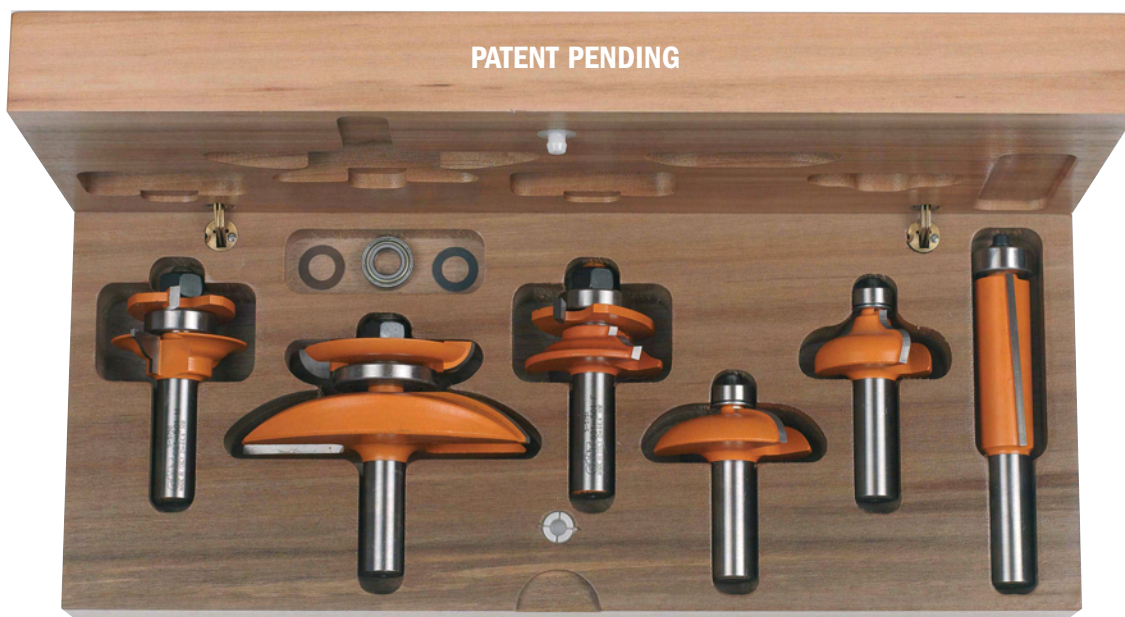

Order No. 800.515.11 6 piece Cove Cabinetmaking Set **1/2" shank**

Set contains	Order No. 1/2" shank	D_Cutting diameter inches mm	I_Cutting length inches mm	R_Cutting radius inches mm	L_Overall length inches	B_Bearing inches
Cove raised panel w/back cutter	890.527.11	3-1/2 89	1-1/8 28.6	1-1/2 38.1	3-1/16	1-1/4 & 16mm
Ogee rail & stile bits	891.501.11	1-3/4 44.4	7/8 22.2	5/16 8	2-3/4	7/8
Super duty flush trim bit	806.690.11	3/4 19.05	2 50.8		4-1/8	3/4
Drawer front bit	837.955.11	2 50.8	1/2 12.7		2-13/32	1/2
Ogee door edge bit	859.564.11	1-1/2 38.1	3/4 19.05	1/4 6.35	2-5/8	1/2

Order No. 800.520.11 6 piece Ogee Cabinetmaking Set **1/2" shank**

Set contains	Order No. 1/2" shank	D_Cutting diameter inches mm	I_Cutting length inches mm	R_Cutting radius inches mm	L_Overall length inches	B_Bearing inches
Ogee raised panel w/back cutter	890.524.11	3-1/2 89	1-1/8 28.2	15/16 23.8	3-1/16	1-1/4 & 16mm
Ogee rail & stile bits	891.501.11	1-3/4 44.4	7/8 22.2	5/16 8	2-3/4	7/8
Super duty flush trim bit	806.690.11	3/4 19.05	2 50.8		4-1/8	3/4
Drawer front bit	837.955.11	2 50.8	1/2 12.7		2-13/32	1/2
Ogee door edge bit	859.564.11	1-1/2 38.1	3/4 19.05	1/4 6.35	2-5/8	1/2

Cove raised panel bit in 800.515.11

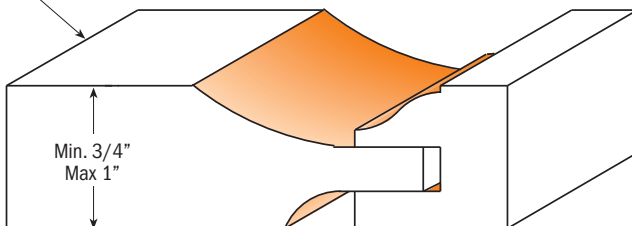

Ogee raised panel bit in 800.520.11

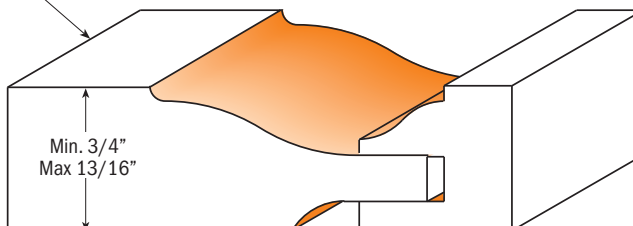

Drawings are 1:1 scale

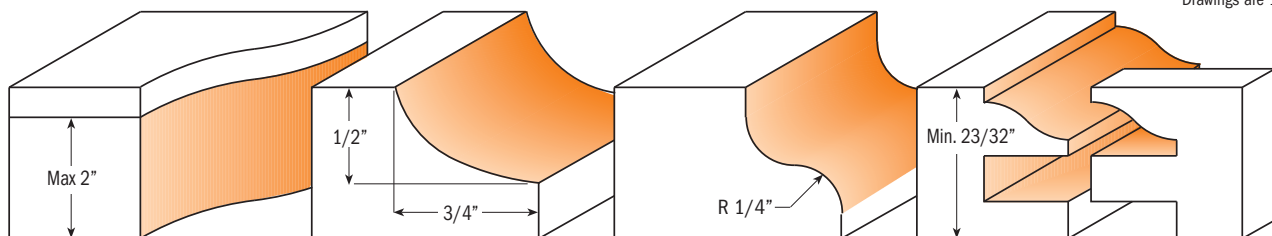

3 Piece Raise Panel Sets with Backcutter

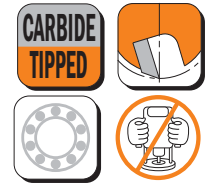
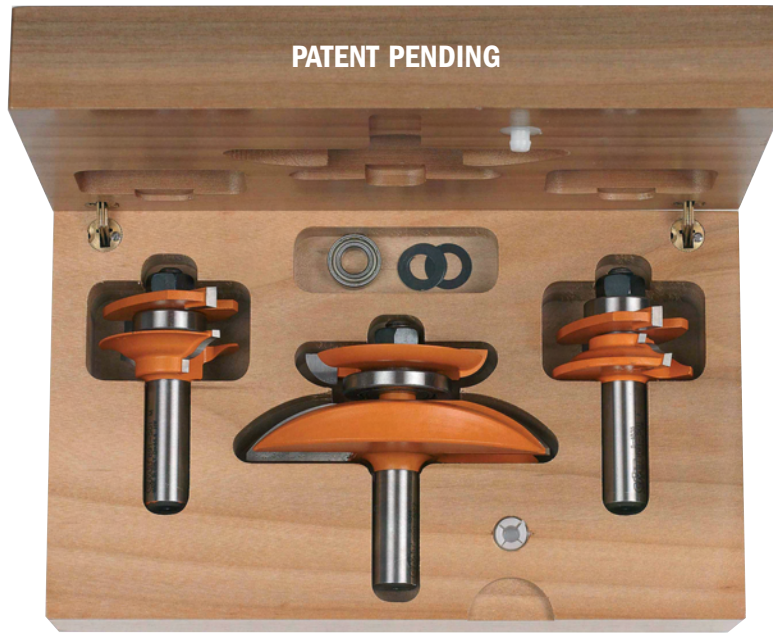

If your project calls for top quality raised panel doors, milled with accuracy and efficiency, then this set is a great choice. The ogee rail and stile bits are made to exact specifications to match perfectly, and the stile cutter is designed with a shear angle to produce superior cuts with minimal splintering. The raised panel bit is available with either cove or ogee profiles. Both bits include a back cutter which allows milling of the front and back of the panel in a single pass.

Order No. **800.517.11** 3 piece Cove Raised Panel Set **1/2" shank**

Set contains	Order No. 1/2" shank	D_Cutting diameter		I_Cutting length		R_Cutting radius		L_Overall length	B_Bearing
		inches	mm	inches	mm	inches	mm	inches	inches
Cove raised panel w/back cutter	890.527.11	3-1/2	89	1-1/8	28.6	1-1/2	38.1	3-1/16	1-1/4 & 16mm
Ogee rail & stile bits	891.501.11	1-3/4	44.4	7/8	22.2	5/16	8	2-3/4	7/8

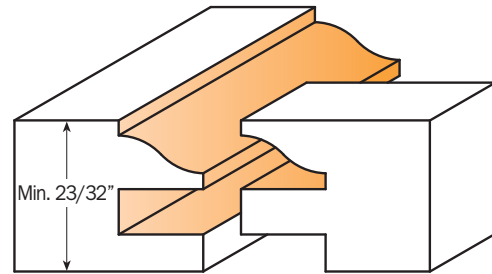
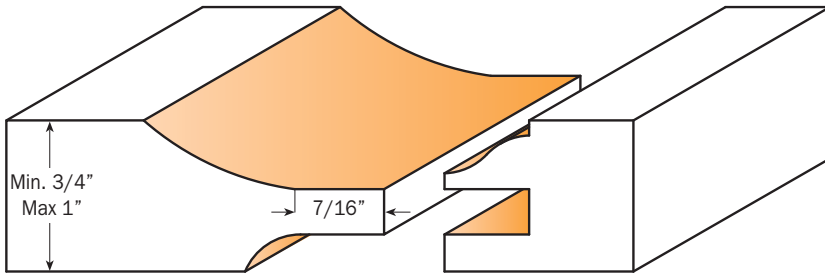

Drawings are 1:1 scale

Order No. **800.521.11** 3 piece Ogee Raised Panel Set **1/2" shank**

Set contains	Order No. 1/2" shank	D_Cutting diameter		I_Cutting length		R_Cutting radius		L_Overall length	B_Bearing
		inches	mm	inches	mm	inches	mm	inches	inches
Ogee raised panel w/back cutter	890.524.11	3-1/2	89	1-1/8	28.6	15/16	23.8	3-1/16	1-1/4 & 16mm
Ogee rail & stile bits	891.501.11	1-3/4	44.4	7/8	22.2	5/16	8	2-3/4	7/8

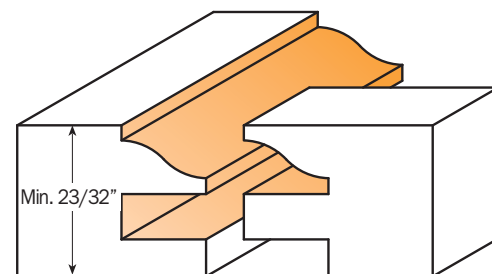
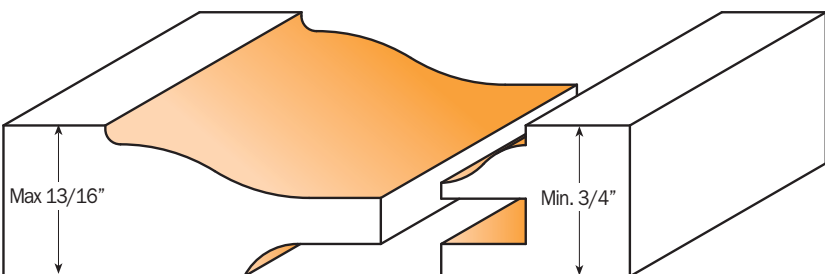

Drawings are 1:1 scale

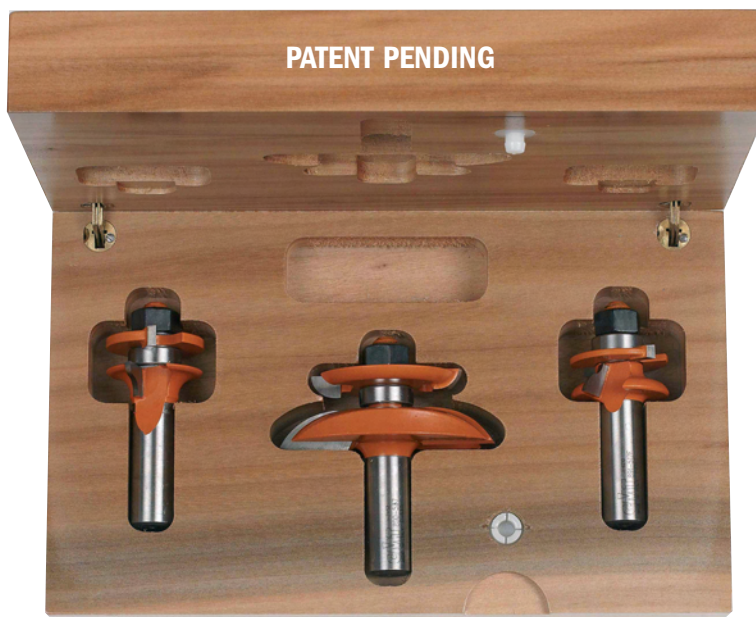

CMT's Junior Raised Panel Sets add intricate detail on a whole new scale! The Junior Raised Panel Set lets you make frame and panel details as small as 2-3/4" square in material as thin as 7/16". Delicate panel doors are only the beginning - use these bits with templates to add interesting arches to your work. The set includes your choice of a Cove or Ogee Raised Panel Bit and an Ogee Rail & Stile pair. Packaged in a beautiful hardwood case.

Order No. 800.518.11 3 piece Cove Junior Raised Panel Set **1/2" shank**

Set contains	Order No. 1/2" shank	D_Cutting diameter inches mm	I_Cutting length inches	R_Cutting radius inches	B_Bearing mm
Cove junior raised panel w/back cutter	890.537.11	2-1/2 63.5	11/16	3/4	16
Ogee junior rail & stile bits	891.517.11	1-1/4 31.7	11/16	1/8 - 3/16	16

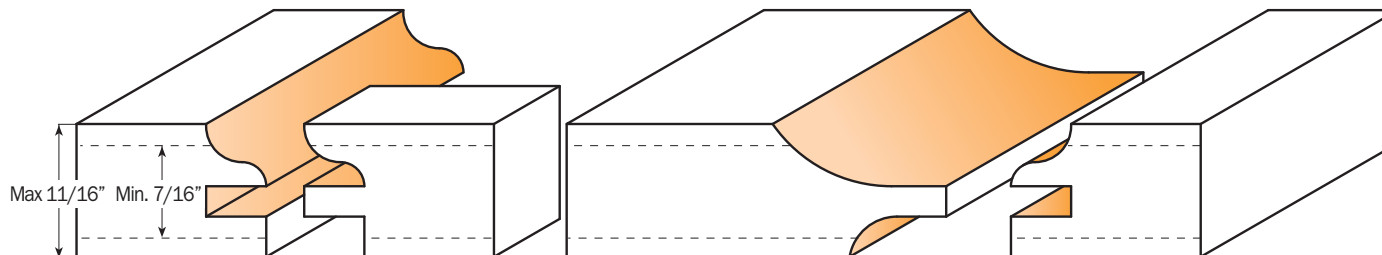

Drawings are 1:1 scale

Order No. 800.522.11 3 piece Ogee Junior Raised Panel Set **1/2" shank**

Set contains	Order No. 1/2" shank	D_Cutting diameter inches mm	I_Cutting length inches	R_Cutting radius inches	B_Bearing mm
Ogee junior raised panel w/back cutter	890.534.11	2-1/2 63.5	11/16	1/2	16
Ogee junior rail & stile bits	891.517.11	1-1/4 31.7	11/16	1/8 - 3/16	16

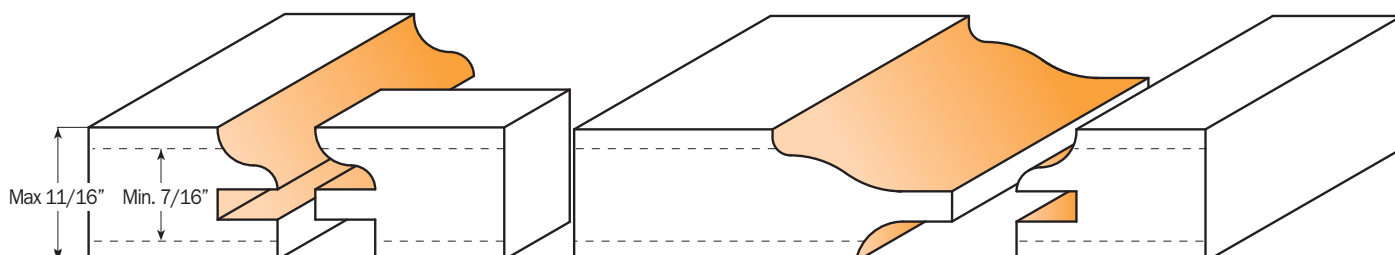

STEP 1. MAKING A SAMPLE DOOR

- A) This sample door size is 12" wide by 20" long.
- B) The door thickness should be 3/4" - 7/8"

STEP 2. DETERMINING THE SIZES OF EACH PART OF THE DOOR

- A) Always use a 1/2" overlay on all sides of the door.
- B) If the door opening is 11" wide by 19" high then the door size is 12" x 20".

IMPORTANT: Use 2-7/16" wide stiles so the templates will work properly.

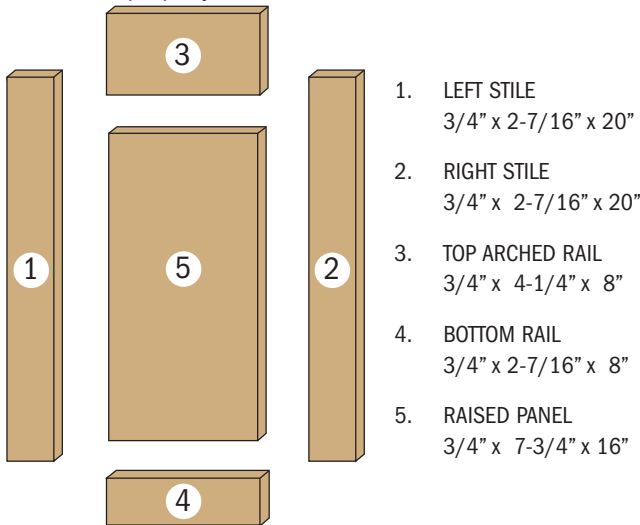

1-2. LEFT AND RIGHT STILES

- A) Always cut stiles 2-7/16" wide.
- B) Length of stiles is same as door length.

3. TOP ARCHED RAIL

- A) Cut 4-1/4" wide. Templates are 4" wide.
 - B) Length of rail is found by subtracting 4" from the total door width.
- (Overall door width is 12" minus 4" = 8" length of rail)

NOTE: This following procedure can only be used when using 2-7/16" wide stiles. Subtract 4" from the total door width instead of 4-7/8" since 7/16" in each stile will be taken up in the pattern cut.

4. BOTTOM RAIL

- A) Always cut 2-7/16" wide.
 - B) Length of rail is again found by subtracting 4" from the total door width.
- (Overall door width is 12" minus 4" = 8" for bottom rail lengths)

5. RAISED PANEL

- A) Width is always 1/4" less than rail length.
(1/8" space should be left on each side for expansion of panel)
- B) Rail length is 8" minus 1/4" = 7-3/4" width of raised panel.
- C) Length of raised panel is found by taking the overall door length and again subtracting 4".
(Overall door length is 20" minus 4" = 16" length of panel)

SUBTRACT 4" FROM THE OVERALL LENGTH OF THE DOOR. SUBTRACT 4" INSTEAD OF 4-7/8" SINCE THE PATTERN CUT TAKES UP 7/16" ON EACH RAIL.

At this time all 5 pieces of the door should be cut to the correct size.

STEP 3. CUTTING THE COPE CUTS ON EACH END OF THE 2 RAILS

- A) Cope cutter is the cutter with the bearing in the middle
- B) Set the cope cutter to the correct height in the router.
 - 1) The correct height is when, after the cut is made, the reveal on the front side should be 1/8" minimum (*Illustration 1*)
 - 2) Spaces A and B shown should be equal. If one is to be bigger, make B thicker for strength of panel.
- C) Set fence even with bearing.
- D) Use wooden pushblock to prevent tearout at end of cope cut.
- E) Run stock through with good side down at 14,000-16,000 RPMs.

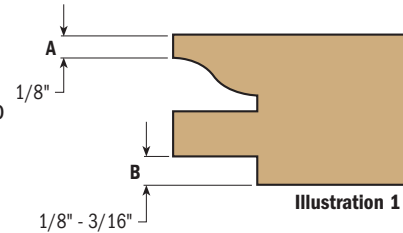

STEP 4. USING RAIL TEMPLATE TO FLUSH TRIM TOP RAIL TO CORRECT SHAPE

- A) Locate center of top rail with pencil on the back side.
- B) Pick out the correct template.

NOTE: THE SIZE ON THE TEMPLATE IS FOR THE OVERALL DOOR WIDTH. FOR THE TEMPLATES TO WORK PROPERLY STILES MUST BE MADE 2-7/16" WIDE. IF STILES ARE MADE IN DIFFERENT WIDTHS, ADJUSTMENTS IN PICKING OUT TEMPLATES MUST BE MADE.

- C) Line up template on back side of rail centering the notch of template with center line of rail. Now nail through the template into the 2 copes that were just cut (*Illustration 2*).

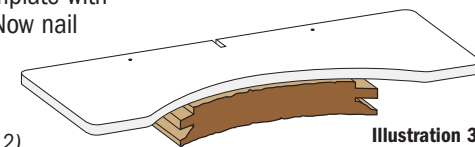
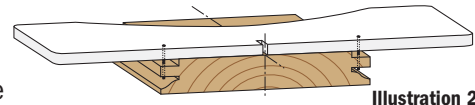

- D) Rough cut with jig or band saw within 1/8" or 1/4" of template (*Illustration 3*).

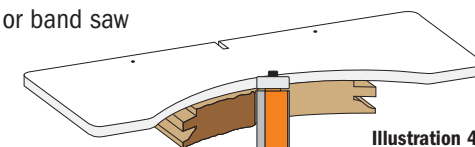

- E) Put flush trimming bit into router and set so bearing is flush with template (*Illustration 4*).

- F) Run router at 20,000-22,000 RPMs and flush trim top crown rail with good side down.

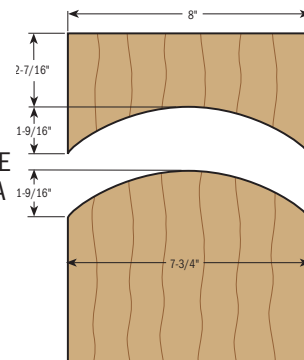

NOTE: WHEN STARTING CUT, ALWAYS REMEMBER TO MAKE CONTACT WITH BEARING TO A PLACE ON THE TEMPLATE WHERE THERE IS NO WOOD TO PREVENT KICKBACK.

- G) Slow down at end of cut to prevent tearout. Leave template attached to rail for now.

STEP 5. USING PANEL TEMPLATE TO FLUSH TRIM THE RAISED PANEL TO SHAPE

- A) Locate center of raised panel on front side.
- B) Pick out correct template (same size as rail template).
- C) Line up center notch of template with center line of panel and make sure it is also square (*Illustration 5*).
- D) Nail template to panel about 1/2" in from each side (*Illustration 5*).

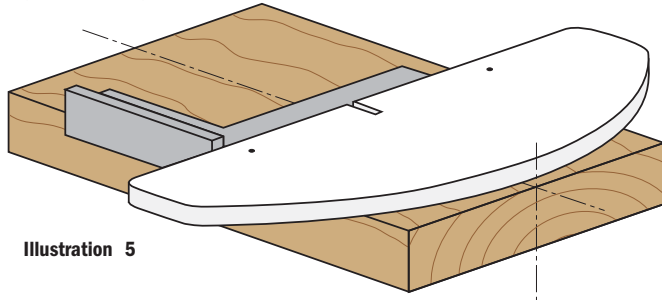

Illustration 5

NOTE: DRIVE NAILS IN ABOUT 1/4"-3/8". THE NAIL HOLES WILL BE MACHINED OUT WHEN RAISED PANEL CUT IS MADE.

- E) Rough cut stock to within 1/8" - 1/4" of template.
- F) Flush trim raised panel in the same manner as you did the top rail with the template on top (*Back to illustration 4*).

NOTE: AGAIN MAKE SURE BEARING COMES IN CONTACT WITH TEMPLATE FIRST AND THEN GUIDE INTO THE WOOD.

- G) Pull nails out after flush trimmed.

STEP 6. CUTTING FREEHAND PATTERN CUT ON TOP ARCHED RAIL

- A) Pattern cutter is the cutter with the bearing on top.
- B) Insert pattern cutting bit to correct height to match cope cut. This can be done by making a few practice cuts in scrap wood.
- C) Run router at 14,000-16,000 RPMs.
- D) Start cut with bearing making contact with template only and ease into cut. No fence is used. (*Illustration 6*).
- E) Slow down at end of cut to prevent any chipout.
- F) Remove template from top arched rail.

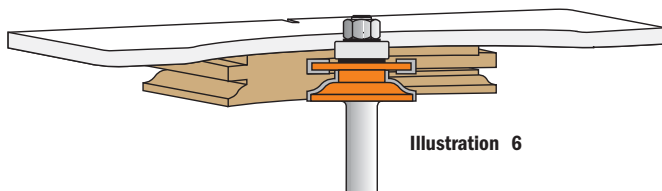

Illustration 6

STEP 7. CUTTING THE STRAIGHT BOTTOM RAIL AND 2 STILES

- A) Insert fence and line up fence with bearing on the same pattern cutter.
- B) Run router 14,000-16,000 RPMs
- C) Use push-block and push bottom rail through with good side down.

STEP 8. MAKING RAISED PANEL CUT

- A) Insert panel cutter to correct height.

NOTE: IT MAY TAKE A COUPLE OF PRACTICE CUTS IN SCRAP WOOD BEFORE GETTING THE PANEL FLUSH WITH PATTERN CUT.

- B) Set fence so it is even with bearing on panel cutter.
- C) Run router slow 10,000 RPMs. ALWAYS USE PUSH BLOCKS FOR SAFETY.
- D) Make first cut across the grain with good side face down.
- E) Cut with the grain on left side.
- F) Remove fence and use a half-fence. (*Illustration 7*)
- G) Start by re-doing left side and come around and cut the curved top of the panel freehand.
- H) Install full fence and complete right side.

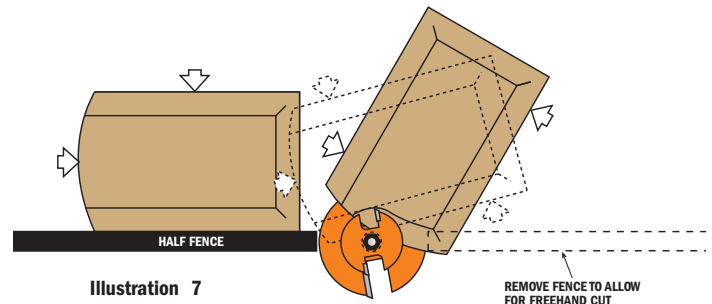
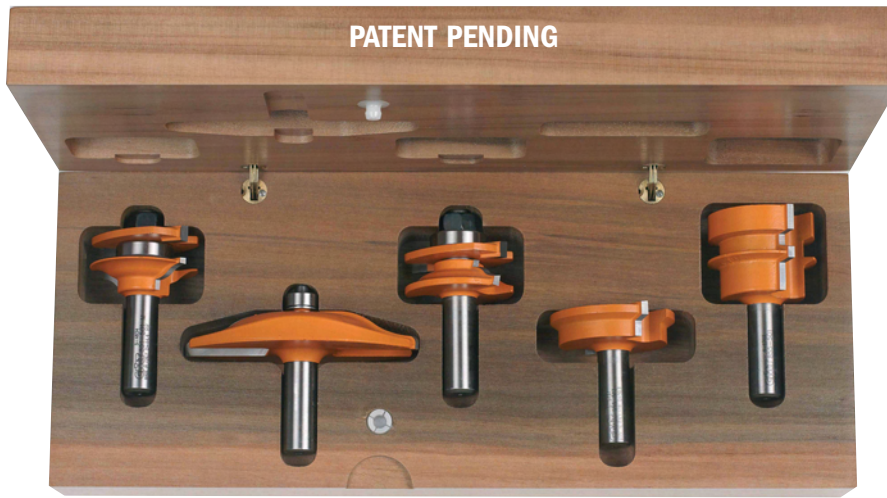

Illustration 7

REMOVE FENCE TO ALLOW FOR FREEHAND CUT

5 piece Complete Kitchen Sets



Set contains	Order No. 1/2" shank	D_Cutting diameter inches mm	I_Cutting length inches mm	T_Stock thickness inches	L_Overall length inches	B_Bearing inches
Order No. 800.509.11 Ogee Complete Kitchen Set						
Ogee raised panel bit	890.501.11	3-1/4 82.5	19/32 15	19/32 to 23/32	2-1/2	1/2
Ogee rail & stile bits	891.501.11	1-3/4 44.4		23/32 to 7/8	2-51/64	22mm
Reverse glue joint bit	855.501.11	1-3/4 44.4	1-1/4 31.7	19/32 to 1-3/16	2-3/4	
Drawer lock bit	855.502.11	2 50.8	1/2 12.7		2	
Order No. 800.510.11 Standard Complete Kitchen Set						
Standard raised panel bit	890.502.11	3-1/4 82.5	19/32 15	19/32 to 23/32	2-1/2	1/2
Standard rail & stile bits	891.502.11	1-3/4 44.4		23/32 to 7/8	2-51/64	22mm
Reverse glue joint bit	855.501.11	1-3/4 44.4	1-1/4 31.7	19/32 to 1-3/16	2-3/4	
Drawer lock bit	855.502.11	2 50.8	1/2 12.7		2	
Order No. 800.511.11 Bevel & Radius Complete Kitchen Set						
Bevel & radius raised panel bit	890.503.11	3-1/4 82.5	19/32 15	19/32 to 23/32	2-1/2	1/2
Bevel & radius rail & stile bits	891.503.11	1-3/4 44.4		23/32 to 7/8	2-51/64	22mm
Reverse glue joint bit	855.501.11	1-3/4 44.4	1-1/4 31.7	19/32 to 1-3/16	2-3/4	
Drawer lock bit	855.502.11	2 50.8	1/2 12.7		2	

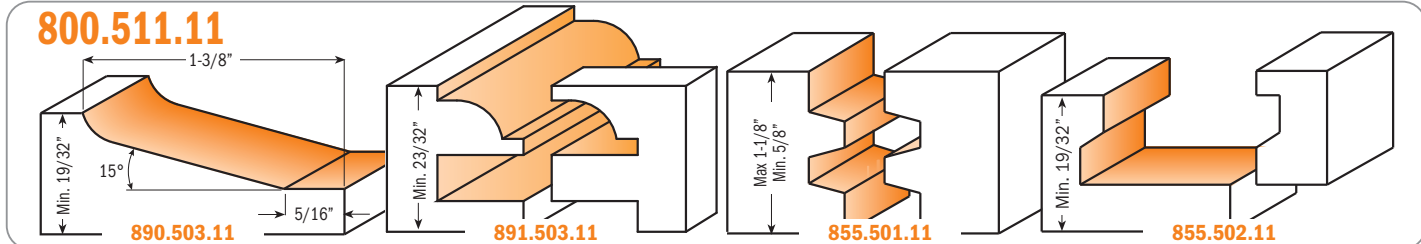
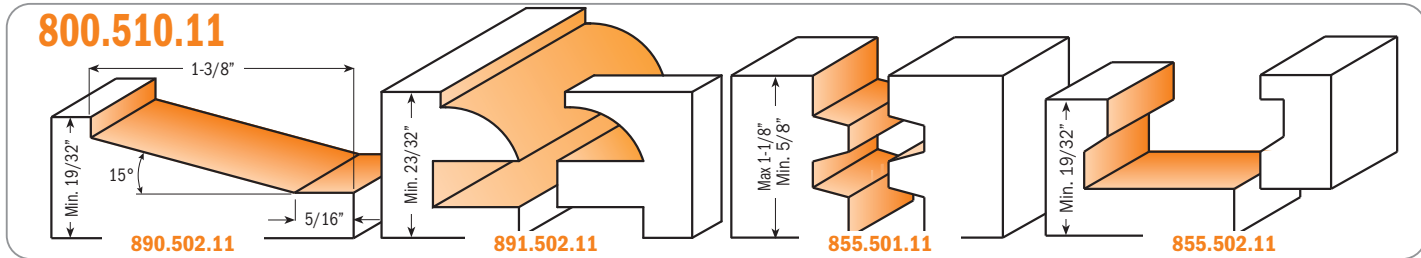
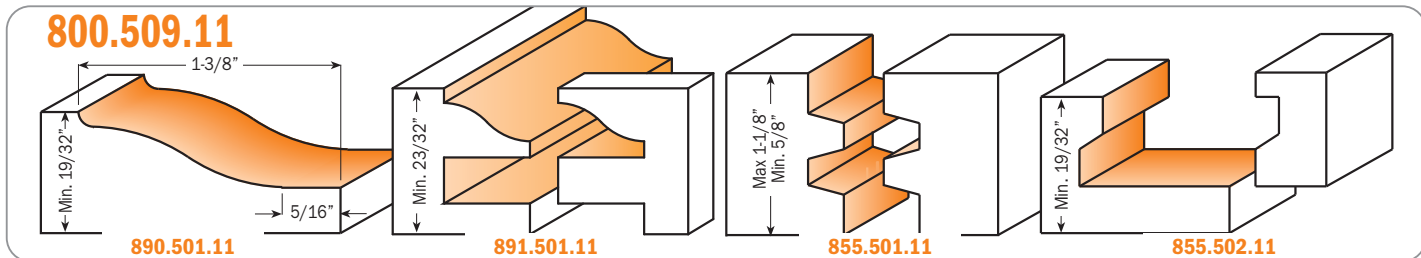

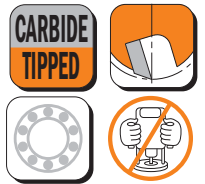
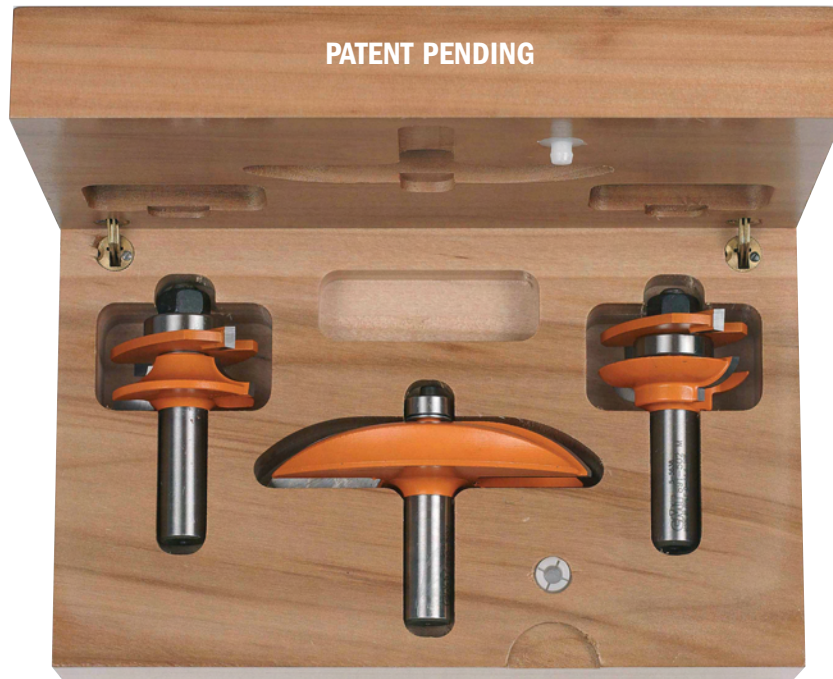

Set contains	Order No. 1/2" shank	D_Cutting diameter inches mm	I_Cutting length inches mm	T_Stock thickness inches	L_Overall length inches	B_Bearing inches
Order No. 800.513.11 Ogee Kitchen Set						
Ogee raised panel bit	890.504.11	3-1/4 82.5	19/32 15	23/32 to 25/32	2-1/2	1/2
Ogee rail & stile bits	891.501.11	1-3/4 44.4	19/32 15	23/32 to 7/8	2-51/64	22mm
Order No. 800.512.11 Standard Kitchen Set						
Standard raised panel bit	890.505.11	3-1/2 88.9	19/32 15	23/32 to 25/32	2-1/2	1/2
Standard rail & stile bits	891.502.11	1-3/4 44.4	19/32 15	23/32 to 7/8	2-51/64	22mm
Order No. 800.514.11 Bevel & Radius Kitchen Set						
Bevel & radius raised panel bit	890.506.11	3-1/2 88.9	19/32 15	23/32 to 25/32	2-1/2	1/2
Bevel & radius rail & stile bits	891.503.11	1-3/4 44.4	19/32 15	23/32 to 7/8	2-51/64	22mm
Order No. 800.516.11 Cove Kitchen Set						
Cove raised panel bit	890.507.11	3-1/2 88.9	19/32 15	23/32 to 25/32	2-1/2	1/2
Standard rail & stile bits	891.502.11	1-3/4 44.4	19/32 15	23/32 to 7/8	2-51/64	22mm

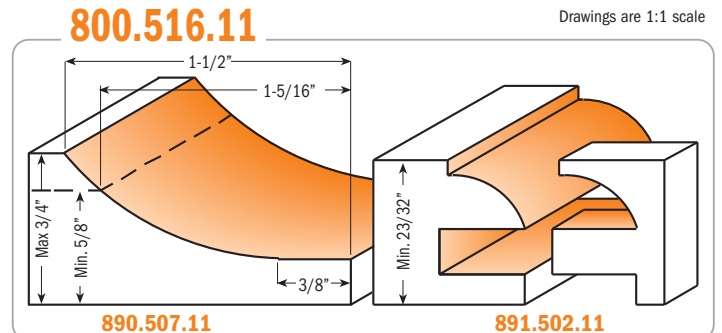
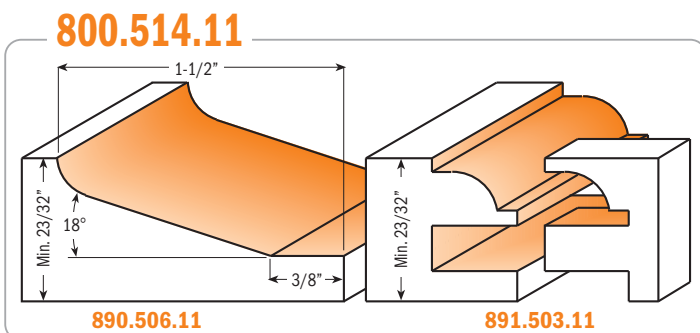
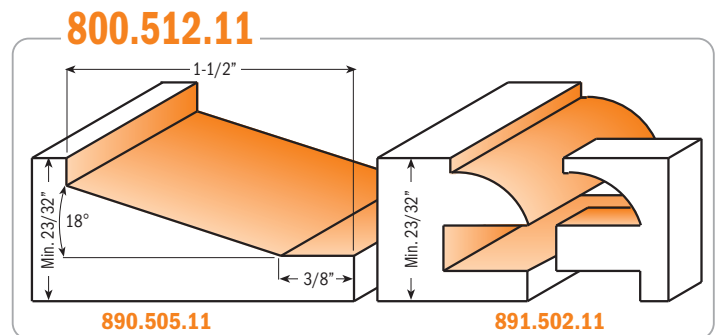
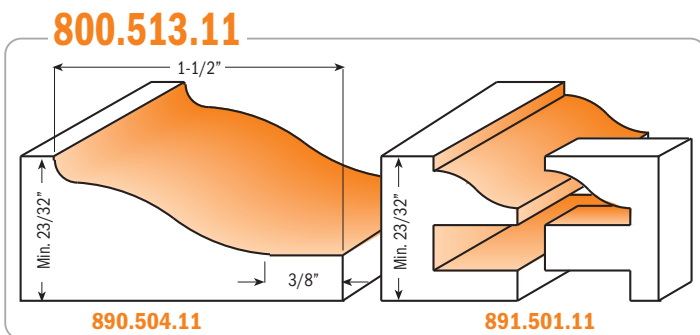

Drawings are 1:1 scale

Step-By-Step Raised Panel Door Construction

Use these instructions with any of CMT's Kitchen Sets, or with the Raised Panel or Rail and Stile Sets sold individually on **pages 57 through 59**.

In our step by step example of panel door construction, we used the following:

- CMT Rail & Stile set (item # 891.502.11)
- Raised panel bit (item # 890.502.11)
- CMT Reverse Glue Joint (item #855.501.11)
- pre-cut stiles - 3/4" thick x 2-7/16" wide
- pre-cut rails - 3/4" thick x 2-7/16" wide
- panel - 3/4" thick
- scrap stock

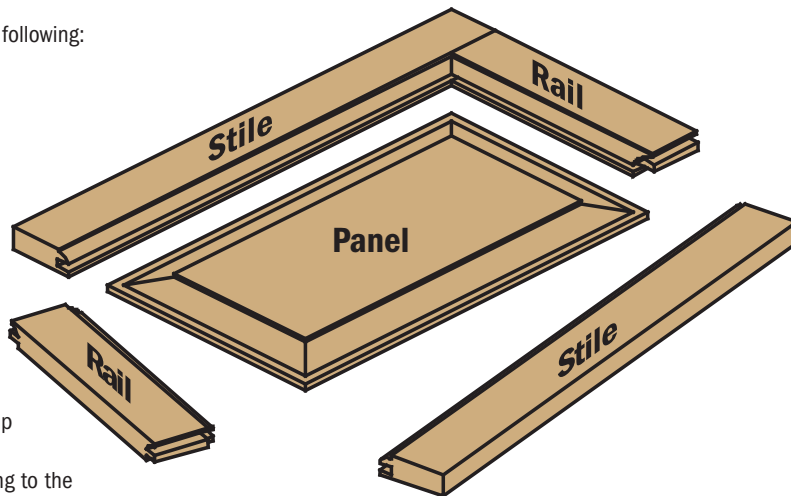

The CMT Rail & Stile set was designed ideally for the construction of panel doors from 3/4" thick stock, however any variation of size up to 7/8" thick can be used.

Remember to adjust your measurements and cutting depths according to the wood thickness you use.

MILLING THE RAILS AND STILES

First make trial cuts of the cope profile (rail) and the stick profile (stile) in scrap stock and check the accuracy of the joint. This is extremely important when working at maximum thickness (7/8"). Make sure your stock is flat and cut straight with square edges. Using the CMT Stile Bit shown in Illustration 1, place the stock front face side down on the router table and mill the stick profile in the stile and rail pieces. To mill the cope cuts, use the CMT Cope Bit shown in Illustration 2, position the rails face side down on the router table and mill the cope profile in the ends. If you are milling cope and stick profiles before cutting the rails and stiles to length, make sure to make the proper calculations before cutting the rails. The stiles are the same length as the door. The length of the rails must be calculated by the following equation:

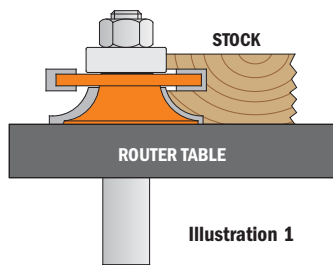

Illustration 1

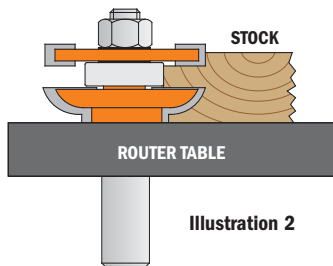

Illustration 2

Width of the door, minus the width of the two stiles, plus the length of the two tenons, equals rail length.

In our example, the door is 12" wide, and the stiles are both 2-7/16" wide.

The tenons produced by CMT rail and stile bits are 7/16" long. Therefore, the equation for our examples is: **12" - 4-7/8" + 7/8" = 8" rail length**

GLUEING UP PANELS

If the panel requires a width greater than the width of your stock, you will need to edge-gue stock for the central floating panel. This is simply accomplished using the CMT Reverse Glue Joint bit. Place the first panel front-face down on the router table and accurately center the wood to the bit. Adjust the bit according to the thickness of the wood you are cutting by lining up the cut edge of the wood to the center point of the bit as illustrated in Illustration 3 and mill the cut edge of the wood. Place the second panel front face up and repeat the milling process. This assures you will have the best side of your stock as a front

face. If a third panel is required, mill one cut edge of the piece as instructed above, turn the piece over and run the other edge. Assemble the reverse cut pairs together for beautiful, strong joints that match up perfectly.

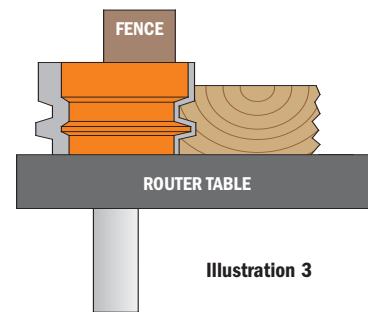

Illustration 3

MILLING THE FLOATIN PANEL

Make trial cuts in scrap stock so the top of the panel is flush with the top of the rail and stile pieces. The panel size can be calculated using this method: the width of the panel is 1/4" less than the length of the rail. If the rail length is 8", the panel width is 7-3/4". This allows the panel to expand and contract between high and low humidity seasons. It is also advisable to insert Panalign strips which keep the panels centered. The length of the panel is 4" less than the overall door length. A 24" long cabinet door - 4" = 20" long raised panel. This 4" method only works when you make your rails and stiles 2-7/16" wide since our tenons are cut 7/16" long.

If you plan on using the Panalign strips on the top and the bottom of the panels, you should subtract another 1/4" on the length of the panel. It is not required to use Panalign strips on the top and bottom, but some cabinetmakers use them to expose more of the raised panel cut.

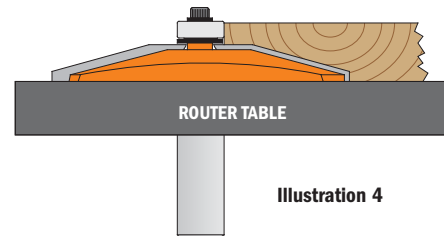
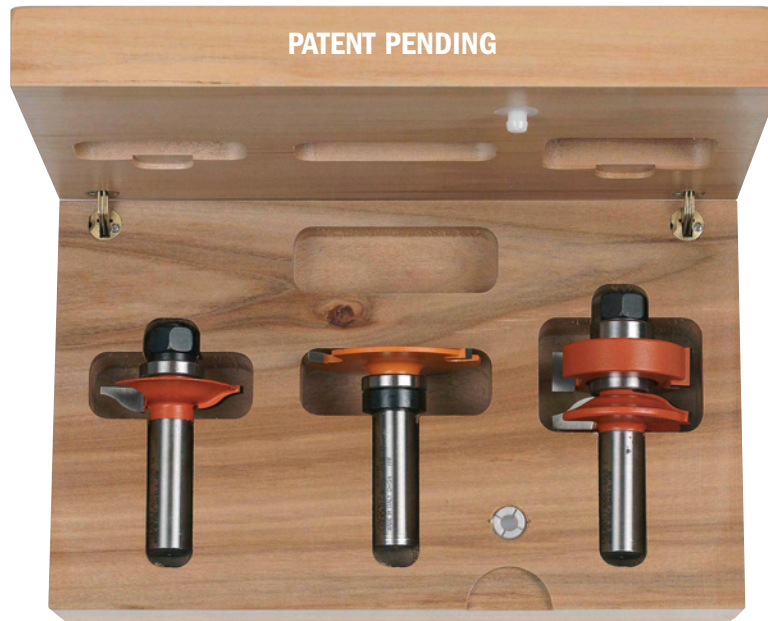

Illustration 4

Safety Precautions:

- ◆ This bit is capable of removing large amounts of stock. To safely and effectively produce the profile you want, we suggest making several shallow passes by moving the fence. It is dangerous to try to mill the entire profile in one single pass.



CMT's unique stile and rail set allows you to produce glass panel doors utilizing a rubber panel retainer to secure the glass in a 1/8" slot cut into the frames. These 1/2" shank bits work the same as our other stile and rail sets, but leave you with a square rabbet on the inside of your door for installing the glass panel.

Order No. 855.803.11 3 piece Glass Panel Set **1/2" shank**

Set contains	Order No. 1/2" shank	D_Cutting diameter		L_Cutting length		R_Cutting radius		L_Overall length	B_Bearing
		inches	mm	inches	mm	inches	mm	inches	inches
Ogee Rail & Stile set	855.803.11MF	1-5/8	41.2	13/16	20.6	5/16	8	3-1/32	3/4
1/8" Slot Cutter	822.016.11B	2-1/8	53.9	1/8	3.17			2-13/64	3/4

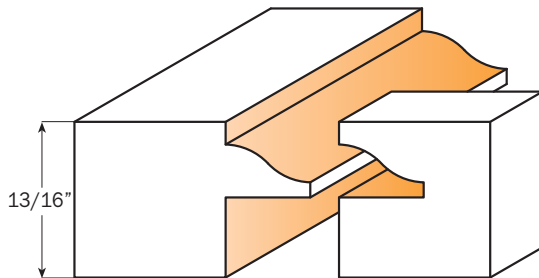

Drawings are 1:1 scale

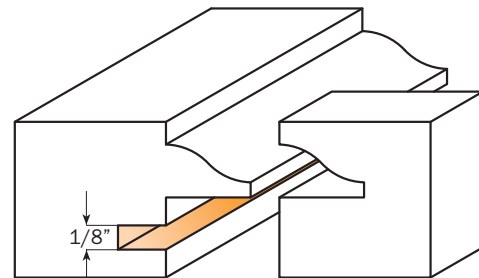

Here's how it works:

Mill the cope and pattern cuts first, then use the slot cutter to cut the groove for the rubber panel retainer. The edge of the pattern cut will ride on the bearing of the slot cutter bit. When you cut the slot in the rails you can cut the slot the full length of the stock. When you cut the slot in the stiles you need to set up reference points to stop and start the cuts so they are hidden from view on the top and bottom of the doors.

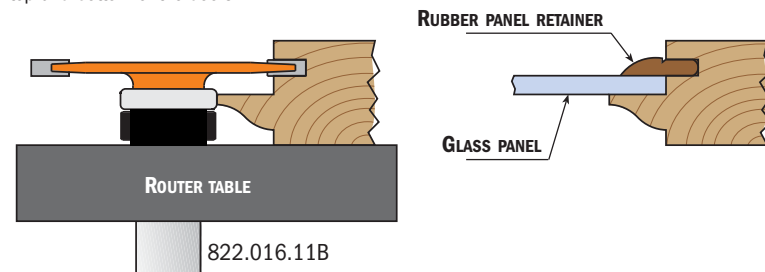

Glass Panel Retainers

Order No. **GLAS/RTBRN** 25' roll

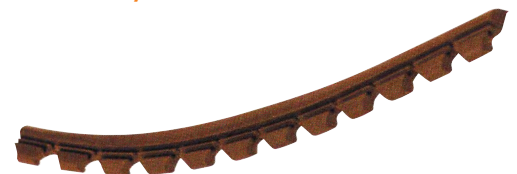

Our unique retainer strips fit perfectly in the 1/8" slot created by the slot cutter bit, and hold your glass securely in the frame. Sold in 25' lengths.

3 piece Lonnie Bird's Divided Light Door Set

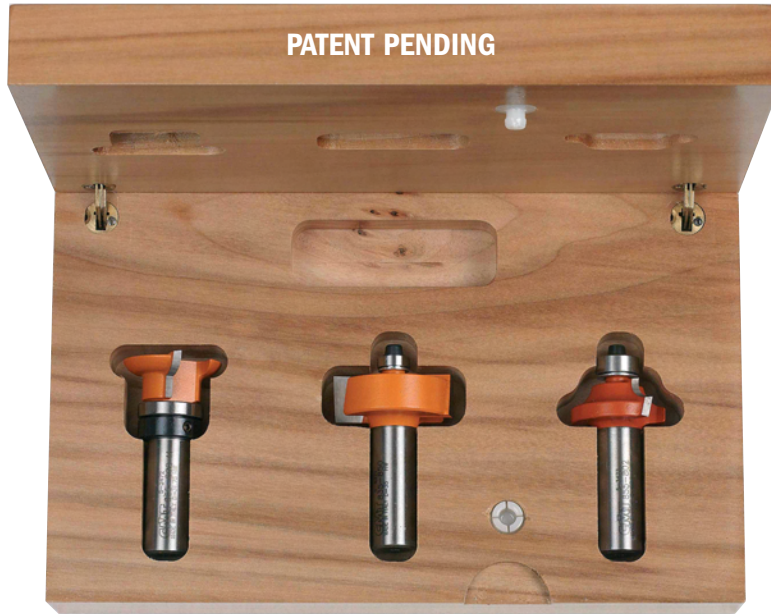

Build authentic divided light doors for fine furniture and cabinets with this 3-piece set. The set includes a stick bit to cut the decorative ovolo profile on the frame edges, a cope bit which shapes the mating profile on the ends of the stock, and a rabbeting bit for cutting the recess for the glass. Because the bits have guide bearings you can also create arched or curved frames.

The unique design of the cope bit allows you to use full-length tenons to create strong, authentic mortise-and-tenon joinery. As the stock is coped, the tenon passes over the bit. The set is designed for 7/8" wide bars such as those on a corner cupboard door. Instructions included.

Note: You will need to produce mortise and tenon joints with a tenoning jig or other tools.

Order No. **800.525.11** 3 piece Lonnie Bird's Divided Light Door Set **1/2" shank**

Set contains	Order No. 1/2" shank	D_Cutting diameter		I_Cutting length		R_Cutting radius		H_Cutting depth		B_Bearing
		inches	mm	inches	mm	inches	mm	inches	mm	inches
Rabbeting bit	835.850.11	1-3/8	34.9	1/2	12.7			3/8	9.5	3/8
Rail & stile bits	855.802.11	1-1/4	31.7	1/2	12.7	1/4	6.35			1/2 & 3/4

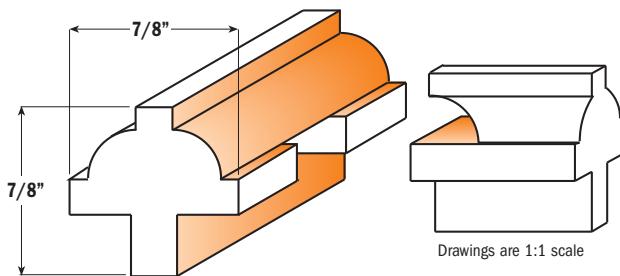

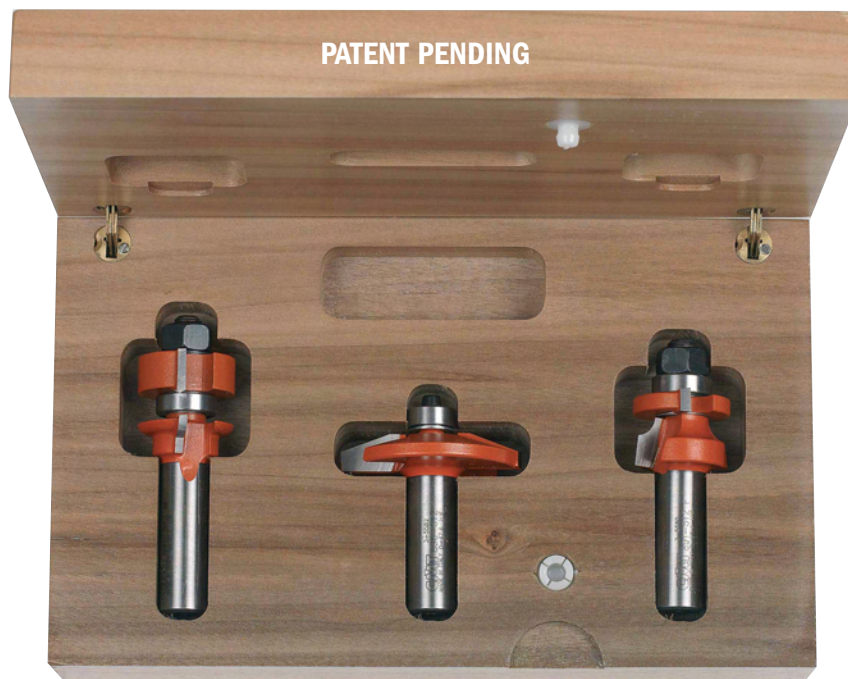

This three-piece set will produce beautiful raised panel doors with a classic, diminutive beveled profile. Designed for use in fine furniture making, the set includes two matched cope and stick bits for producing frames in 5/8" to 3/4" thick material. The stick bit shapes a decorative 3/16" thumbnail molding along the edge of the frame. The panel bit is designed for 1/2" thick material. All bits are equipped with guide bearings for shaping curved work such as the small arched panel doors seen on secretaries and corner cabinetry. This set also produces panels for small chests, lids for small boxes, or drawer fronts. Instructions included.

Order No. **800.524.11** 3 piece Lonnie Bird's Small Arch Door Set **1/2" shank**

Set contains	Order No. 1/2" shank	D_Cutting diameter		L_Cutting length		T_Stock thickness	I_Overall length	B_Bearing
		inches	mm	inches	mm	inches	inches	inches
Small standard raised panel bit	890.512.11	1-7/8	47.6	3/8	9.5	1/2 to 19/32	2-9/32	1/2
Small standard rail & stile bits	891.512.11	1-1/8	28.7			5/8 to 7/8	3-1/8	16mm

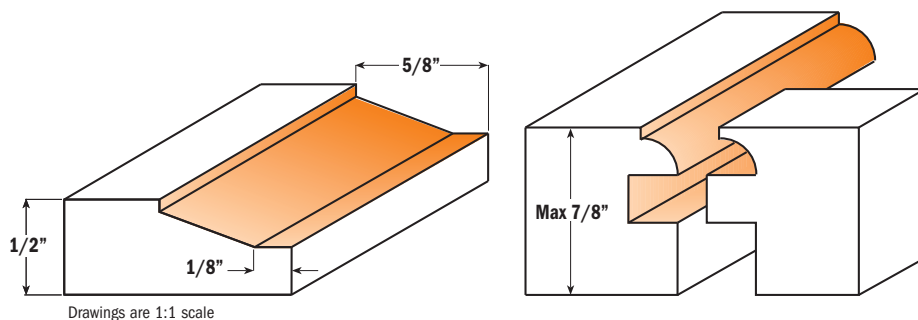

7 piece Lonnie Bird's Crown Molding Set

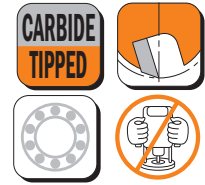

Order No. **800.523.11** 7 piece Lonnie Bird's Crown Molding Set

1/2" shank - 5/8" arbor

Set contains	Order No. 1/2" shank
Inverted roman ogee profile - 5/32" radius	867.501.11B
Inverted roman ogee profile - 5/32" radius	867.502.11B
Inverted roman ogee profile - 1/4" radius	867.503.11B
Inverted roundover profile - 1/4" radius	867.601.11B
Inverted roundover profile - 5/16" radius	867.602.11B
Inverted roundover profile - 3/8" radius	867.603.11B
Cove cutter head - 7" diameter, 5/8" arbor, 6 carbide teeth	235.006.07
Shim, 5/8" bore	299.011.00

This set lets you make crown molding that surpasses anything you'll find at the lumberyard, and crown molding is just the beginning! By arranging the profiles of the six router bits in various combinations you can create dozens - or hundreds - of different decorative profiles!

The set consists of a 7" diameter, 5/8" arbor cove cutter for your table saw, and six 1/2" shank carbide tipped router bits. All six bits - three ogees and three roundovers - feature CMT's unique inverted design. Why use inverted profiles? Because the flat face of your workpiece always remains in firm contact with your router table for unprecedented accuracy and control.

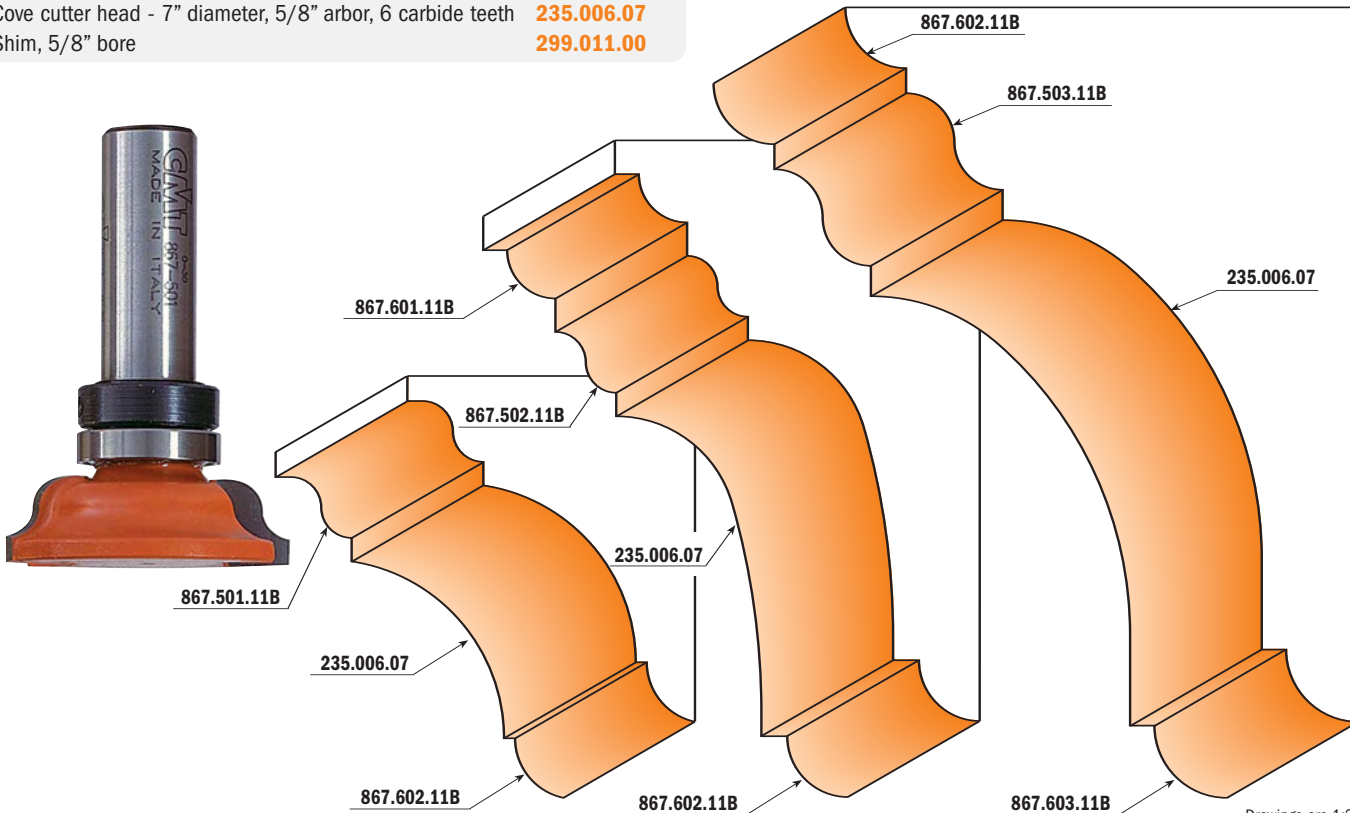

Drawings are 1:2 scale

Creating molding with CMT's Crown Molding Set

CMT's Lonnie Bird Crown Molding Set allows you to shape elegant moldings with your tablesaw and router table. The set consists of a cove cutter and six router bits with inverted profiles. The cove cutter mounts on your tablesaw and is used in conjunction with a pair of angled fences. Changing the fence angle and cutter height allows you to create an almost infinite variety of cove shapes and sizes. After milling the cove, you can use the special router bits with inverted profiles to complete the molding.

PLAN YOUR CUTS

Begin with a drawing of your design or use one of the designs shown below. Next, sketch the cove outline on each end of the stock as shown at right.

PREPARE THE STOCK

In order to get the best possible yield from your stock, we suggest that you rip the stock diagonally on a bandsaw before milling the cove as shown in Illustration 1.

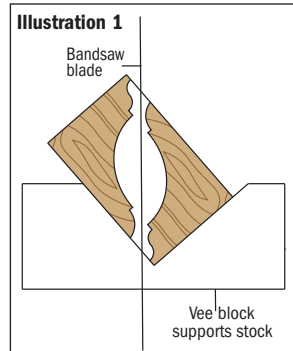

MOUNTING THE CUTTERHEAD

Begin by disconnecting the tablesaw from its power source and removing the blade. To mount the cutterhead, first position the 2-5/8" diameter spacer that came with the set against the flange on the saw arbor. The spacer will center the cutterhead within the throat plate opening. Next, position the cutterhead on the arbor and secure the assembly with the washer and arbor nut. Finally, place the dado throat plate in position. Before turning on the power, rotate the cutterhead by hand to be certain that it clears the throat plate.

MILLING COVES

This process is very similar to cutting coves with a standard saw blade on a table saw. *If this operation is new to you or if you have questions beyond the instructions, we highly recommend you take time to further study this technique in either a woodworking class or a woodworking book that teaches the safest way to perform this operation.*

Always make your molding by milling the cove first while the stock has the greatest mass. To safely use the cove cutter, it's necessary to have a dado head insert plate for your saw. Use a dual fence set up as shown in Illustrations 2 & 3 to guide and support the workpiece as the cove is shaped. The fences are clamped to the top of the tablesaw and the stock passes between them, running at an angle to the cutting blade. With the cutterhead height set at the depth of the cove to be cut, position a fence at an angle so that the stock enters the cutter along the left leading edge and exits the stock along the right trailing edge.

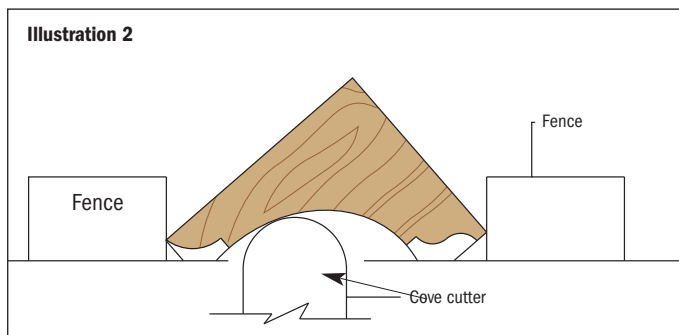

Before making the first cut, lower the cutterhead to 1/16" above the table top. Turn on the power and feed the stock slowly between the fences; after each pass raise the cutterhead another 1/16". **Remember to use a guard and push blocks** for added safety.

Illustration 3: Creating different coves with different fence angles

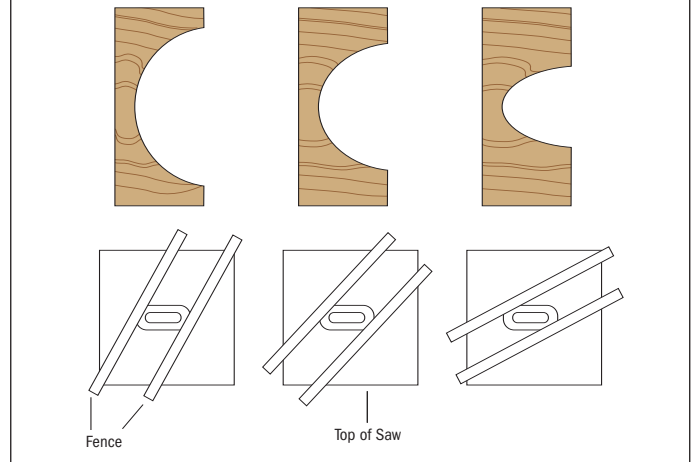

ROUTING MOLDINGS WITH THE INVERTED BITS

Because the profiles are inverted on the shank, you can rout large moldings that are impossible to shape with ordinary router bits.

Before routing, always begin with a drawing of the molding that you would like to produce. Remember, begin by shaping the cove with the cove cutter on your tablesaw, then set up the routing tasks.

Afterwards, rout the profiles that flank each side of the cove. Use your router table and a fence for the best support of the stock.

For added safety and the smoothest possible surface, always take multiple light cuts and support the workpiece with featherboards.

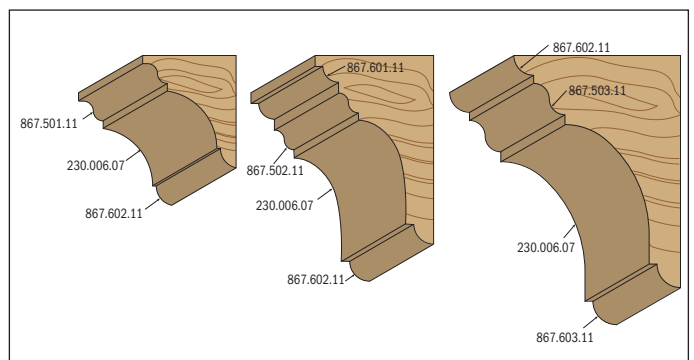

MILLING CURVED MOLDINGS

The inverted router bits each have a bearing mounted on the shank. This feature allows you to shape curved profiles such as gooseneck and circular moldings. When routing curved moldings, first attach a plywood template to the workpiece to serve as a guide for the bearing to ride on.

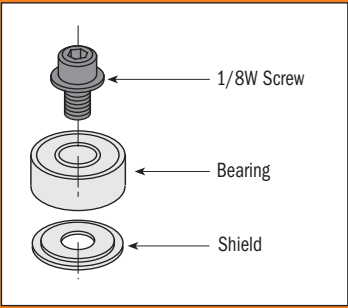

* **BE SURE:** to keep the black washer right side up to correspond with the bearing rotation during reassembly.

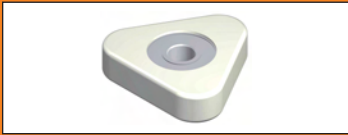

* **10° Delrin® conical bearing**
 ** **Delrin® triangular bearing**

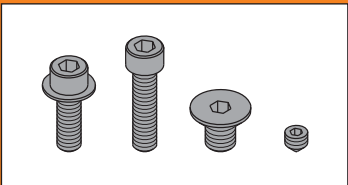
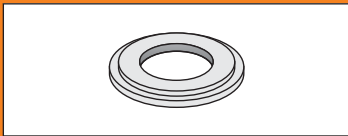

791 Top-Quality bearing

Order No.	D_Cutting diameter inches	D_Cutting diameter mm	d_Small diameter inches	d_Small diameter mm	Thickness mm
791.035.00	1/4	6.35	1/8	3.17	3.2
791.002.00	3/8	9.5	3/16	4.76	3.2
791.003.00	1/2	12.7	3/16	4.76	5
791.010.00	1/2	12.7	1/4	6.35	4.8
791.022.00		13		5	4
791.023.00		13		6	5
791.024.00		15		6	5
791.018.00	5/8	15.8	3/16	4.76	5
791.009.00	5/8	15.8	1/4	6.35	5
791.006.00		16		5	5
791.025.00		16		8	5
791.019.00	3/4	19	3/16	4.76	7.5
791.007.00		19		6	6
791.004.00	3/4	19	1/4	6.35	7
791.034.00		19		8	6
791.011.00	3/4	19	1/2	12.7	4
791.012.00		22		8	6
791.005.00		22		8	7
791.017.00	7/8	22.2	3/16	4.76	7.5
791.021.00	7/8	22.2	3/8	9.52	7
791.013.00	7/8	22.2	1/2	12.7	4
791.036.00		24		8	8
791.026.00		28		12	8
791.014.00	1-1/8	28.5	3/16	4.76	8.4
791.027.00	1-1/8	28.5	1/2	12.7	8
791.030.00	1-1/8	28.5		8	8.5
791.033.00	1-1/4	31.7		8	5
791.015.00	1-1/4	31.7	1/2	12.7	10
791.016.00	1-3/8	34.9	3/16	4.76	11.5
791.029.00	1-3/8	34.9	1/2	12.7	11
791.031.00	1-3/8	34.9		8	11.6
791.028.00		37		12	12
791.020.00	1-1/2	38.1	1/2	12.7	13.3
791.041.00*	3/4	19	3/16	4.76	6.8
791.042.00**	1/2	12.7	3/16	4,76	5.8
791.043.00**	3/4	19	3/16	4,76	7

799 Reduction bushing for bearing

Order No.	d_Small diameter inches	D_Cutting diameter inches
799.014.00	3/16	1/2
799.019.00	3/16	1/4
799.017.00	3/16	8mm

990.4 Shields for bearing

Order No.	Description
990.422.00	Shield for 3/8" bearing
990.423.00	Shield for 1/2" bearing

990 Screws for bearing

Order No.	Description
990.058.00	Screw 1/8W x 3/8"
990.059.00	Screw 1/8W x 1/2"
990.004.00	Screw M4x6mm
990.005.00	Screw for stop collar M3x3mm
990.055.00	Screw for stop collar M5x12mm

991 Hex key for bearing screws

Order No.	Description
991.057.00	3/32" hex key for 1/8" screw
991.062.00	2.5mm hex key for M4 screw
991.056.00	1.5mm hex key
991.060.00	2mm hex key
991.067.00	3mm hex key

541 Stop collar for top bearing bits

Order No.	Description
541.001.00	Stop collar for 1/4" shanks
541.002.00	Stop collar for 1/2" shanks
541.006.00	Stop collar for 3/8" shanks

541 Spacer/Shims

Order No.	d_Inside diameter mm	D_Outside diameter mm	Thickness mm
541.550.00	3.25	9	1.6
541.552.00	3.25	15.8	2
541.551.00	5.2	15.8	2.5
541.514.00	6.4	9.52	2.2
541.515.00	8	14	0.1
541.516.00	8	14	0.3
541.517.00	8	14	0.5
541.518.00	8	14	1
541.500.00	8	14.7	3
541.501.00	8	14.7	4
541.519.00	8	14.7	5.8
541.512.00	12	20	2
541.511.00	12	20	3
541.513.00	12	21	0.1
541.520.00	12	21	0.3
541.521.00	12	21	1.59
541.522.00	12	21	3.18
541.523.00	12	21	6.16
541.524.00	12	21	1
541.525.00	12	21	0.5

799 Bushings

Order No.	d_Inside diameter inches	d_Inside diameter mm	D_Outside diameter inches	D_Outside diameter mm	L_Overall length inches
799.064.00	1/4	6.35	8	8	25
799.164.00	1/4	6.35	3/8	9.5	25
799.264.00	1/4	6.35	1/2	12.7	25
799.001.00	3/8	9.5	1/2	12.7	25

990 Nuts

Order No.	Description
990.020.00	Nut for arbor M8 thread
990.022.00	Nut for arbor M12x1.25 thread

796 Collet chuck

Order No.	Description
796.001.00	Router collet extension 1/2"
796.000.00	Collet chuck 1/4" - 3/8" w/out collet
796.121.00	Collet chuck 1/2" w/out collet
796.564.00	Collet chuck 1/4"
796.595.00	Collet chuck 3/8"
796.627.00	Collet chuck 1/2"
797.127.00	Arbor M12x1 - S=1/2" - LB=40

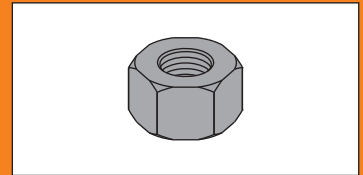
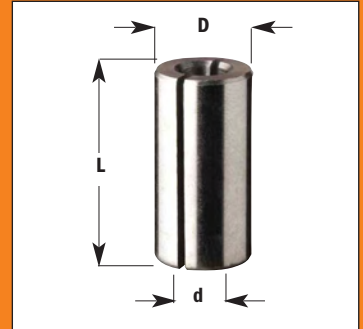
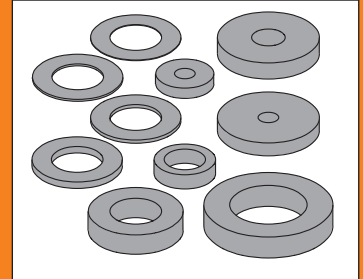

These template systems solve the problems of making arched raised panel doors by eliminating the need for high-cost hold-down jigs. Each of our five 20-piece template packages (#TMP-001 through TMP-005) includes ten sizes for the panels and the ten corresponding templates for the matching arched rails. Each set has templates for doors from 9-1/2" to 22" wide, and each template is stamped with the door width. All templates are made of rugged HDPE plastic.

TMP

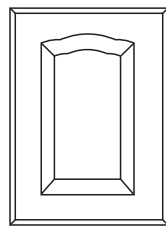

American

Order No.	Description	
TMP-001	French Provincial	Black/White
TMP-002	Classic Country	Black
TMP-003	Cathedral	Blue
TMP-004	Roman	White
TMP-005	American	Yellow
TMP-006	American junior	

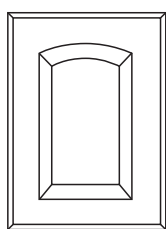

Roman

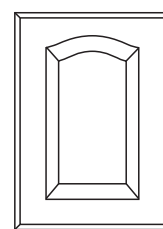

Cathedral

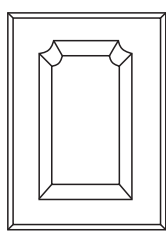

Classic Country

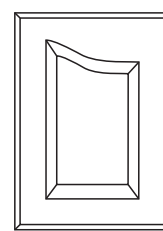
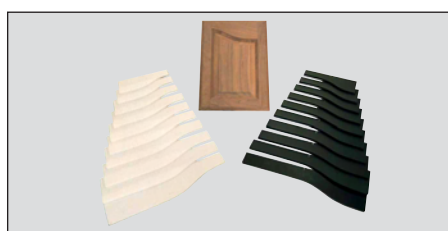

French Provincial

Panalign Strips

Beautiful panel doors can be ruined by a poorly-aligned panel. Next time, slip Panalign Strips into the stiles and rails to keep panels perfectly centered while allowing for expansion.

Unlike carpet foam, which eventually loses elasticity and ceases to work, the rubber in Panalign Strips is specially designed to spring back indefinitely.

The rectangular shape makes the strips easy to handle. Typical doors require 4 to 8 strips each.

PNL

Order No.	Description	
PNL-001	Panalign strips	Qty. 200
PNL-002	Panalign strips	Qty. 500
PNL-003	Panalign strips	Qty. 1.000

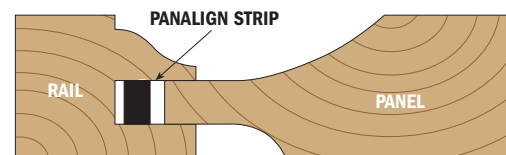

Bit Organizers

Hold up to 100 bits!

When you're working on a project you need your tools organized and close at hand. CMT's Bit Organizer is the perfect solution. This handy molded tray conveniently holds up to 100 router, drill or boring bits. By using our interchangeable bushings, the Organizer will accept any shank diameter. Order bushings from the chart below.

03.51

Order No.	Description
03.51.0106	Bit organizer (without bushings)
03.51.0047A	Interchangeable bushings for 1/4" shanks (20 pieces)
03.51.0057A	Interchangeable bushings for 3/8" shanks (20 pieces)
03.51.0058A	Interchangeable bushings for 10mm shanks (20 pieces)
03.51.0049A	Interchangeable bushings for 1/2" shanks (20 pieces)



cmtusa.com

The ENLOCK system creates fast, simple rock solid joinery for a multitude of woodworking projects. At the heart of the jig, there is a CMT pattern style dovetail bit. The bearing on the dovetail bit rides in and out of the dovetail socket guide on the Enlock table and it cuts perfect dovetail sockets every time. These sockets are ready to receive the dovetail keys.

There are two sizes of dovetail keys (3/8" and 1/2") which require two sizes of CMT dovetail pattern bits. The keys consist of two components. They are the cap that contains wedge like prongs and the base that accepts the cap. When the cap prongs are driven into the base, the base expands and secures and locks inside the dovetail socket.

The material can be accurately positioned in the jig in a variety of ways. It can be centered by utilizing the left and right rulers built into the jig face or the rulers can be used to set the stops. The dimension of the ruler indicates the precise distance to the center of the dovetail socket. There is also a 45° fence and stop system included with the jig for joining mitered materials. The ENLOCK System is ideal for joining T joints, corner joints, miter joints and it is perfect for clamp free edge to edge joinery

CMT-Enlock1

Patent No. AU2005/903586
PCT/AU2006/000957

Width rang
1-3/16"~2-61/64"

Thickness range
3/4"~1-3/8"

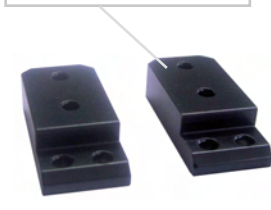

Standard Equipment
Joining system **CMT-Enlock1**
Masterpack (50 keys) **CMT-Enlock10**
Instruction manual (five languages)
Video available on www.cmtutensili.com
Dovetail bit included!



Supplied in a solid plastic box

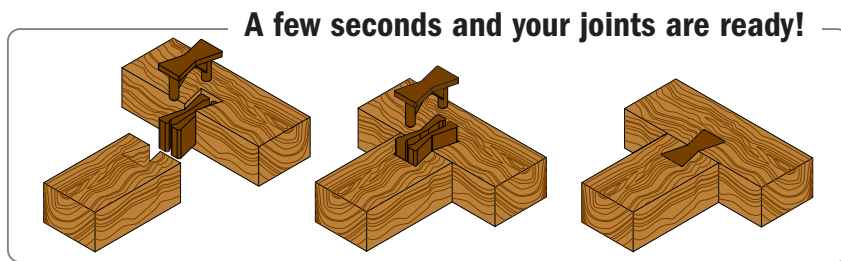

A few seconds and your joints are ready!

Order no.	Description
CMT-Enlock1	Complete joining system
CMT-Enlock10	Masterpack 50 keys Ø3/8"
CMT-Enlock15	Masterpack 50 keys Ø1/2"
818.098.11B	Dovetail bit Ø3/8" (shank 1/4")
818.128.11B	Dovetail bit Ø1/2" (shank 1/4")

Here are a few of the beautiful joints you can produce using the CMT-Enlock Jig



The CMT-Enlock dovetail key expands when the cap is forced in.
This widens the dovetail producing a strong clamping force across the joint.
No other dovetail system on the market produces this clamping force.

Patented system

MADE IN ITALY

CMT333-03

The innovative CMT333 Universal Hinge Boring System employs three spindles which allow you to bore the holes for all of the major hinge brands. The universal modular base supports the installation of five different boring heads and the system can be utilized using drill presses or hand held power tools. The CMT333 is ideal for custom cabinet makers and it is a perfect compliment to boring machines that are dedicated to a specific brand.

The complete system CMT333-03 contains the modular base support and the boring head for Blum, Salice, Häfele and the 35mm hinge. (drill bits and boring bits not included).

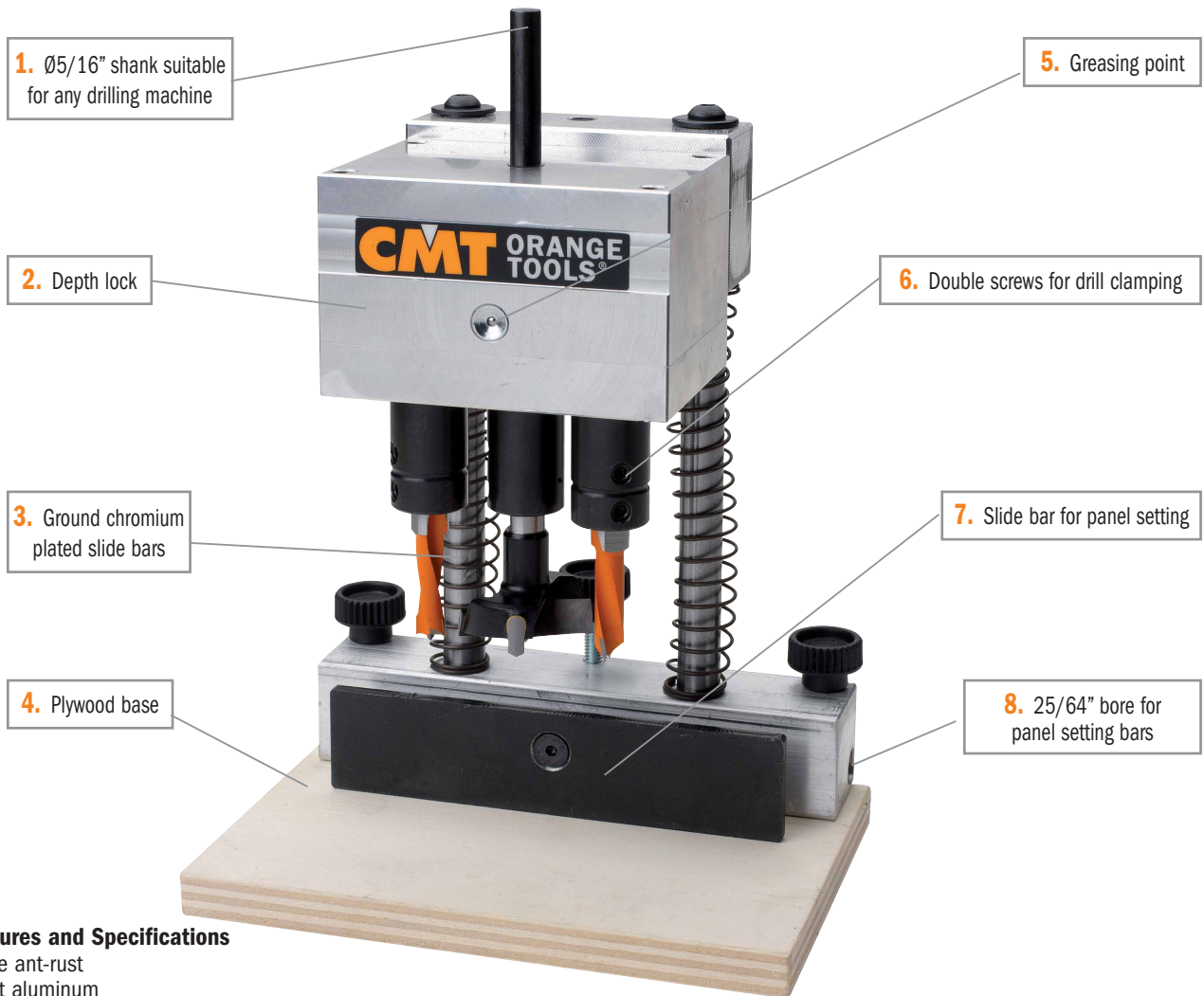

Technical Features and Specifications

- Metal parts are ant-rust
- Ground aircraft aluminum
- Max 5000 RPM
- Six radial anti-friction bearings

Safety Tips: for lubrication use oil Mobil SHC100



For use on drill presses



For use with portable drills



For use on CMT Industrio™ router table

Create your custom made universal boring system buying the components separately:

- universal modular base (CMT333);
- boring heads for different hinge brands (Grass, Blum, Salice, Häfele, Mepla, Hettich and Würth);
- boring head for system 32 (CMT333-325);
- drill bits and boring bits.

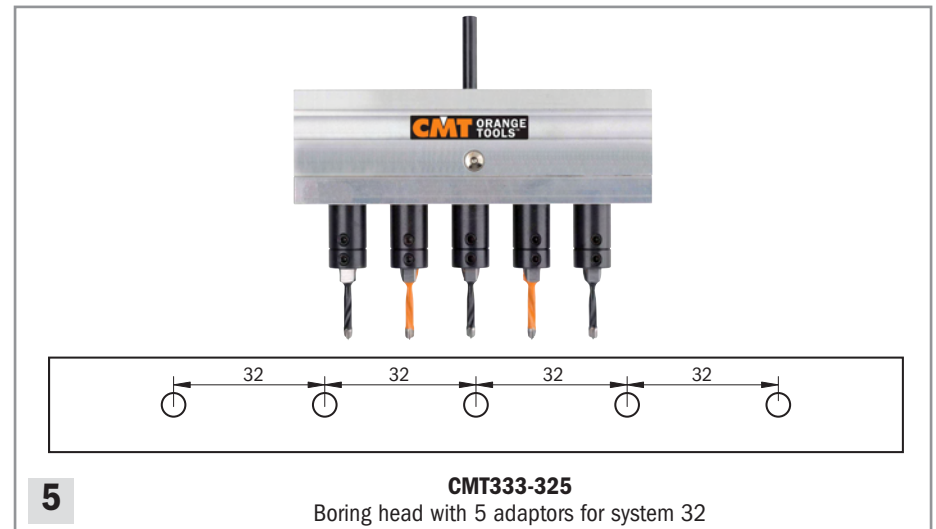
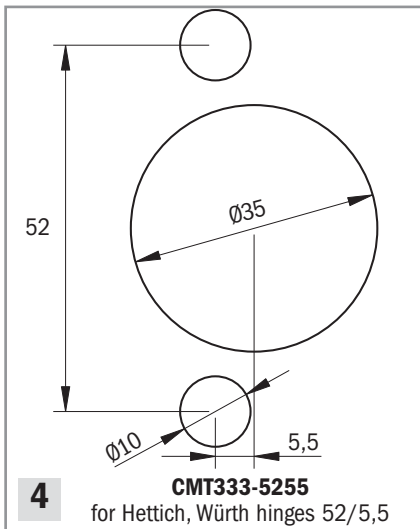
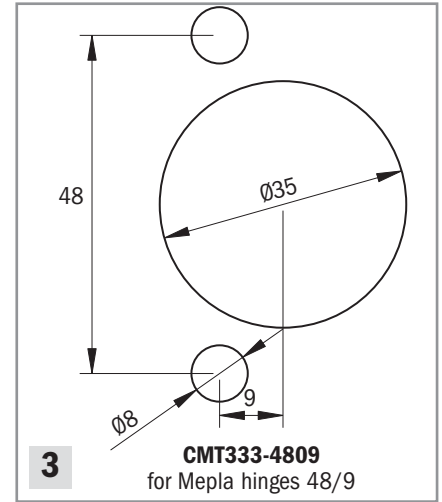
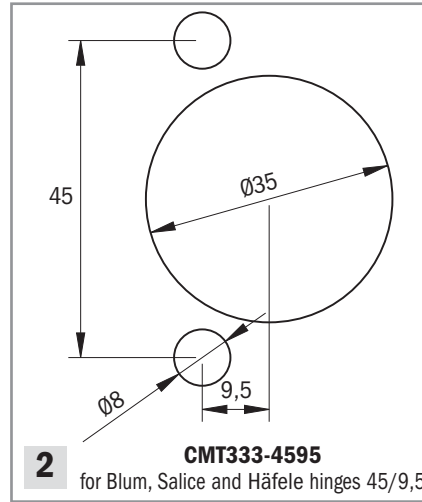
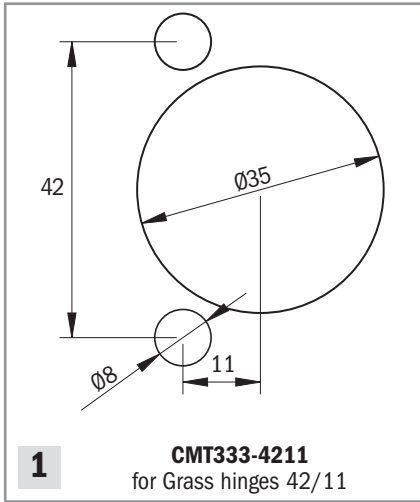

MAXIMUM VERSATILITY FOR ANY BRAND

Make your set

Choose your hinge

1	Grass	42/11
2	Blum	45/9,5
3	Mepla	48/9
4	Hettich, Würth	52/5,5
5	System 32	

Support modular base	Boring heads	Drill bits	Boring bit
ORDER NO.	ORDER NO.	ORDER NO.	ORDER NO.
CMT333	CMT333-4211 Grass	310.080.12 (2 pcs.)	317.350.11
CMT333	CMT333-4595 Blum	310.080.12 (2 pcs.)	317.350.11
CMT333	CMT333-4809 Mepla	310.080.12 (2 pcs.)	317.350.11
CMT333	CMT333-5255 Hettich	310.100.12 (2 pcs.)	317.350.11
CMT333	CMT333-325 System 32	310.050.11/12 (5 pcs.)	

CMT300

Max Length 12"
Joint Thickness 7/16"~1"

Dovetail joints give a lasting symbol of craftsmanship to your work, but many woodworkers avoid the joint due to its apparent complexity. CMT's new 12" Dovetail Jig is the fast, easy solution. With precise templates, permanent stops and easy adjustments, we've taken the "tinkering" out of dovetail joinery. You simply clamp your workpieces in with the edges against the factory-set stops, set your bit depth, and you're ready to rout. We haven't cut any corners on quality either. This jig features steel construction throughout - body, templates, stops and clamping bars - so it will still produce perfect joints long after jigs with lightweight plastic parts have gone to the scrap heap. The jig accepts stock from 7/16" to 1" thick, and is capable of producing a variety of joints with the available templates. The standard jig includes a template for 1/2" half blind joints, a template guide (some routers require adapter, see below) and complete instructions. Optional templates are also available for through-dovetail and box joints.

For set up instructions go to woodshopdemos.com



Standard equipment

- Standard blind template Ø1/2" silver color **CMT300-T128**
- Template guide Ø5/8"x5/32"

899.005.00

IMPORTANT TIP

HW DOVETAIL BITS (not included):

- 818.128.11** D=1/2" A=14° Shank=1/4"
- 818.628.11** D=1/2" A=14° Shank=1/2"



Will the template guide fit my router?
The guides attach using two screws spaced 2" on center. Many routers accept this design. If your router does not, order the Universal Base listed below.

Order No.	Description
CMT300-SB2	Universal router base - Shank Ø1/4" and Ø1/2"

Order No.	Description
CMT300	Dovetail jig

Here's how it works:

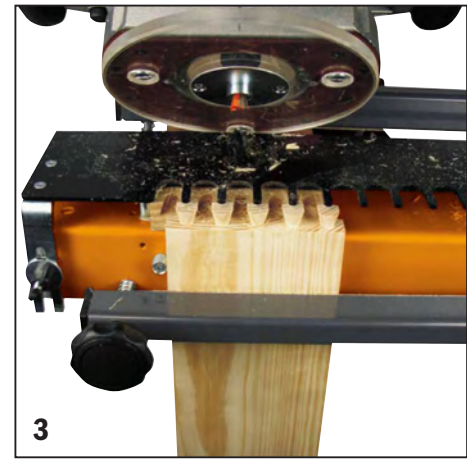
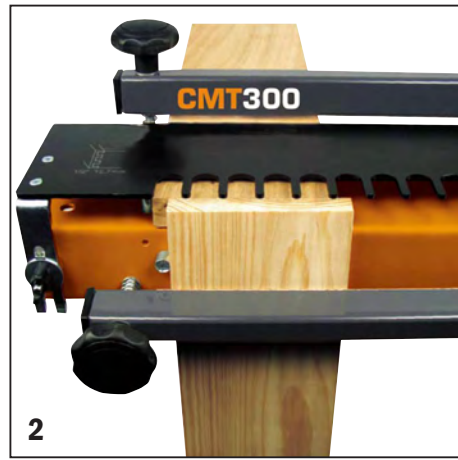

Half blind template

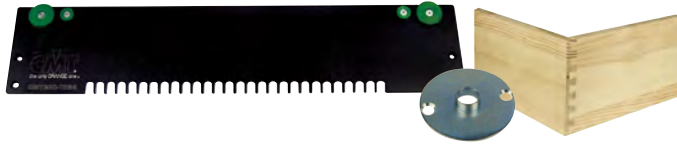

CMT300-T064

Order No.	Template length inches	Dovetail size inches	Thickness inches	Color
CMT300-T064	12	1/4	5/16 ~ 15/32	green

Supplied with precision guide $\varnothing 5/16"$ x $5/32"$ (Order No. 899.003.00)

To be use with CMT Dovetail Router bit:

818.064.11 Dovetail bit $\varnothing 1/4"$ x $5/16"$ (shank $\varnothing 1/4"$)

Through dovetail template



CMT300-T129

Order No.	Template length inches	Dovetail size inches	Thickness inches	Color
CMT300-T129	12	1/2	5/16 ~ 25/32	brown

Supplied with precision guide $\varnothing 7/16"$ x $5/32"$ (Order No. 899.004.00)

To be use with CMT Dovetail Router bits:

811.081.11 Straight bit $\varnothing 5/16"$ x 1" (shank $\varnothing 1/4"$)

818.129.11 Dovetail bit $\varnothing 1/2"$ x $13/16"$ (shank $\varnothing 1/4"$)

Box joint template



CMT300-T080

Order No.	Template length inches	Dovetail size inches	Thickness inches	Color
CMT300-T080	12	5/16	5/16 ~ 25/32	blue

Supplied with precision guide $\varnothing 7/16"$ x $5/32"$ (Order No. 899.004.00)

To be use with CMT Dovetail Router bit:

811.081.11 Straight bit $\varnothing 5/16"$ x 1" (shank $\varnothing 1/4"$)

CMT300-T190

Order No.	Template length inches	Dovetail size inches	Thickness inches	Color
CMT300-T190	12	3/4	19/32 ~ 1	violet

Supplied with precision guide $\varnothing 7/8"$ x $5/32"$ (Order No. 899.006.00)

To be use with CMT Dovetail Router bits:

812.127.11 Straight bit $\varnothing 1/2"$ x 1-1/4" (shank $\varnothing 1/4"$)

811.627.11 Straight bit $\varnothing 1/2"$ x 1" (shank $\varnothing 1/2"$)

818.190.11 Dovetail bit $\varnothing 3/4"$ x $7/8"$ (shank $\varnothing 1/4"$)

818.690.11 Dovetail bit $\varnothing 3/4"$ x $7/8"$ (shank $\varnothing 1/2"$)

CMT300-T127

Order No.	Template length inches	Dovetail size inches	Thickness inches	Color
CMT300-T127	12	1/2	5/16 ~ 25/32	red

Supplied with precision guide $\varnothing 5/8"$ x $5/32"$ (Order No. 899.005.00)

To be use with CMT Dovetail Router bits:

812.127.11 Straight bit $\varnothing 1/2"$ x 1-1/4" (shank $\varnothing 1/4"$)

811.627.11 Straight bit $\varnothing 1/2"$ x 1" (shank $\varnothing 1/2"$)

Precision guide for router:

5/16" x 5/32"	899.003.00
7/16" x 5/32"	899.004.00
5/8" x 5/32"	899.005.00
7/8" x 5/32"	899.006.00

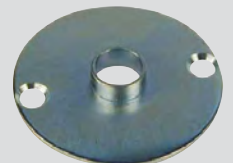

Here are a few of the beautiful dovetail joints you can produce using CMT bits

Half blind (included)

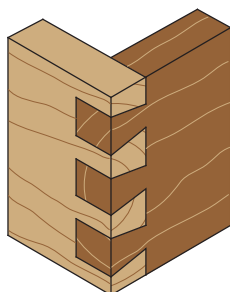

CMT300 - T064
CMT300 - T128

Box Joint

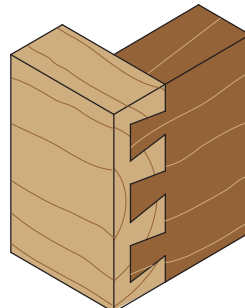

CMT300 - T080
CMT300 - T127

Through dovetail

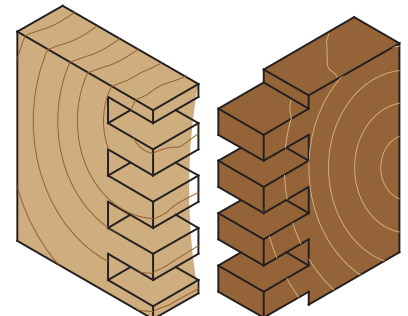

CMT300 - T129
CMT300 - T190

PPJ

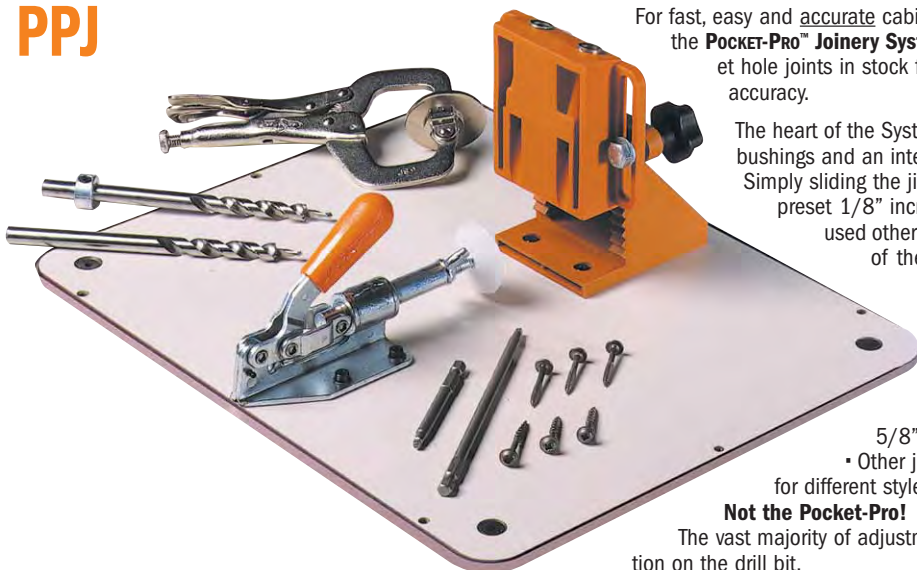

For fast, easy and accurate cabinet & furniture construction, there's never been a tool like the **Pocket-Pro™ Joinery System**. This innovative system lets you make rock-solid pocket hole joints in stock from 1/2" to 1-5/8" thick, with unprecedented speed and accuracy.

The heart of the System is our unique molded jig, which features hardened drill bushings and an interlocking 2-piece design.

Simply sliding the jig up or down allows you to adjust for stock thicknesses in preset 1/8" increments, without test joints or measurements. If you have used other pocket hole jigs you will be familiar with many applications of the joint, **but** you will enjoy some big advantages with the Pocket-Pro:

- Some jigs require that you add or remove portions of the jig to join different stock thicknesses.

Not the Pocket-Pro! You simply adjust the interlocking jig up or down for the full range of joints, from 1/2" to 1-5/8" thick.

- Other jigs require frequent repositioning of the Depth Stop Collar for different styles of joint.

Not the Pocket-Pro!

The vast majority of adjustments allow you to leave the Stop Collar in the same position on the drill bit.

- With the **Pocket-Pro**, you can adjust the location of the pocket in relation to the end of the workpiece to create a stronger joint by using longer screws or to leave more "meat" in the joint.

Check out the Pocket-Pro Joinery System today. Easy enough for the beginner and accurate enough for the pro, the Pocket-Pro is the world's most versatile pocket hole jig.

Order No.	Description
-----------	-------------

PPJ-001	Pocket-Pro deluxe set
----------------	-----------------------

PPJ-002	Pocket-Pro starter set
----------------	------------------------

Enjoy Easy Pocket Hole Joinery!

1. Set jig & bit depth

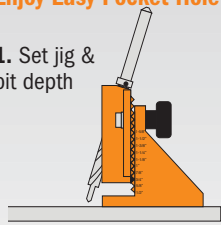

2. Clamp & drill stock

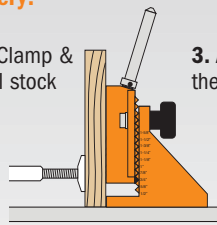

3. Assemble the joint!

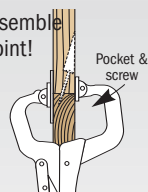

Build almost anything!

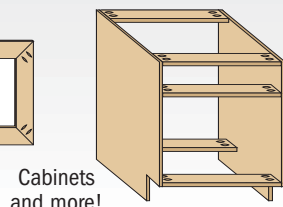
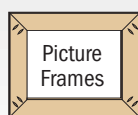
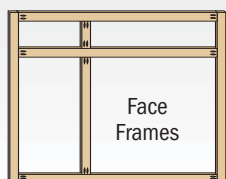

Order No.	Description	Q.ty
-----------	-------------	------

990.101X500	Screws 1-1/4" fine	500
--------------------	--------------------	-----

990.101X500-X11	Screws 1-1/4" fine (11 boxes)	
------------------------	-------------------------------	--

990.102X500	Screws 1-1/4" coarse	500
--------------------	----------------------	-----

990.102X500-X11	Screws 1-1/4" coarse (11 boxes)	
------------------------	---------------------------------	--

990.103X500	Screws 1-1/2" fine	500
--------------------	--------------------	-----

990.103X500-X11	Screws 1-1/2" fine (11 boxes)	
------------------------	-------------------------------	--

990.104X500	Screws 1-1/2" coarse	500
--------------------	----------------------	-----

990.104X500-X11	Screws 1-1/2" coarse (11 boxes)	
------------------------	---------------------------------	--

515.001.51	3/8" step drill bit	
-------------------	---------------------	--

541.095.00	3/8" Stop collar	
-------------------	------------------	--

999.505.04	Phenolic base	
-------------------	---------------	--

999.505.05	Toggle clamp for Pocket-Pro	
-------------------	-----------------------------	--

999.505.06	Face clamp with swivel pad	
-------------------	----------------------------	--

999.505.07	3" square driver bit	
-------------------	----------------------	--

999.505.08	6" square driver bit	
-------------------	----------------------	--

PPJ-002



◆ Pocket-Pro™ Starter Set:

Perfect for anyone who wants an economical introduction to pocket hole joinery, this set is also an ideal choice for woodworkers who want to upgrade from another jig. It includes the two-piece molded jig, toggle clamp, 3/8" step drill bit, stop collar, #2 x 6" driver bit, sample screws & instruction book.

PPJ-001



◆ Pocket-Pro™ Deluxe Set:

Packed in a beautiful molded case, the Deluxe system includes the molded jig, an 11-3/4" x 14-3/4" phenolic base, toggle clamp, face clamp, two step drill bits, stop collar, two drivers, sample screws & our full color instruction book.

All parts fit neatly in molded case

999

Designed by CMT and master cabinetmakers, the Industrio Routing System features:

• Unique Phenolic Top

The top measures 23-1/4" x 31-1/8" with an 11-3/4" x 14-3/4" insert plate, and is milled from 3/4" thick phenolic.

A stable and very durable material, phenolic is much more resistant to warping than the melamine tops found on most router tables.

The new insert plate simplifies router installation, and it includes easy-to-adjust leveling screws. The top also features aluminum scales on both ends to help set the fence quickly and accurately.

• Fast, Easy Bit Changes

There's no need to remove the router or fumble beneath the top to change bits. A clever bent wrench allows you to change bits from above, quickly and easily.

• New Dual-Action Zero-Clearance Fence

Our extruded aluminum fence now can be used as a conventional locked-in-place fence or as a pivoting fence. New, quick-adjusting clamps on both ends of the fence make adjustments a breeze, especially when used in conjunction with the aluminum scales that we've added to the table top.

The fence also includes a subfence of high density white plastic for an ultra smooth feeding surface, with a replaceable center section to create zero-clearance inserts.

• Sturdy Laminated Cabinet

Our sturdy melamine cabinet measures 27" X 20-1/2" X 35-13/16" high. It assembles quickly with posts and cross dowels, and includes a 2-door storage area to keep bits, wrenches and other tools safe and dust-free.

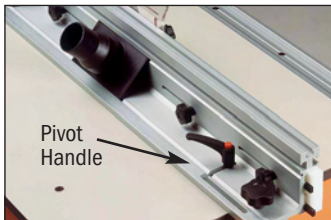

Pivot Handle

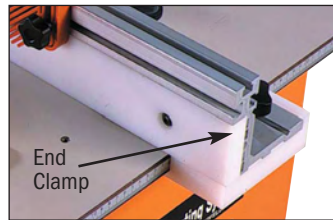

End Clamp

New fence includes pivot pin and quick-adjustment end clamps.



Zero Clearance Inserts for safer, more accurate routing.



Interlocking Insert Rings adapt to suit your bit diameter.

Will my router fit the Industrio Table?

The Industrio System is designed to accept a wide range of popular routers. For most routers, you simply drill holes in the phenolic insert plate to match the threaded holes in the router base. A few routers have holes that are too close together to clear our 4-7/16" diameter aluminum insert rings. In these cases you will need to purchase or fabricate an adapter plate, or in the case of small, lightweight routers you may be able to drill and countersink one or more installation holes in the ledge supporting the insert rings. Before buying the table check the illustration below to see if your mounting holes will be outside the aluminum rings.

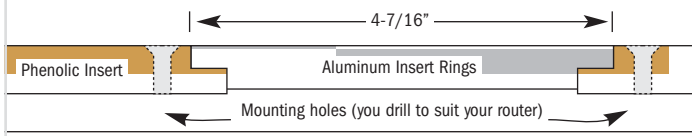

Order No.	Description
999.501.07	Featherboard
991.001.00	Bent Wrench for Porter Cable
991.002.00	Bent Wrench for Hitachi
991.003.00	Bent Wrench for Bosch & Makita
991.004.00	Bent Wrench for DeWalt & Fein
999.501.06	Dual Post and Guard
999.501.08	Miter Gauge (not shown)

Order No.	Description
999.500.02	Industrio™ Routing System
Individual router table parts:	
999.501.10	CMT Industrio™ Precision Fence
999.501.09	CMT Phenolic Routertop w/insert
999.501.03	CMT Industrio™ Router Cabinet
999.501.04	Zero Clearance inserts (3 pcs.)
999.502.33	Centering Tool
999.501.11	Insert plate with aluminium rings

For set up instructions go to woodshopdemos.com



Optional Featherboards

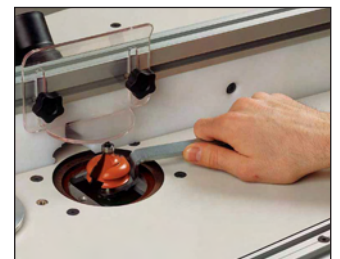

Optional Bent Wrench

899

Beautiful, professional-quality inlays aren't as difficult as they seem. In fact, they're easy with a CMT Inlay Kit. Solid brass components come with either a solid carbide spiral bit or straight bit with 1/8" cutting diameter and 1/4" shank. Just remove and reassemble the small bushing to make the recess in the workpiece and cut out the inlay. Perfect for toymaking, puzzle making, lettering and lots of other decorative projects. Use the spiral bit for routing MDF, or the straight bit for natural wood.



Order No.	Description
899.051.00	Complete Inlay kit (with 192.001.11)
899.052.00	Complete Inlay kit (with 812.032.11)
set contains:	
899.001.00	Solid brass template guide
192.001.11	Solid carbide spiral bit
812.032.11	Solid carbide straight bit

The CMT Inlay Kit consists of 1 template guide, 1 bushing and 1 locking ring. For best results, use either a 1/8" CMT straight bit item #812.032.11 or CMT spiral router bit item #192.001.11. The Inlay Kit is designed for internal or external pattern routing and requires the operator to make and/or follow a pattern for a perfect match.

MAKE A PATTERN

Make a pattern of the desired shape out of 1/4" thick material. **See diagram 1** Masonite or similar material is recommended to provide a smooth surface for the template to run against during the cutting operation. Make the pattern with 3" - 5" of excess material around the perimeter to allow for clamping and to support the router base when designing the pattern. Remember to make the opening large enough to accommodate the 9/16" bushing. Also remember that patterns with a square corner or tight radius will require slight modification of the piece to be inlaid. Instructions for using the internal pattern style are given below. If you choose the external pattern, reverse the procedure for installing and removing the bushing. Cut the external pattern so you preserve the image or design as shown in diagram 2.

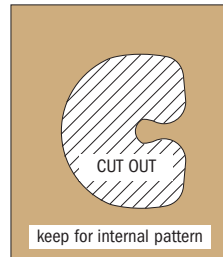

DIAGRAM 1

For internal patterns, cut with a scroll saw. You should end up with a one piece pattern as shown in diagram 1. Preserve the exterior part.

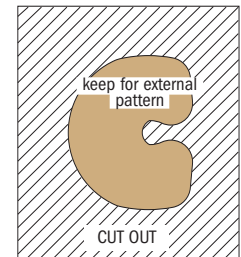

DIAGRAM 2

For external patterns

INSTALLATION

Attach the two-piece brass inlay guide to your base plate with the locking ring. Ensure that the guide lip extends below the router base, and tighten the locking ring until snug. Set the cutting depth of the router to the equivalent thickness of the inlay material (not to exceed 1/8").

See diagram 3

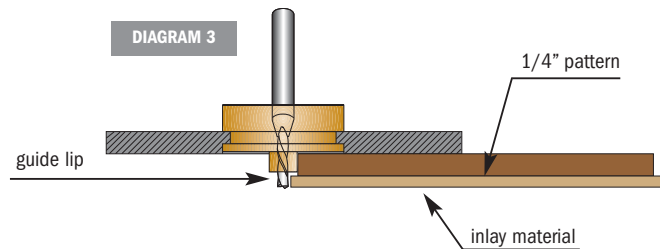
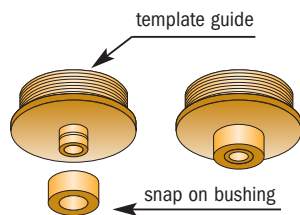

NOTE: This inlay template is designed to fit Porter-Cable style base holes and your router may require an additional adapter available from the manufacturer.

ROUTING THE WORK

Clamp the internal pattern to the workpiece and ensure neither will slip. **See diagram 4** Place the bushing onto the template guide, previously installed on the router. Carefully lower or plunge the cutter into the workpiece, with the bushing rubbing against the edge of the pattern. Run the router clockwise around the inside of the pattern. This will produce an outline of your pattern and the start of the recess to receive the inlay. See diagram 5 The remaining material must be routed out by moving the router back and forth. Some slight clean-up of any high spots may be done with a chisel.

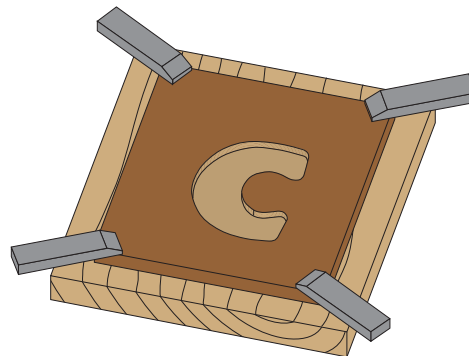

DIAGRAM 4

internal pattern clamped to workpiece

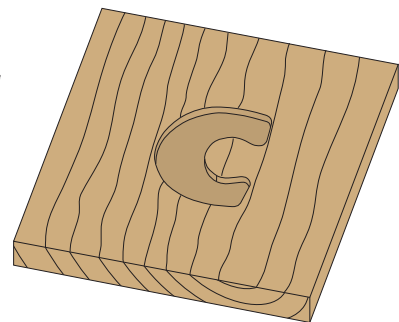

DIAGRAM 5

Routed workpiece: the workpiece has the area routed out 1/8" deep or less and is ready to receive the inlay.

Note: An external pattern is much more difficult to clamp. Double-sided tape may also be used to secure the patterns to the workpiece.

ROUTING THE INLAY

The area from which the inlay will be cut should be secured to a piece of scrap wood using two-sided adhesive tape. This will prevent the inlay from chipping or flying out when the cut is completed.

Place the same pattern over the material from which the inlay will be cut and clamp securely. See diagram 6. Remove the small bushing and carefully route clockwise around the pattern. Ensure that you stay tight to the perimeter of the pattern, as any deviation will show up in the finished work.

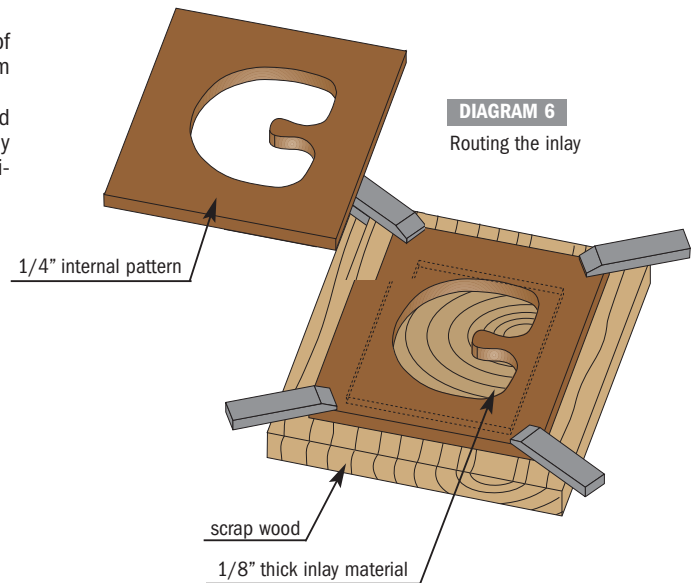
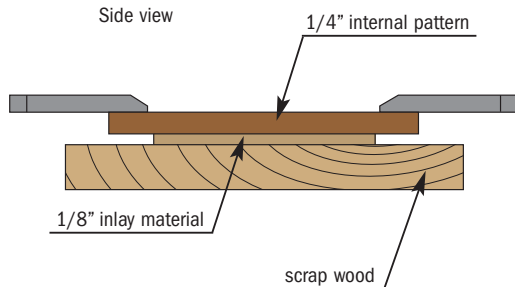

DIAGRAM 6
Routing the inlay

INSERTING THE INLAY

Check the fit by partially inserting the inlay stock into the workpiece recess. It will likely be necessary to sand the edges and corners of the inlay to provide an exact fit into the recess. You will have a tight fit and care must be taken not to over-sand, which would result in a poor fit. Difficulty in insertion will likely be in a corner or small radius so trim there first. Do not press the inlay completely into position unless you intend for it to stay. One inserted it is very difficult to get out, even without glue.

When ready for final assembly, apply a small amount of the appropriate adhesive to both mates. Take a small scrap of wood and, with a hammer or your hand, gently tap the scrap to drive the inlay into position. See diagram 7. Your desired effect will be evident and if the recess is cut to a depth equal to the thickness of the inlay it will be flush with the surface. Of course, you may sand either the workpiece or the inlay to achieve that effect. This is also designed to permit the inlay to stand proud of the surface or be slightly recessed.

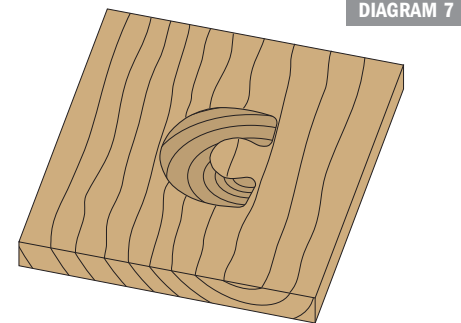

DIAGRAM 7

Blade & Bit Cleaner

Formula 2050



Safe, effective and environmentally friendly

Professional saw shops know that clean cutting edges run cooler, cut better and last longer. That's why we had several quality blade sharpening services test our Formula 2050. The results? In a word, "Phenomenal!"

Most blade and bit cleaning products work with a dissolving action, using some powerful and nasty chemicals to dissolve wood residues and adhesives.

Our safe and non-toxic Formula 2050 penetrates the microscopic cracks in the resin and attacks the bond between it and the carbide or steel surfaces. The resin releases its grip and you simply wipe it off.

Formula 2050 keeps your tooling clean and helps you increase the time between sharpenings and replacement, and your satisfaction is guaranteed!

★★★★★ **This product received a five-star performance rating from "Wood Magazine"**

- Removes pitch, resin and adhesive residue from all woodworking cutting tools (saw blades, router bits, drill bits, shaper cutters, planer blades, etc.).
- Completely non-toxic, non-flammable and certified biodegradable. Formula 2050 is a safe, earth-friendly product.
- Do not rinse after cleaning. Formula 2050 provides protection from rust and corrosion. Keeps your table saw top rust free too!
- Can be applied by spray bottle or used in ultrasonic cleaners and dip tanks.

Order No.	Description
998.001.01	18 oz. (532 ml.) spray bottle
998.001.01-X12	12-pcs. Formula 2050 cleaner 18 oz. (532 ml.)
998.001.03	1 gal. (3.78 l) plastic jug
998.001.03-X4	4-pcs. Formula 2050 cleaner 1 gal.
998.001.04	5 gal. (18.9 l) plastic bucket
998.001.05	55 gal. (207.9 l) plastic barrel

RCS

Exclusively from your CMT distributor

Turn your router into a remarkable carving tool. It's fast, easy, and a whole lot of fun!

Who says that intricate woodcarving requires an artist's touch? Thanks to the patented 3D Router Carver System, anyone with a 1/2" collet plunge router can create any of the beautiful designs shown on these pages in just minutes. Decorate doors, drawers, cabinets, furniture or just about any flat wooden surface with one or more of these designs.

How does it work? The secret is in the 3D Router Carver Bit and the way that bit interacts with the carving templates. The V-Groove router bit is enclosed in a 45° cone-shaped guide. You rout with the plunge mechanism of your router unlocked, allowing the bit to move up or down as the router moves forward. As the slot in the template gets wider, the bit moves down, producing a wider, deeper V-groove. As the slot gets narrower, the bit moves up, and the groove gets narrower and shallower. It sounds simple, and it is! (that's why the system is patented in the USA and around the world).

Please see the illustrations below for more details on the carving technique. You'll receive complete instructions with your 3D Carver templates. For an informative visual demonstration, check out the 3D Router Carver video.

What do you need to get started?

- The 3D Router Carver Bit
- The Carver Template of your choice
- The Holding Frame to match your template (these are listed in the charts with the templates)
- Your 1/2" collet plunge router

(Note: Be sure the opening in the base of your router is at least 1-7/8" in diameter. If it isn't, you'll need to make a sub-base to accept the large diameter of the 3D Carver bit.)

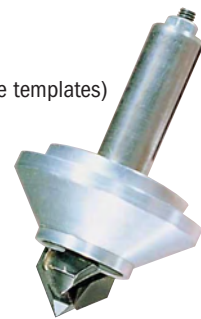

The 3D Router Carver System is protected by U.S. Patent No. 5,146,965

Complete Classical Starter Set

The ideal introduction to the world of router carving. You'll get everything you need to make two of the most popular designs: the Classical Cabinet Door and Classical Drawer, plus two Holding Frames, a 3D Carver Router Bit and a Video, all at a special price! Best of all, the Holding Frames will work with any of our Cabinet Door or Drawer Templates, so you'll be able to add new designs at a minimal cost!

Order No.	Description
RCS-BIT	3D router carver bit
RCS-CUT	3D router spare bit
RCS-DVD	3D router carver DVD
RCS-ST	3D router carver starter set
RCS-VID	3D router carver video



Classical Cabinet Door, #RCS-302



Classical Drawer, #RCS-502

Here's how it works:

1. Clamp or tack the holding frame to your workpiece

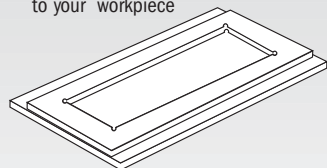

2. Drop the template into the holding frame

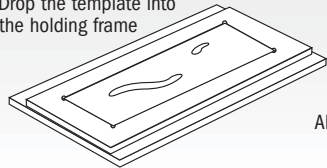

3. Plunge the bit into a wide part of the slot and rout with the router's plunge mechanism unlocked.

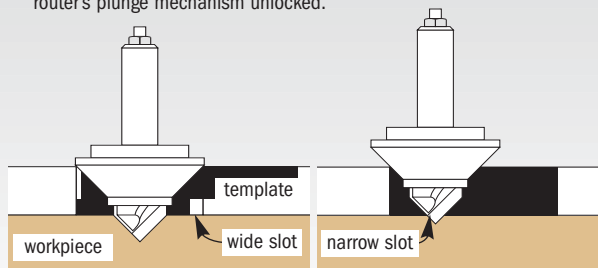

Allow the plunge mechanism to move up and down as you advance. Wider template slots allow wider, deeper grooves. Narrower slots produce shallower grooves.

4. With the frame still in place, flip the template & rout again. Some templates will be routed 2 to 4 times, depending on the complexity of the design.

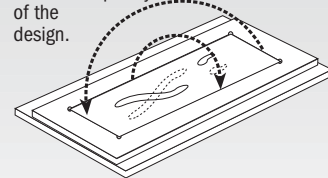

5. Remove the frame and you're finished!

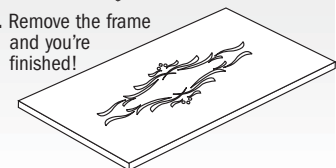

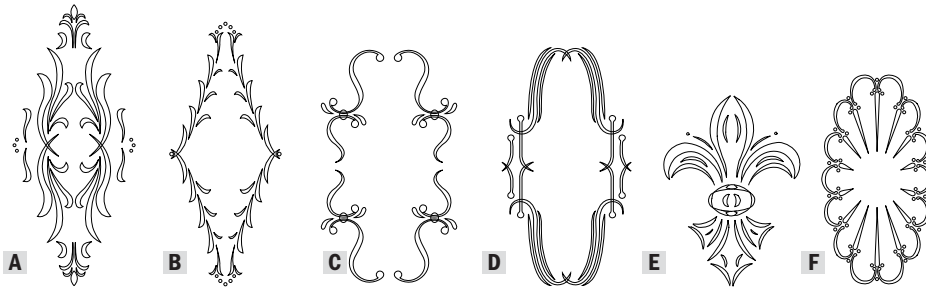

Cabinet Door & Panel Carvings



These designs are ideal for the doors or panels of cabinets, entertainment centers, fireplace surrounds or almost any flat surface. See the designs below for complementary patterns for drawers, rails and corners. Approximate carving time 5 minutes.

Order No.	Description	Carving dimensions inches	No. of templates
RCS-302	Classical cabinet door - A	17-1/4 x 7-1/4	2
RCS-304	Florentine cabinet door - B	16-1/4 x 6-5/8	2
RCS-305	Cascade cabinet door - C	14-3/8 x 8-1/4	1
RCS-306	Roma cabinet door - D	14-3/4 x 7-7/8	1
RCS-805	Fleur-de Lys door - E	9-7/8 x 7	4
RCS-806	Spanish fan template - F	15 x 7-7/8	2
RCS-003	Cabinet door holding frame		

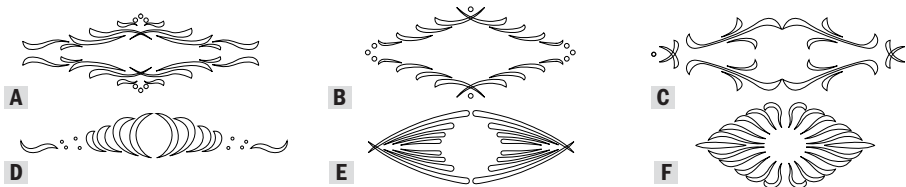

Drawer and Furniture Carvings



Originally intended for drawer fronts, these designs are great for lots of other projects: small doors, side panels of cabinets, furniture and more. For door and drawer combinations, match the style of the door designs above. Approx. carving time 4 minutes.

Order No.	Description	Carving dimensions inches	No. of templates
RCS-502	Classical drawer - A	8-1/4 x 2-3/4	2
RCS-504	Florentine drawer - B	7-5/8 x 3-3/8	2
RCS-505	Cascade drawer - C	9-7/8 x 2-1/2	1
RCS-506	Folklore drawer - D	9-7/8 x 1-1/2	2
RCS-507	Roma drawer - E	7-1/2 x 2-1/2	2
RCS-510	Blaze drawer - F	9-7/8 x 4-3/8	2
RCS-005	Drawer holding frame		

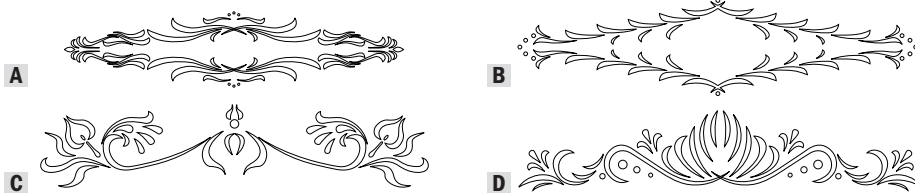

Panel and Rail Carvings



With a long, horizontal shape, these designs are perfect for door rails, headboards, cabinet face frames and valences. Approximate carving time 4 minutes.

Order No.	Description	Carving dimensions inches	No. of templates
RCS-402	Classical rail - A	21-5/8 x 4-3/4	2
RCS-404	Florentine rail - B	21-5/8 x 5	2
RCS-405	Cascade rail - C	20-7/8 x 4-3/8	3
RCS-406	Folklore rail - D	21-5/8 x 4-3/8	3
RCS-004	Rail holding frame		

Tip: Many carvings, like the Florentine Rail, are enhanced with the additional of a Rosette. See page 62 for the Rosette shown in the photo below.



Southwestern Carving Designs

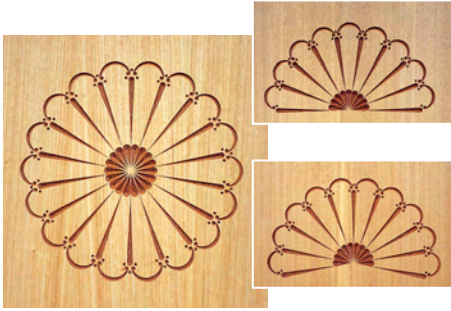

These popular Southwestern designs are actually several shapes in one. Both sizes can be routed as circular carvings, or use only portions of the template to suit your project.

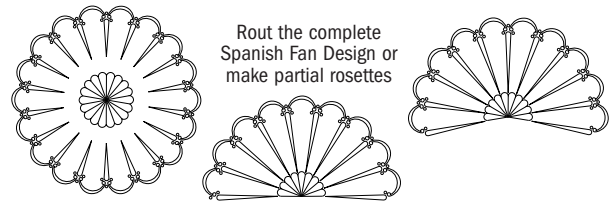

Route the complete Spanish Fan Design or make partial rosettes

Order No.	Description	Carving dimensions inches	No. of templates
RCS-801	Large spanish fan	15-3/4	1
RCS-802	Small spanish fan	7-7/8	1
RCS-007	Rosette holding frame		

Rosette Carvings



You get two templates for the price of one with these designs! Each item includes templates for two sizes of Rosette. Use with the Rosette Frame sold above, or use the large rosettes with the cabinet door frame or small rosettes with rail frame.

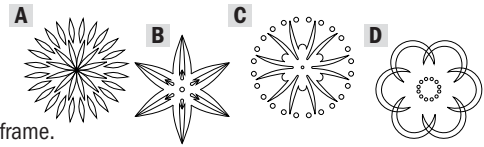

Order No.	Description	Carving dimensions inches	No. of templates
RCS-701	Rosette #1 & #5 - A	3-3/8 & 2-5/8	2 & 2
RCS-702	Rosette #2 & #6 - B	3-1/2 & 2-3/4	1 & 1
RCS-703	Rosette #3 & #7 - C	3-1/4 & 2-1/2	1 & 1
RCS-704	Rosette #4 & #8 - D	3-1/8 & 2-7/16	1 & 1

Just for fun: Designs For every animal lover!

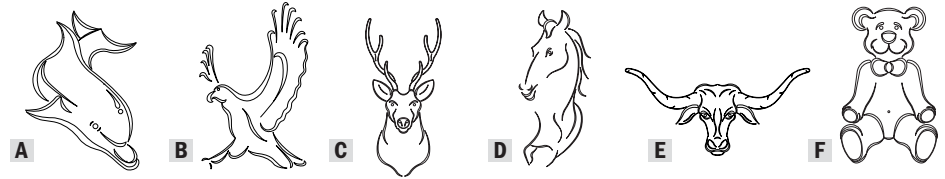

Your imagination will be your guide on these neat designs. Furniture or decorations for the kids, paneling for the den or rec room, a gift for the sportsman - who knows?

Order No.	Description	Carving dimensions inches	No. of templates
RCS-803	Dolphin - A	7-7/8 x 11-7/16	4
RCS-804	Eagle - B	7 x 11-3/4	4
RCS-901	Deer - C	15-1/2 x 7-1/2	4
RCS-902	Horse - D	17-1/2 x 8	3
RCS-904	Longhorn - E	16-1/2 x 7-5/8	4
RCS-906	Teddy bear - F	15-1/2 x 8	3
RCS-003	Cabinet door holding frame		

Corner & Small Decoration Carving Designs



Order No.	Description	Carving dimensions inches	No. of templates
RCS-602	Classical corner - A	6-1/8 x 1-9/16	3
RCS-604	Florentine corner - B	4-3/4 x 1-1/8	3
RCS-605	Cascade corner - C	7-1/2 x 1-9/16	3
RCS-606	Folklore corner - D	6 x 1-3/4	3
RCS-006	Corner holding frame		

Router Bits with Replaceable Knives



Single Flute Straight Bits 100



Straight Bits with Plunging Knives 101



Pattern Bits 102



Double Flute Flush Trim Bits 102



Double Flute Chamfer Bits 103



Double Flute Roundover Bits 103

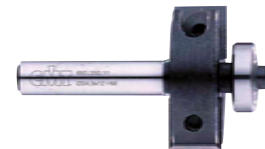

Double Flute Rabbeting Bits 105



Single Flute Straight Bits

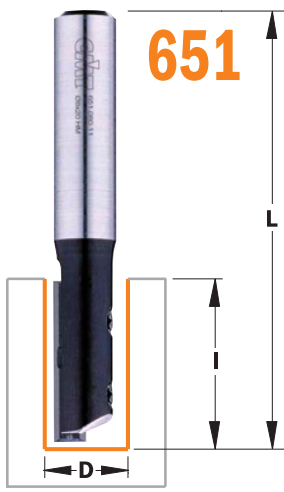

CARBIDE TIPPED **Z1**

Ideal for fast plunge cuts and other grooving applications. Use these single edge bits in CNC or portable routers for work in laminated stock or hard and soft woods.

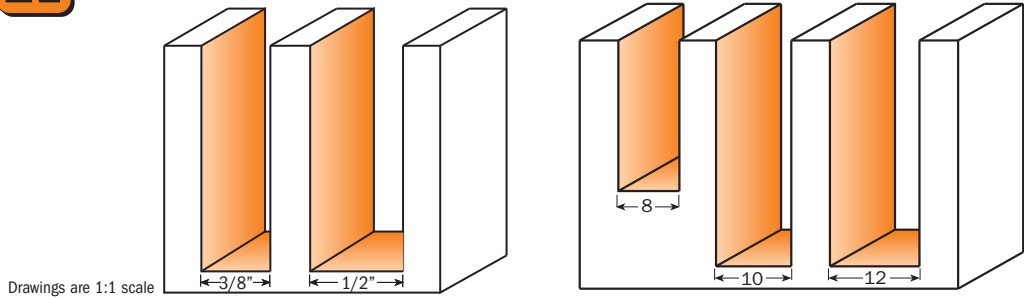

Drawings are 1:1 scale

Order No. 1/4" shank	Order No. 1/2" shank	D_Cutting diameter inches	D_Cutting diameter mm	I_Cutting length mm	Knives mm
651.079.11	651.681.11	5/16	8	20	20 x 4.1 x 1.1
651.095.11	651.695.11	3/8	9.52	30	30 x 5.5 x 1.1
	651.701.11		10	30	30 x 5.5 x 1.1
	651.721.11		12	30	30 x 5.5 x 1.1
651.127.11	651.727.11	1/2	12.7	30	30 x 5.5 x 1.1
spare parts:		790.200.01 Knives 20 x 4.1 x 1.1mm	651.999.02 Wedge for knives 30x5.5x1.1mm	990.071.00 Torx screws M2.5x5mm	
		651.999.01 Wedge for knives 20x4.1x1.1mm	990.071.00 Torx screws M2.5x5mm		
		790.300.01 Knives 30x5.5x1.1mm	991.063.00 Torx key T8		

Long Straight Bits for Laminates

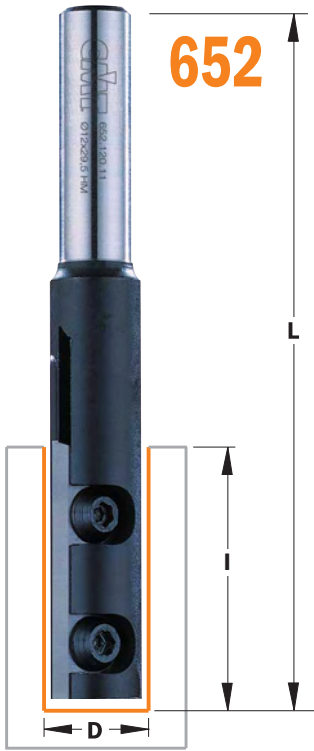

CARBIDE TIPPED **Z1**

Primarily for use in portable routers, these extra-long single-edge bits deliver clean cuts in laminated MDF and other composites, as well as hard or soft wood.

652B

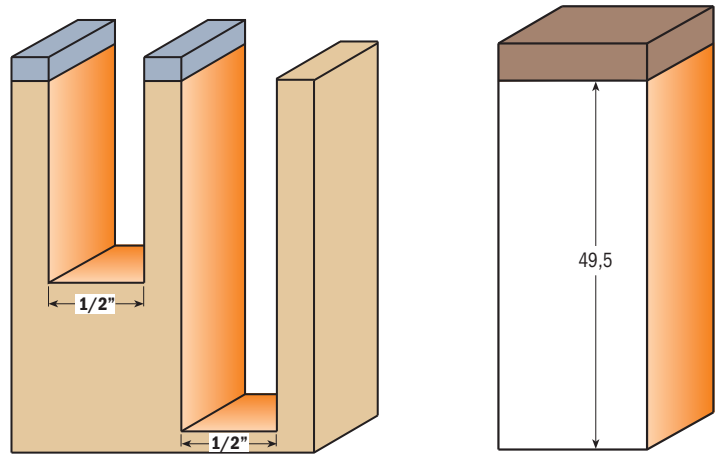
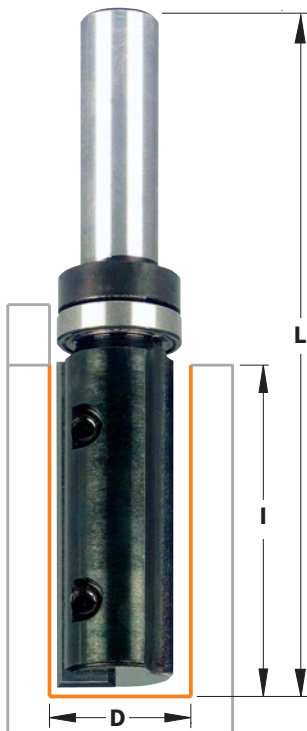

Drawings are 1:1 scale

Order No. 1/2" shank	D_Cutting diameter inches	D_Cutting diameter mm	I_Cutting length mm	Knives mm
652.621.11		12	50	50 x 9 x 1.5
652.627.11	1/2	12.7	29.5	29.5 x 9 x 1.5
652.628.11	1/2	12.7	50	50 x 9 x 1.5
652.691.11B	3/4	19	49.5	49.5 x 12 x 1.5
spare parts:		790.295.09 Knives 29.5 x 9 x 1.5mm	790.495.09 Knives 49.5 x 9 x 1.5mm (old version 2 bores)	
		790.500.09 Knives 50 x 9 x 1.5mm (new version 3 bores)	790.495.12 Knives 49.5 x 12 x 1.5mm	
		990.072.00 Torx screws M3.5x3.5mm	991.061.00 Torx key T15	
		791.011.00 Ø12.7mm bearing	541.002.00 Stop collar for Ø12.7mm shank	
		991.056.00 1.5mm allen key for stop collar		

These tools feature a special plunging knife at the tip, as well as a long single cutting edge. Use with CNC or portable routers in composites or solid hard and soft woods.

CARBIDE TIPPED

Z1+1

653

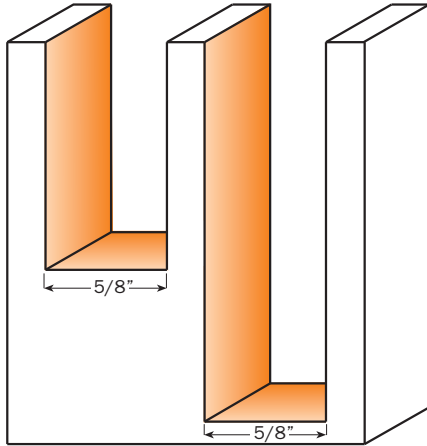

Drawings are 1:1 scale

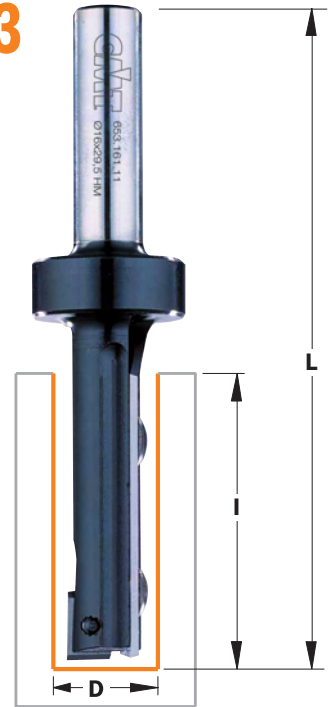

Order No.	D_Cutting diameter		I_Cutting length	Knives
1/2" shank	inches	mm	mm	mm
653.158.11	5/8	15.8	28.3	28.3 x 12 x 1.5
653.159.11	5/8	15.8	48.3	48.3 x 12 x 1.5
spare parts:	790.075.00	Knives 7.5 x 12 x 1.5mm		
	790.283.12	Knives 28.3 x 12 x 1.5mm		
	790.483.12	Knives 48.3 x 12 x 1.5mm		
	990.072.00	Torx screws M3.5x3.5mm		
	990.074.00	Torx screws M4x3.5mm		
	990.075.00	Torx screws M4x6mm		
	991.061.00	Torx key T15		

Double Flute Straight Bits

These double edged bits give extra-clean cuts, and they also feature a special 3° bevel on the top for better plunging action.

CARBIDE TIPPED

Z2

654

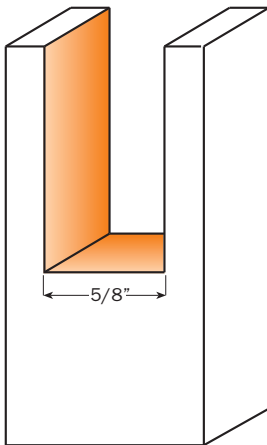

Drawings are 1:1 scale

Order No.	D_Cutting diameter		I_Cutting length	Knives
1/2" shank	inches	mm	mm	mm
654.661.11		16	29.5	29.5 x 12 x 1.5
spare parts:	790.295.12	Knives 29.5 x 12 x 1.5mm		
	990.073.00	Torx screws M3.5x5mm		
	990.075.00	Torx screws M4x6mm		
	991.061.00	Torx key T15		

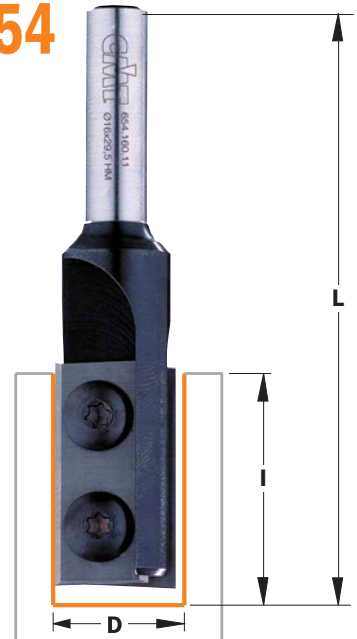

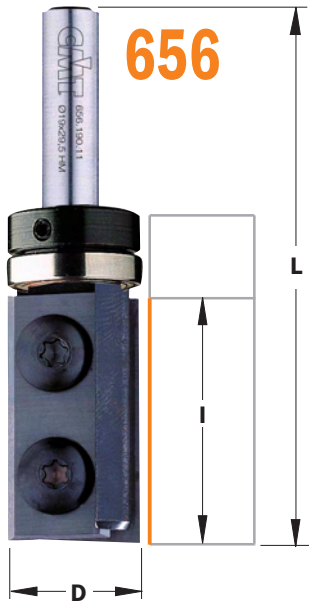

Our pattern bits include a ball bearing guide for all types of template or pattern work. Use with CNC or portable routers in wood or composites. Bit features 2 cutting edges.

Order No. 1/2" shank	D_Cutting diam. inches	I_Cutting length mm	Knives mm
656.691.11	3/4	19	28.3 x 12 x 1.5
656.693.11	3/4	19	48.3 x 12 x 1.5
spare parts:			
790.283.12	Knives 28.3 x 12 x 1.5mm		
790.483.12	Knives 48.3 x 12 x 1.5mm		
990.075.00	Torx screws M4x6mm		
991.061.00	Torx key T15		
791.011.00	Ø12.7-19mm bearing		
541.002.00	Stop collar for Ø12.7mm shank		
991.056.00	1.5mm allen key for stop collar		

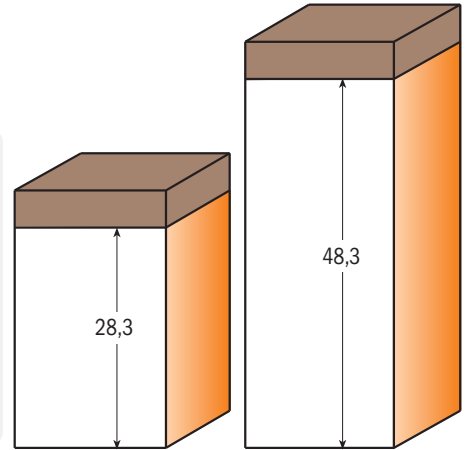

Drawings are 1:1 scale

Double Flute Flush Trim Bits

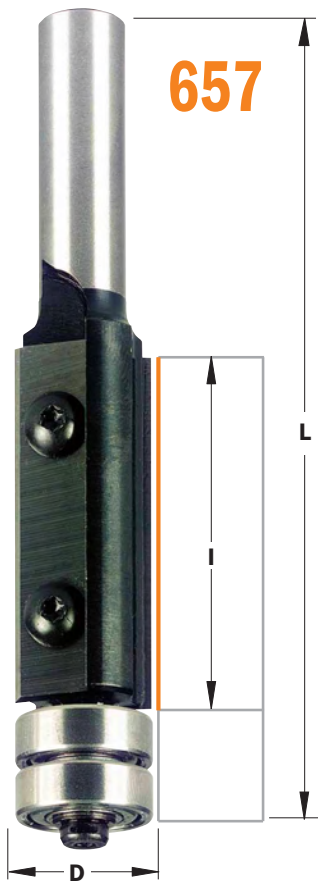

Double edge flush trim bits are great for trimming any laminate. They give lots of extra life too, since the carbide inserts can be ben turned to provide a new, sharp edge.

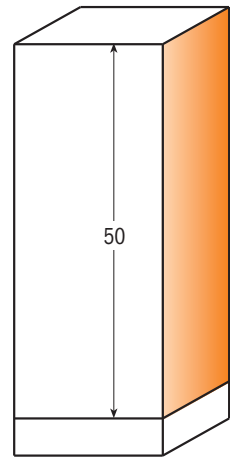
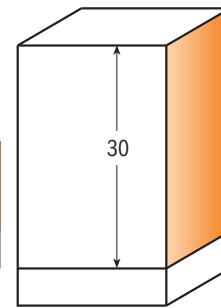
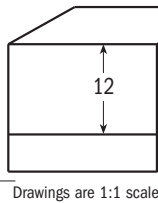
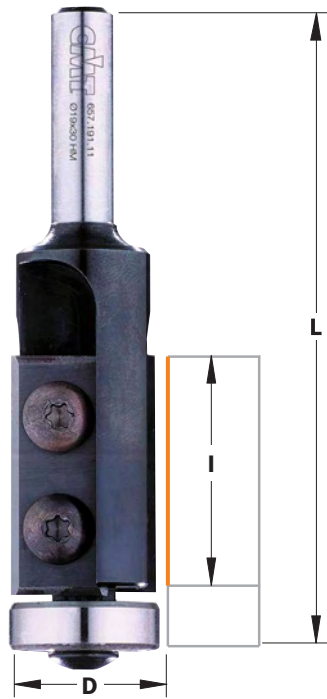

Drawings are 1:1 scale

Order No. 1/4" shank	Order No. 1/2" shank	D_Cutting diameter inches	D_Cutting diameter mm	I_Cutting length mm	Knives mm	Bearing
657.192.11		3/4	19	12	12 x 12 x 1.5	791.007.00
	657.692.11	3/4	19	30	30 x 12 x 1.5	791.007.00
	* 657.992.11	3/4	19	50	50 x 12 x 1.5	791.007.00
spare parts:						
790.120.00	Knives 12 x 12 x 1.5mm			791.007.00	Ø6-19mm bearing	
790.300.00	Knives 30 x 12 x 1.5mm			990.410.00	Washer 4.2/9 for screw M4	
790.500.00	Knives 50 x 12 x 1.5mm			541.514.00	2.2mm shield	
990.075.00	Torx screws M4x6mm			990.052.00	Screw TCEI M4x6mm for bearing	
991.061.00	Torx key T15			991.062.00	2.5mm hex key	

* with double bearing

Use these bits with portable or CNC routers for precise bevels and chamfers in any wood or composite. The inserts are sharpened on 4 sides, so you get 4 sharp edges!

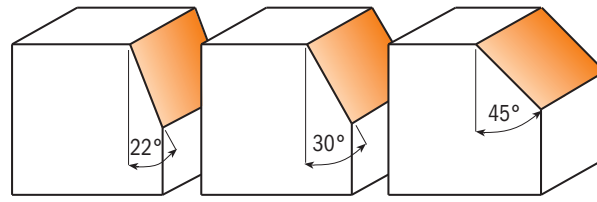

Drawings are 1:1 scale

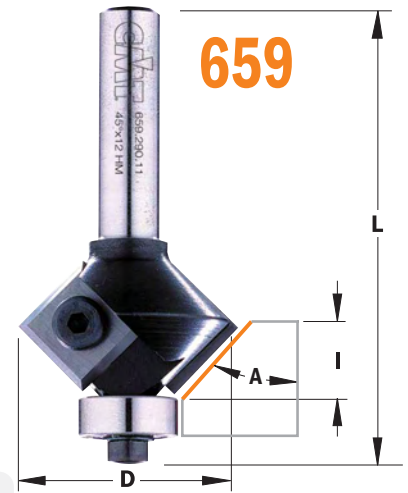

Order No. 1/4" shank	Order No. 1/2" shank	A_Cutting angle	D_Cutting diam. mm	I_Cutting length mm	Knives mm	Bearing
659.023.11		22°	25	12	12 x 12 x 1.5	791.006.00
659.031.11		30°	28	12	12 x 12 x 1.5	791.006.00
659.046.11	659.646.11	45°	29	12	12 x 12 x 1.5	791.022.00
spare parts:		790.120.00 Knives 12 x 12 x 1.5mm	791.006.00	Ø5-16mm bearing		
	990.075.00 Torx screws M4x6mm	990.400.00 Washer 3.2/7 for screw M3				
	991.061.00 Torx key T15	990.051.00 Screw TCEI M3x6mm for bearing				
	791.022.00 Ø5-13mm bearing	991.062.00 2.5mm hex key				

Double Flute Roundover Bits

Best for use with portable routers, our double-edged roundover bits are great for any wood or wood product. Use the 1/16" radius as a durable, efficient laminate trimmer too!

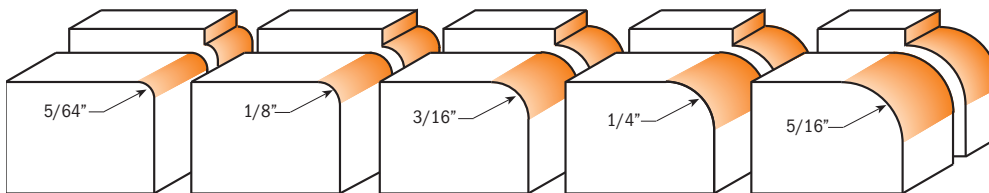

Drawings are 1:1 scale

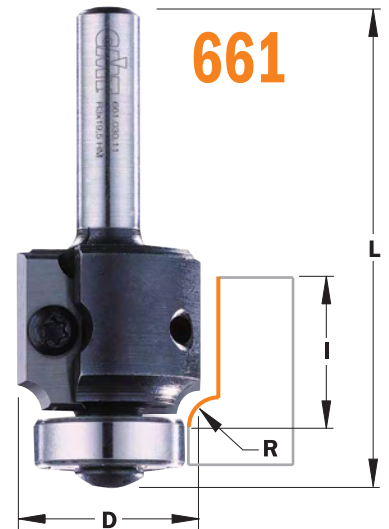

Order No. 1/4" shank	Order No. 1/2" shank	R_Radius inches	D_Cutting diameter mm	I_Cutting length mm	Knives mm	Bearing
661.021.11		5/64	2	22.8	19.5	19.5 x 9 x 1.5 791.007.00
661.031.11		1/8	3	24.6	19.5	19.5 x 9 x 1.5 791.007.00
661.051.11		3/16	5	28.6	19.5	19.5 x 9 x 1.5 791.007.00
661.064.11		1/4	6.35	29	24	24 x 12 x 1.5 791.006.00
	661.581.11	5/16	8	32	24	24 x 12 x 1.5 791.006.00
spare parts:		790.020.00 Knives Radius 5/64"	791.007.00	Ø6-19mm bearing		
	790.030.00 Knives Radius 1/8"	990.410.00 Washer 4.2/9mm for screw M4				
	790.050.00 Knives Radius 3/16"	990.052.00 Screw TCEI M4x6 for bearing				
	790.064.00 Knives Radius 1/4"	791.006.00 Ø5-16mm bearing				
	790.080.00 Knives Radius 5/16"	990.400.00 Washer 3.2/7mm for screw M4				
	990.076.00 Torx screws M4x4mm	990.051.00 Screw TCEI M3x6 for bearing Ø16mm				
	991.061.00 Torx key T15	991.062.00 2.5mm hex key				

Double Flute Rabbeting Bits

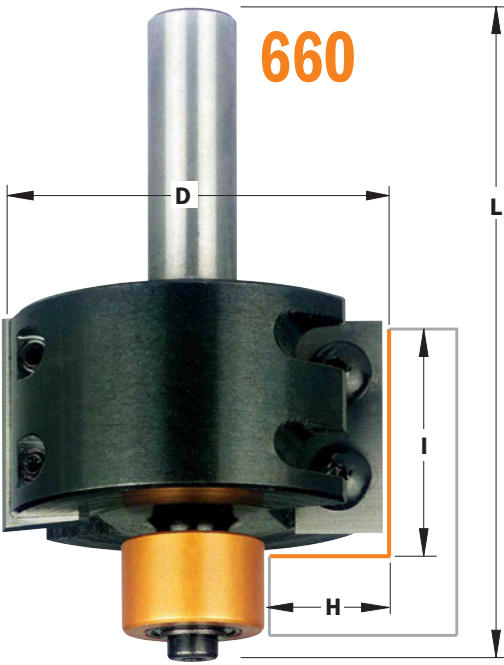

Primarily for use with portable routers, these rabbeting bits can be used with various bearings to produce a wide range of cut depths. Inserts are sharpened on all 4 sides.

Order No. 1/2" shank	H_Cutting depth inches	D_Cutting diam. mm	L_Cutting length mm	Knives mm	Bearing
660.991.11	5/8	15.8	50.8	28.3	28.3 x 12 x 1.5 791.010.00
spare parts:	790.283.12	Knives 28.3 x 12 x 1.5mm			
	990.075.00	Torx screws M4x6mm			
	991.061.00	Torx key T15			
	791.010.00	Ø6.35-12.7mm bearing			
	541.514.00	Shield for screw Ø6.4mm			
	799.503.00	Bushing Ø19.05mm			
	990.410.00	Washer 4.2/9 for screw M4			
	990.052.00	Screw TCEI M4x6mm for bearing			
	991.062.00	2.5mm hex key			
optional:	791.705.00	5 pcs. collar set (1-1/16" - 1/8" - 1/4" - 3/8" - 1/2" rabbets)			
	791.706.00	5 pcs. collar set (3/16" - 5/16" - 7/16" - 9/16" - 11/16" rabbets)			
	791.707.00	5 pcs. collar set (15/64" - 23/64" - 15/32" - 19/32" - 23/32" rabbets)			

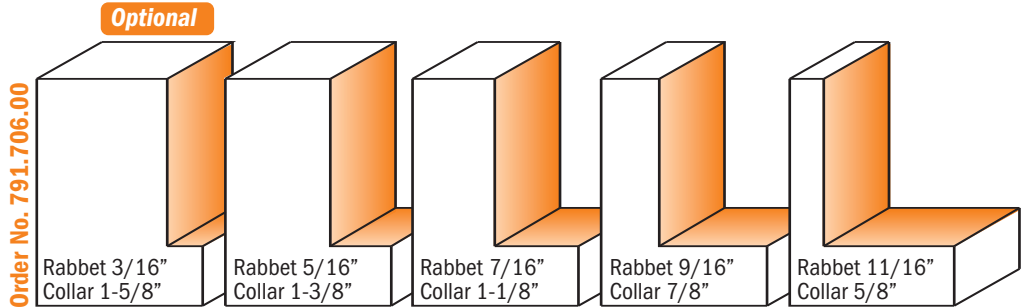
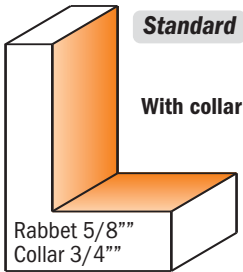
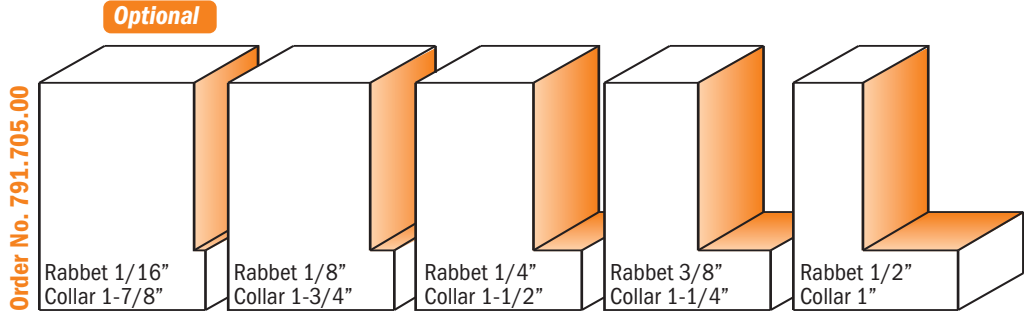
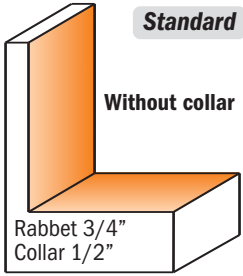
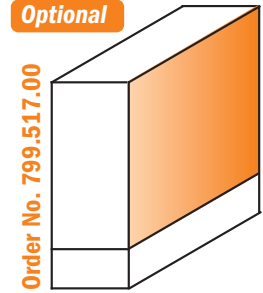

Drawings are 1:1 scale

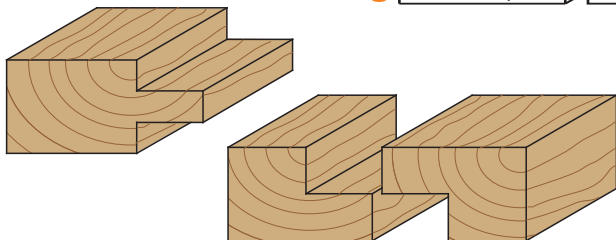
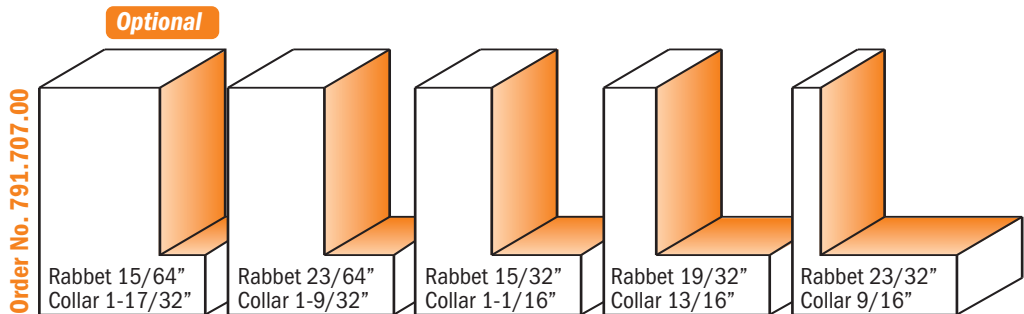

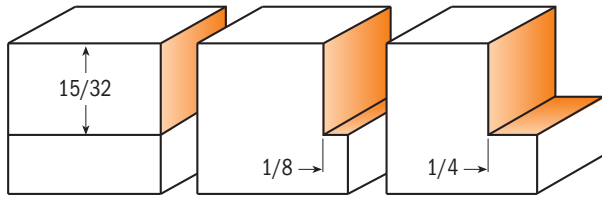

with bearing
791.016.00

with bearing
791.014.00

with bearing
791.017.00

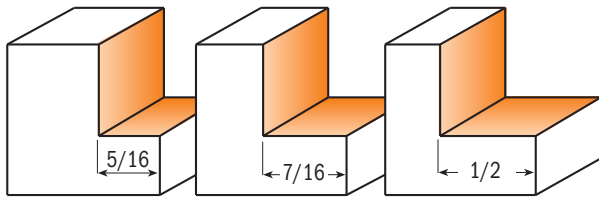

with bearing
791.019.00

with bearing
791.003.00

with bearing
791.002.00

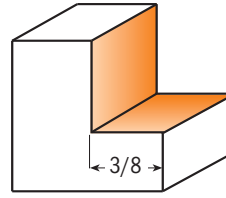

with bearing
791.018.00



Primarily for use with portable routers, these rabbeting bits can be used with various bearings to produce a wide range of cut depths. Inserts are sharpened on all 4 sides.

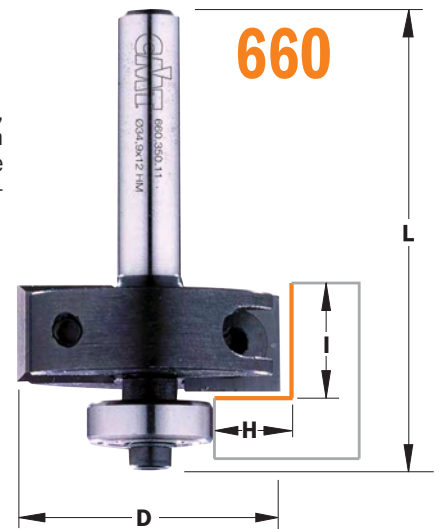

Drawings are 1:1 scale

Order No. 1/4" shank	Order No. 1/2" shank	H_Cutting depth inches	H_Cutting depth mm	D_Cutting diameter inches	I_Cutting length inches	Knives mm	Bearing
660.351.11	660.851.11	3/8	9.5	1-3/8	15/32"	12 x 12 x 1.5	791.018.00
spare parts: 790.120.00 Knives 12 x 12 x 1.5mm				990.051.00 Screw TCEI M3x6mm for bearing (for bearing 791-002-003-018)			
990.075.00 Torx screws M4x6mm				990.053.00 Screw TCEI M3x10mm for bearing (for bearing 791-014-017-019)			
991.061.00 Torx key T15				990.054.00 Screw TCEI M3x16mm for bearing (for bearing 791-016)			
990.400.00 Washer 3.2/7mm for screw M3 (for bearing 791-002-003-018-019)				991.062.00 2.5mm hex key			
541.552.00 Washer 3.25/15.8mm for screw M3 (for bearing 791-016-014-017)							

Spare Parts

791 Bearing

Order No.	D_Cutting diameter inches	D_Cutting diameter mm	d_Small diameter inches	d_Small diameter mm	Thickness mm
791.002.00	3/8	9.5	3/16	4.76	3.2
791.003.00	1/2	12.7	3/16	4.76	5
791.022.00		13		5	4
791.018.00	5/8	15.87	3/16	4.76	5
791.006.00		16		5	5
791.007.00		19		6	6
791.019.00	3/4	19	3/16	4.76	7
791.034.00	3/4	19		8	6
791.011.00	3/4	19	1/2	12.7	4
791.017.00	7/8	22.2	3/16	4.76	7.5
791.014.00	1-1/8	28.5	3/16	4.76	8.4
791.016.00	1-3/8	34.9	3/16	4.76	11.5

990 Torx Screws

Order No.	Description
990.071.00	Torx Screw M2.5x5.5mm
990.072.00	Torx Screw M3.5x3.5mm
990.073.00	Torx Screw M3.5x5mm
990.074.00	Torx Screw M4x3.5mm
990.075.00	Torx Screw M4x6mm
990.076.00	Torx Screw M4x4mm

990 Screws

Order No.	Description
990.051.00	Screw TCEI M3x6mm
990.052.00	Screw TCEI M4x6mm
990.053.00	Screw TCEI M3x10mm
990.054.00	Screw TCEI M3x16mm
990.005.00	Screw STEI M3x3mm

991 Keys for Knives

Order No.	Description
991.063.00	Torx T8 hex key
991.061.00	Torx T15 hex key
991.062.00	2.5mm hex key
991.056.00	1.5mm hex key

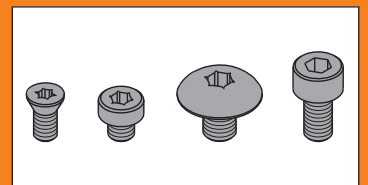

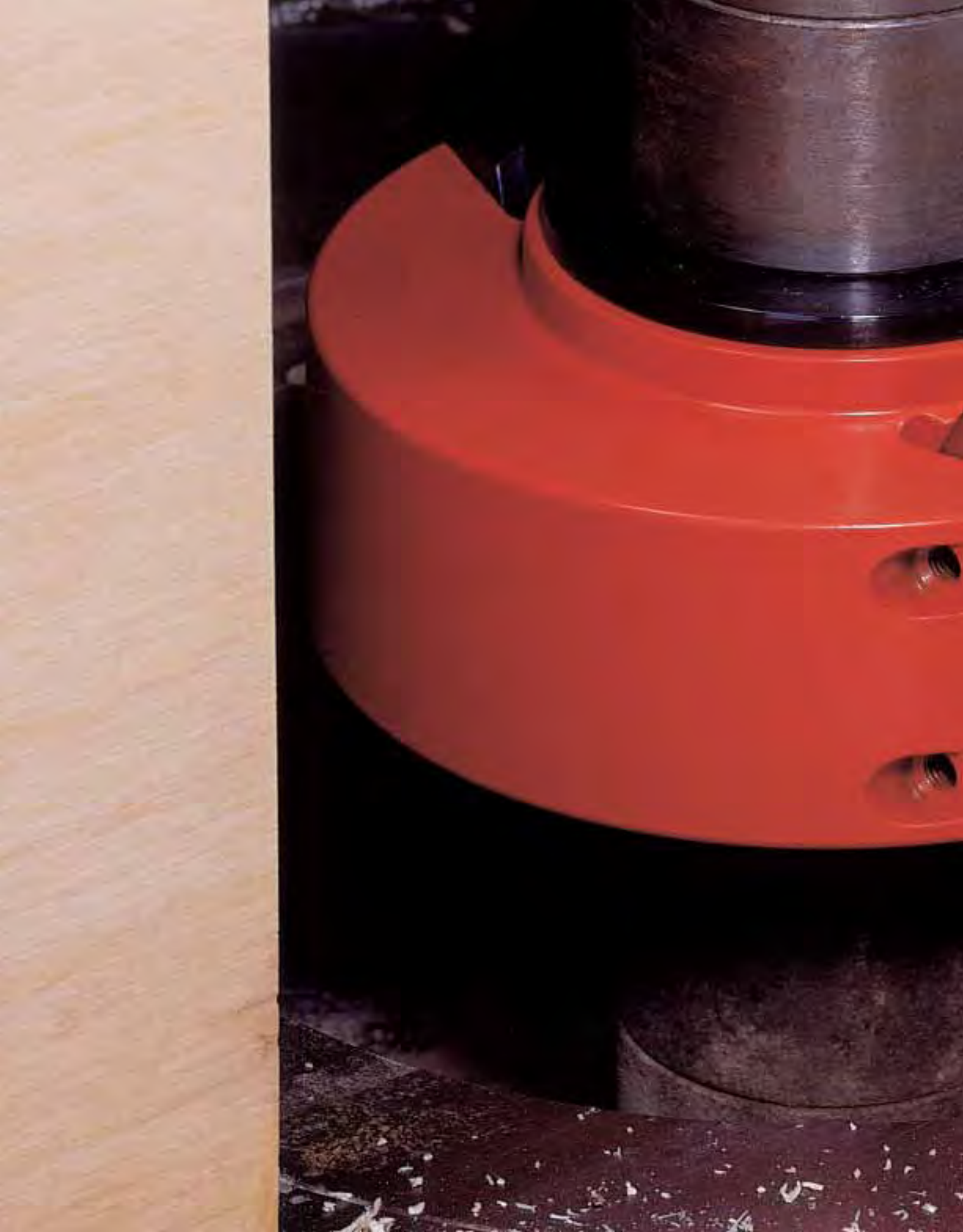



Cutter heads & knives



Rabetting cutter head

108



Multiradius roundover

112



Professional raised panel

118



Rabetting cutter head

123



Multiprofile set with limitors

122



Multiprofile set without limitors

122



Knives and limitors
40-50mm

124~138

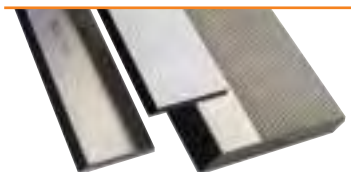

Planer and Jointer knives

138



HWM Reversible knives

140~142

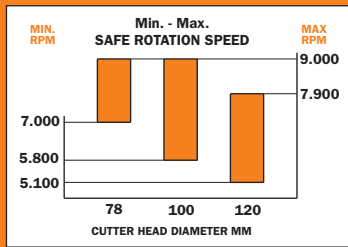

- ALWAYS** thoroughly check all cutters for damage and flaws before using.
- ALWAYS** wear safety glasses and ear protection when using power tools.
- ALWAYS** thoroughly read the owners manual and manufacturer's instructions before working with tools.
- ALWAYS** use guards that were supplied with your shaper.
- ALWAYS** use a fence with your shaper. Do not make freehand cuts.
- ALWAYS** use pusher blocks, especially when working with small or narrow pieces.
- ALWAYS** unplug your shaper before cleaning or adjusting the tool, or before making cutter or knife changes.
- ALWAYS** be sure the spindle nut is tight before plugging in the shaper.
- ALWAYS** check that knives are properly and securely installed in the cutterhead when using interchangeable-knife systems.
- ALWAYS** keep your tools sharpened, clean and stored in a safe place to avoid breakage and accidents and to extend the life of your bits and blades.
- ALWAYS** feed the work against the rotation of the knives.
- ALWAYS** be sure your workpiece is completely supported, before and after the cut.
- NEVER** remove guards or any other safety devices from your shaper.
- NEVER** use dull or damaged knives.
- NEVER** force the cut or overload the shaper.
- NEVER** change cutters or knives or make adjustments with the shaper plugged in.
- NEVER** make adjustments to the shaper while the cutter is turning.

Rabbeting cutter head

new

694.100

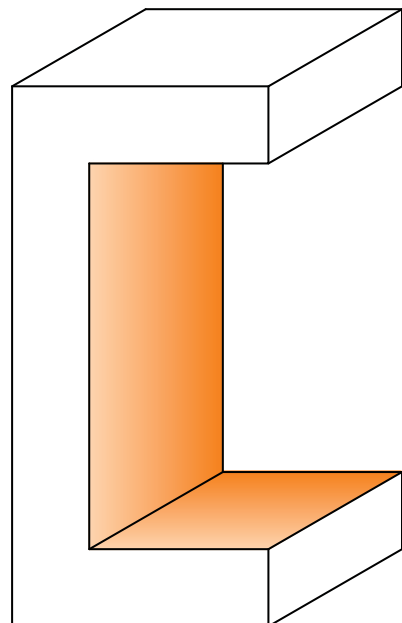

These rabbeting cutter heads have been designed for:
 -rabbeting, joining and grooving materials of various thicknesses.
 -ideal for coated and uncoated man made boards, plastic material and hard and soft wood.
 -Improved design with sheer angle.
 in your spindle moulder machines, double-end tenoner and edging machines. Perfect in all materials, but a better results in achieved using chipboard and MDF, wood composites, plastic materials and laminates.

Technical details:

- Heavy duty aircraft aluminum body
- 2 universal HWM straight knives 50x12x1,5mm [Z2]
- 4 universal HWM scoring knives 14x14x2mm [V4]
- Tools for manual feed MAN
- Pins for the automatic positioning 2" of the knives

- Supplied in a solid plastic box

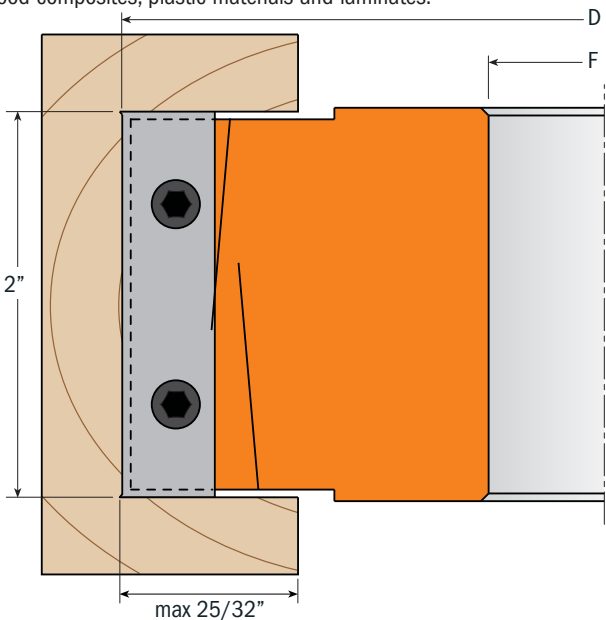

Order No.	Description	D_Cutting diameter		F_Bore diameter	
		inches	mm	inches	mm
694.100.19	Cutter head	4	100	3/4	19.05
694.100.30	Cutter head	4	100	1-3/16	30
694.100.31	Cutter head	4	100	1-1/4	31.75
spare parts:					
790.500.00	HWM Knives 50x12x1,5mm				
790.140.00	HWM Knives 14x14x2mm				
695.999.46	Wedge for knives 46x11x9,5mm				
990.064.00	Screw M8x16				
990.080.00	Screw Torx M5x6,5				

Drawings are 1:1 scale

694.001



These cutter heads are the ideal tools to create precision slots and grooves in materials from 4 to 15mm in depth by using the CMT 3 piece adjustable grooving set. This set includes:

- 2 cutter heads type (A) Z4 + V4
- 1 cutter head type (B) Z2
- 12 spacer rings from 0,1 to 2mm

Perfect grooving in all materials, but ideal on solid woods, plywood and laminated panels.

Technical details:

- Super-strength steel body
- 2 HWM Knives 7,65x12x1,5mm [Z2]
- 4 HWM Knives 18x18x1,5mm [Z4]
- 4 HWM Knives 14x14x1,2mm [V4]
- Tools for manual feed MAN
- Pins for the automatic positioning of the knives

- Supplied in a solid plastic box

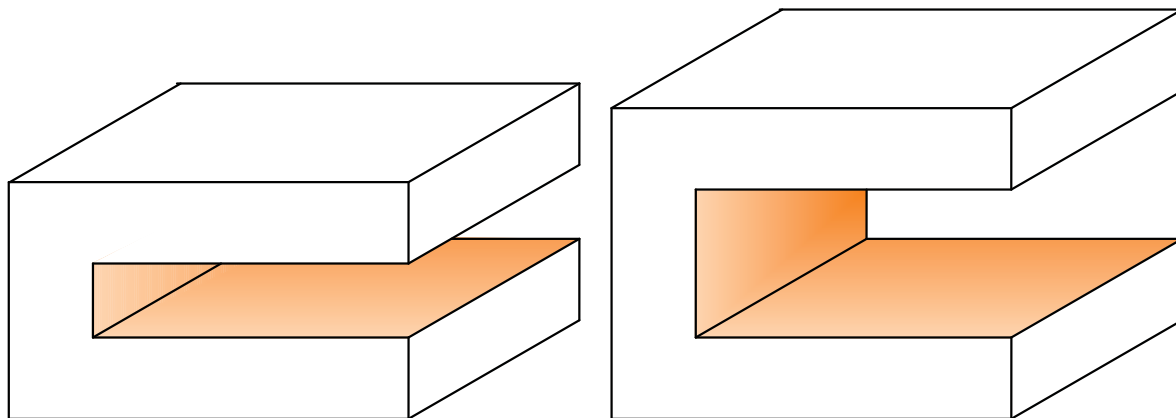
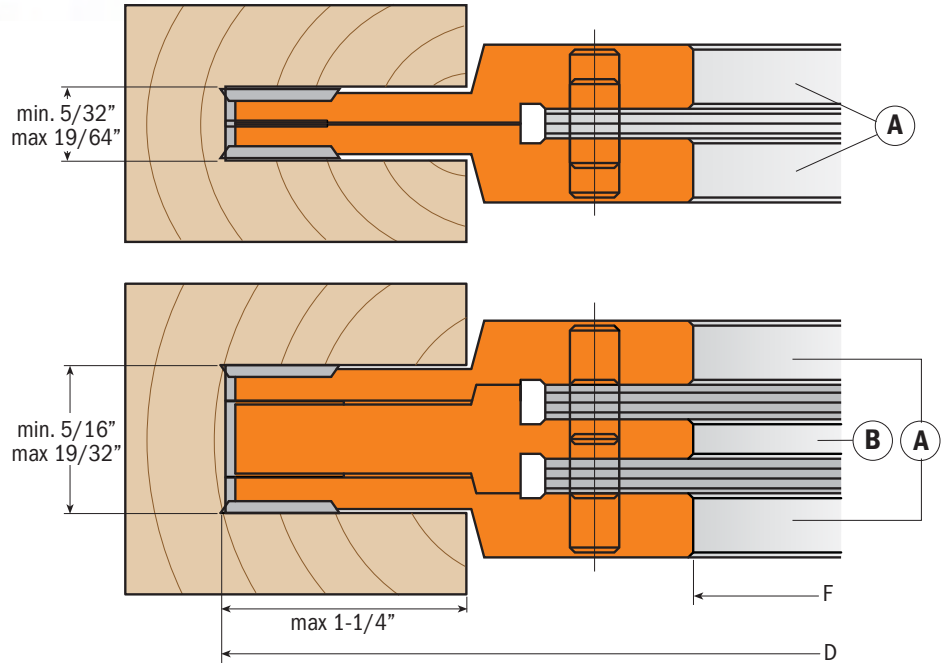

Drawings are 1:1 scale

Order No.	Description	D_Cutting diameter		F_Bore diameter	
		inches	mm	inches	mm
694.001.31	Cutter head	5-1/2	140	1-1/4	31,75
spare parts: For cutter heads (A)					
790.181.00	HWM Knives				
990.079.00	Screw Torx M4x3,2mm				
695.996.02	Threaded ring M4				
790.140.10	HWM Knives				
695.996.01	Threaded ring M4				
For cutter heads (B)					
790.076.00	HWM Knives				
695.999.07	Wedge for knives				
990.063.00	Screw M5x18mm				
695.998.22	Spacers set bore 1-1/4"				

45° Chamfer cutter head

new

CMT ORANGE TOOLS™

694.002



CMT Chamfer cutter heads cut clean, accurate bevels, chamfers and joints that are great for edge work. Excellent results in most materials but ideal on solid wood, veneer board and laminated materials.

Technical details:

- Heavy duty aircraft aluminum body
- 2 HWM Knives 50x12x1,5mm [Z2]
- Tools for manual feed MAN
- Pins for the automatic positioning of the knives.

Supplied in a solid plastic box

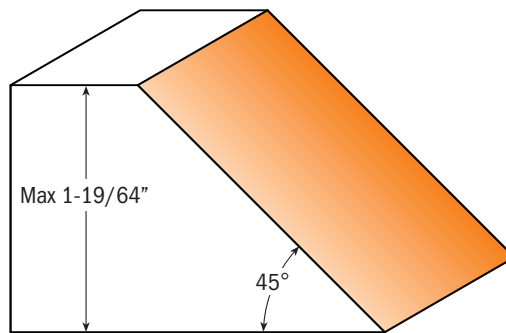
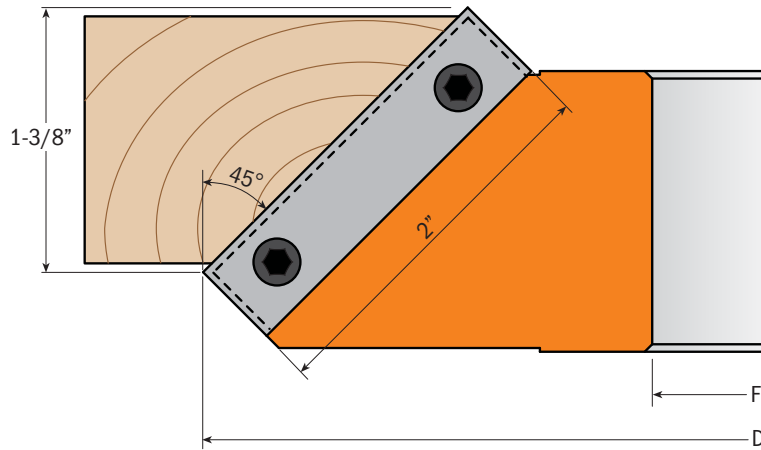
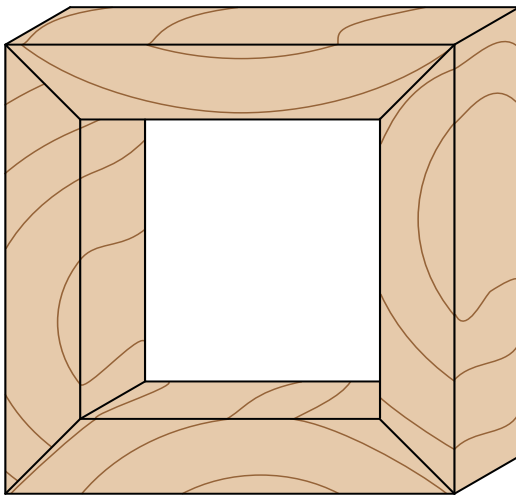

Drawings are 1:1 scale

Order No.	Description	D_Cutting diameter		F_Bore diameter	
		inches	mm	inches	mm
694.002.31	Cutter head	5-7/8	150	1-1/4	31,75
spare parts:	790.500.00	HWM Knives			
	695.999.41	Wedge for knives			
	990.086.00	Screw M8x20mm			

694.005



The CMT adjustable rounding and chamfering set is a two piece set which are easy to set up in your shaper. The system allows you to roundover both top and bottom edges in one pass with a radius of 2,3,4,5 and 6mm and it allows 45 degree chamfering in material from 18mm to 50mm thick. The improved design with sheer angle guarantees a perfect finish.

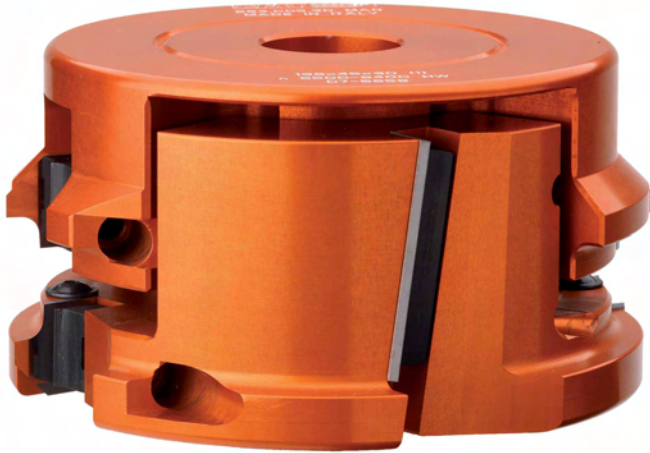

Technical details:

- Heavy duty aircraft aluminum body
- One pair of HWM top knives radius 4mm and 45° chamfer (20x20,5x2mm) [Z2]
- One pair of HWM bottom knives radius 4mm and 45° chamfer (20x20,5x2mm) [Z2]
- Two HWM knives 50x12x1,5mm
- Set of 21 spacer rings from 0,1 to 3mm
- Tools for manual feed MAN
- Pins for the automatic positioning of the knives

Supplied in a solid plastic box

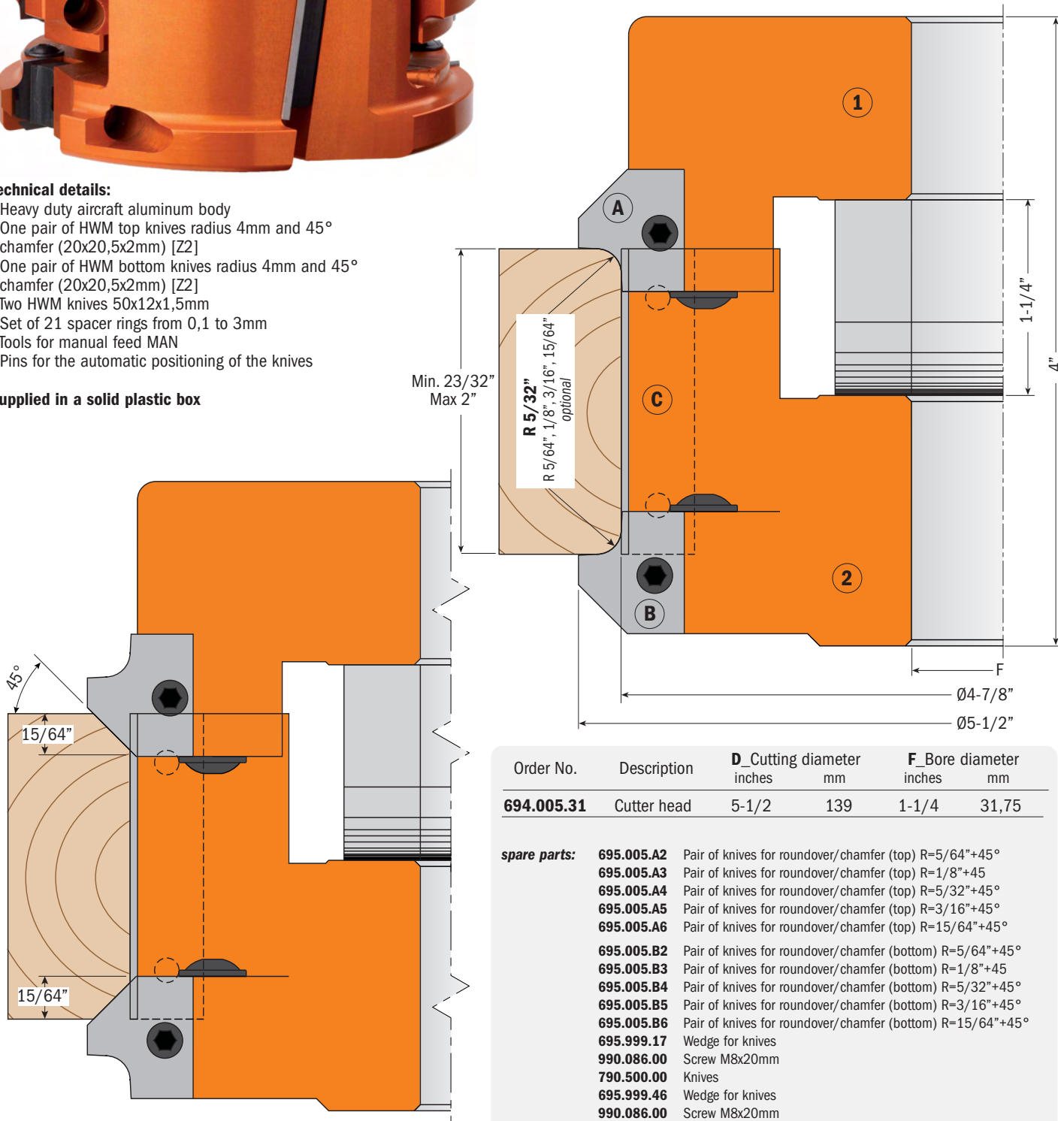

Order No.	Description	D_Cutting diameter		F_Bore diameter	
		inches	mm	inches	mm
694.005.31	Cutter head	5-1/2	139	1-1/4	31,75

spare parts:

695.005.A2	Pair of knives for roundover/chamfer (top) R=5/64"+45°
695.005.A3	Pair of knives for roundover/chamfer (top) R=1/8"+45°
695.005.A4	Pair of knives for roundover/chamfer (top) R=5/32"+45°
695.005.A5	Pair of knives for roundover/chamfer (top) R=3/16"+45°
695.005.A6	Pair of knives for roundover/chamfer (top) R=15/64"+45°
695.005.B2	Pair of knives for roundover/chamfer (bottom) R=5/64"+45°
695.005.B3	Pair of knives for roundover/chamfer (bottom) R=1/8"+45°
695.005.B4	Pair of knives for roundover/chamfer (bottom) R=5/32"+45°
695.005.B5	Pair of knives for roundover/chamfer (bottom) R=3/16"+45°
695.005.B6	Pair of knives for roundover/chamfer (bottom) R=15/64"+45°
695.999.17	Wedge for knives
990.086.00	Screw M8x20mm
790.500.00	Knives
695.999.46	Wedge for knives
990.086.00	Screw M8x20mm
695.998.22	Spacers set bore 1-1/4"

Drawings are 1:1 scale

Multiradius roundover cutter head

new

CMT ORANGE TOOLS™

694.003

MAN

Z2



Innovative cutter heads supporting three different knives making six radius roundover profiles. The standard cutter heads is delivered with knives radius 5 and 10mm; two more knives sets are available to make radius 4-8mm and 3-6mm. Perfect in all materials, but ideal on solid woods and panel materials.

Technical details:

- Heavy duty aircraft aluminum body.
- 2 HWM knives radius 5/10mm (25x24,8x2mm) [Z2]
- Tools for manual feed MAN
- Pins for the automatic positioning of the knives

Supplied in a solid plastic box



STANDARD

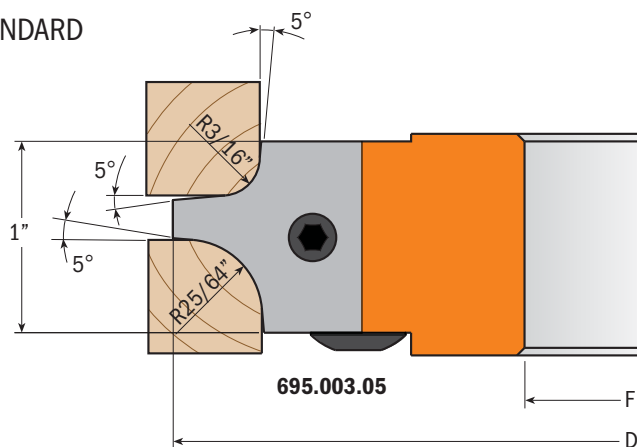

OPTIONAL

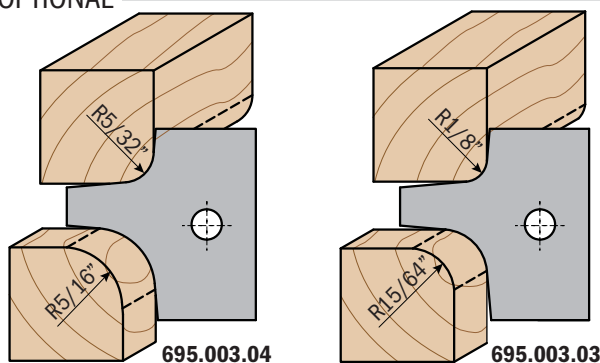

Drawings are 1:1 scale

Order No.	Description	D_Cutting diameter		F_Bore diameter	
		inches	mm	inches	mm
694.003.31	Cutter head	4-1/2	113	1-1/4	31,75
spare parts:	695.003.05	Pair of profiled knives R=3/16" and 25/64"			
	695.003.04	Pair of profiled knives R=5/32" and 5/16"			
	695.003.03	Pair of profiled knives R=1/8" and 15/64"			
	695.999.22	Wedge for knives			
	990.086.00	Screw M8x20mm			

694.004



Innovative cutter heads supporting two different knives making four radius roundover profiles. The standard cutter head is delivered with knives radius 15 and 20mm; one more knives set is available to make radius 12-18mm. Excellent results in most materials but ideal on solid wood and coated and uncoated man made materials.

Technical details:

- Heavy duty aircraft aluminum body.
- 2 HWM knives radius 15/20mm (45x34,5x2mm) [Z2]
- Tools for manual feed MAN
- Pins for the automatic positioning of the knives

Supplied in a solid plastic box

STANDARD

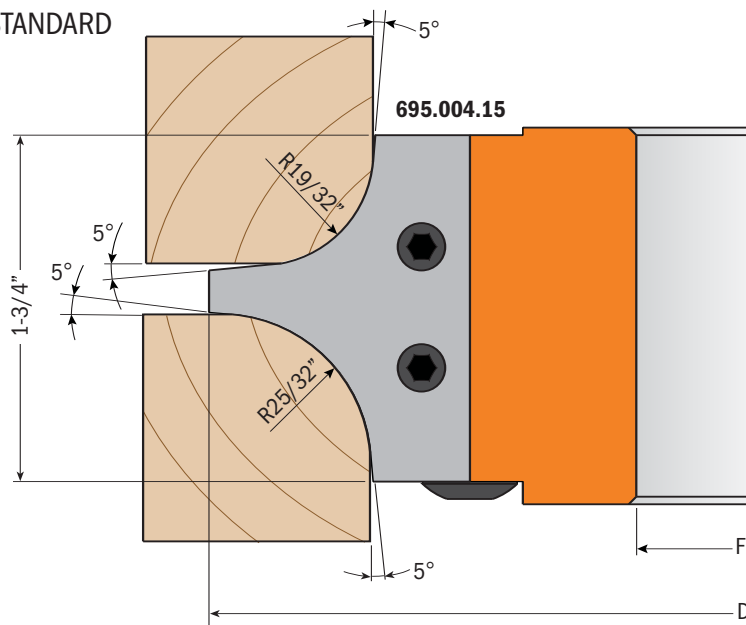

OPTIONAL

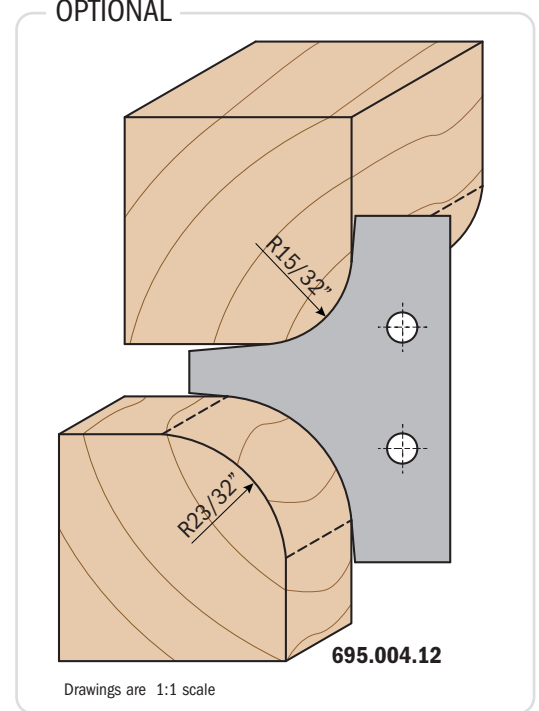

Drawings are 1:1 scale

Order No.	Description	D_Cutting diameter		F_Bore diameter	
		inches	mm	inches	mm
694.004.31	Cutter head	5-1/4"	132	1-1/4	31,75
spare parts:	695.004.15	Pair of profiled knives R=19/32" and 25/32"			
	695.004.12	Pair of profiled knives R=15/32" and 23/32"			
	695.999.42	Wedge for knives			
	990.086.00	Screw M8x20mm			

Roundover and cove cutter head

new

CMT ORANGE TOOLS™

694.007

MAN

Z2



This cutter head is the perfect tool to make furniture, doors, and drawer fronts that go from simple to elegant by giving them a final touch with a CMT cove bit. Use together with roundover profile and construct perfectly fitting rule joints that are ideal for drop leaf counter and table tops.

It supports three different knives making roundover and cove profiles radius 10, 12 and 15mm.

To be used in your spindle moulder machines, double-end tenoners and shapers machines.

Perfect in all materials, but ideal on solid woods and panel materials.



Technical details:

- Heavy duty aircraft aluminum body.
- 2 HWM knives radius 10mm (34,8x29,3x2mm) [Z2]
- Tools for manual feed MAN
- Pins for the automatic positioning of the knives

Supplied in a solid plastic box

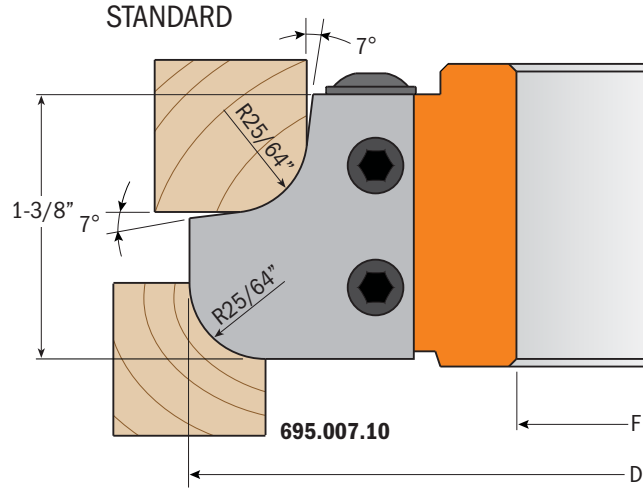

OPTIONAL

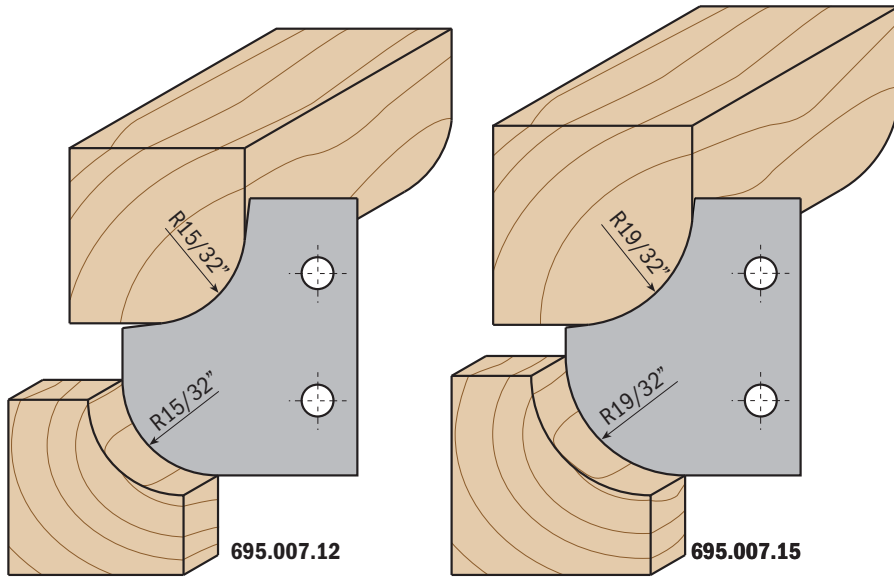

Order No.	Description	D_Cutting diameter		F_Bore diameter	
		inches	mm	inches	mm
694.007.31	Cutter head	4-3/4	121	1-1/4	31,75
spare parts:	695.007.10	Pair of knives roundover/cove R=25/64"			
	695.007.12	Pair of knives roundover/cove R=15/32"			
	695.007.15	Pair of knives roundover/cove R=19/32"			
	695.999.31	Wedge for knives			
	990.086.00	Screw M8x20mm			

694.008

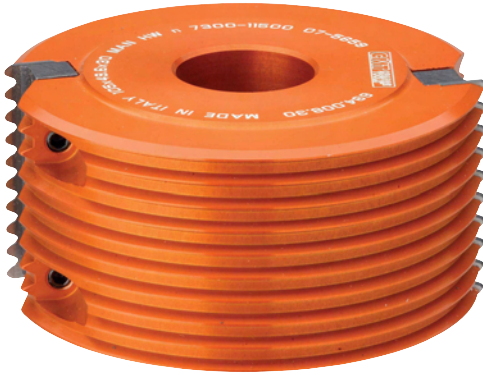

The professional CMT finger joint cutter head lets you make one of the most incredibly strong side-to-side joints in all wood and wood composites.

The tightness of the accurately cut joint and the maximum glue surface create a joint that is actually stronger than an unworked piece of wood, in stock with max thickness of 47mm. Ideal for molding manufacturers and furniture makers.

Excellent results in most materials but ideal on solid wood and coated and uncoated man made material.

Technical details:

- Heavy duty aircraft aluminum body.
- 2 HWM knives 49,6x11,9x1,5mm [Z2]
- Tools for manual feed MAN
- Pins for the automatic positioning of the knives

Supplied in a solid plastic box

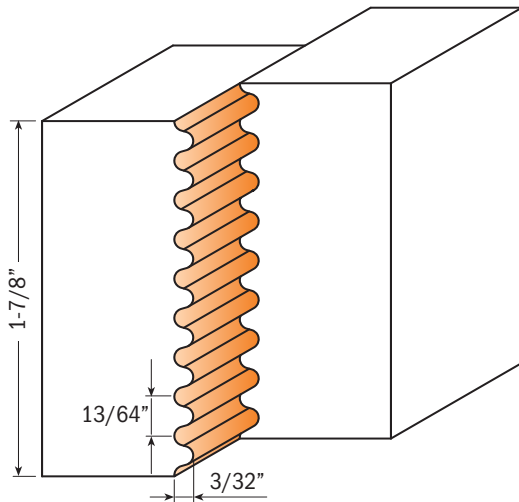

Drawings are 1:1 scale

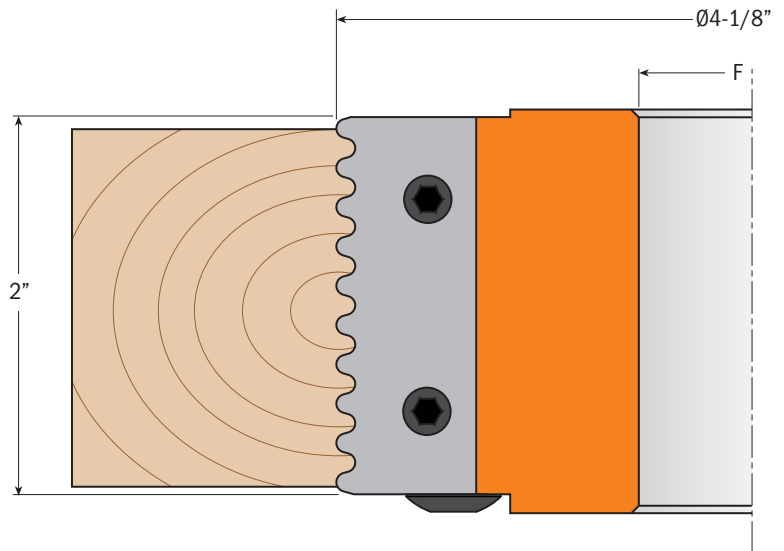

Order No.	Description	D_Cutting diameter		F_Bore diameter	
		inches	mm	inches	mm
694.008.31	Cutter head	4-1/8	105	1-1/4	31,75
spare parts:					
695.008.01	Pair of knives for finger joint				
695.999.49	Wedge for knives				
990.066.00	Screw M6x16mm				
695.998.2631	Guide ring with bore 1-1/4"				

Reverse glue joint cutter head

new

CMT ORANGE TOOLS™

694.009



The most unique and important feature of this CMT cutter head is its capacity to produce an almost indestructible glue joint quickly and without error. Ideal for shaping wide dimension panels, doors and furniture pieces. By accurately centering the cutter head to the wood, the upper and lower vertical cutting edges will cut equal proportions. Simply run one edge of the panel, turn the panel over, and then run the opposite edge - you will produce perfectly harmonized reverse cuts that match up to make flawless joints. Excellent results in most materials but ideal on solid wood and coated and uncoated man made materials.

Technical details:

- Heavy duty aircraft aluminum body.
- 2 HWM knives 40x18x2mm [Z2]
- Tools for manual feed MAN
- Pins for the automatic positioning of the knives

Supplied in a solid plastic box

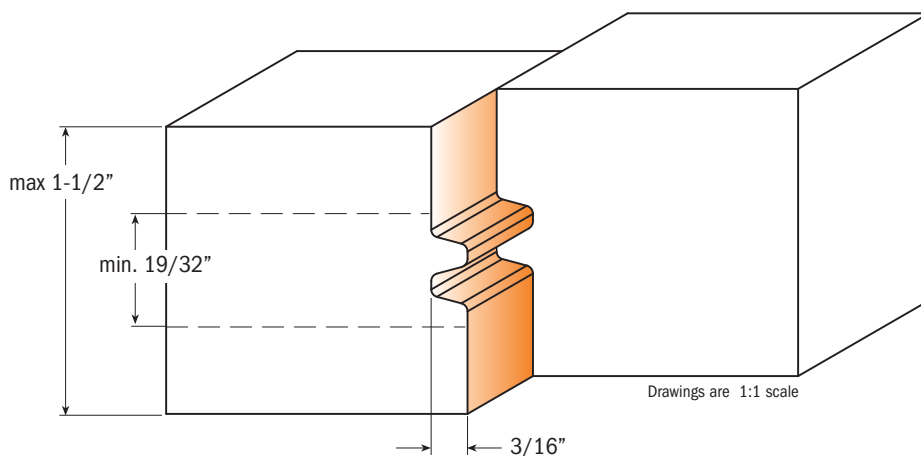
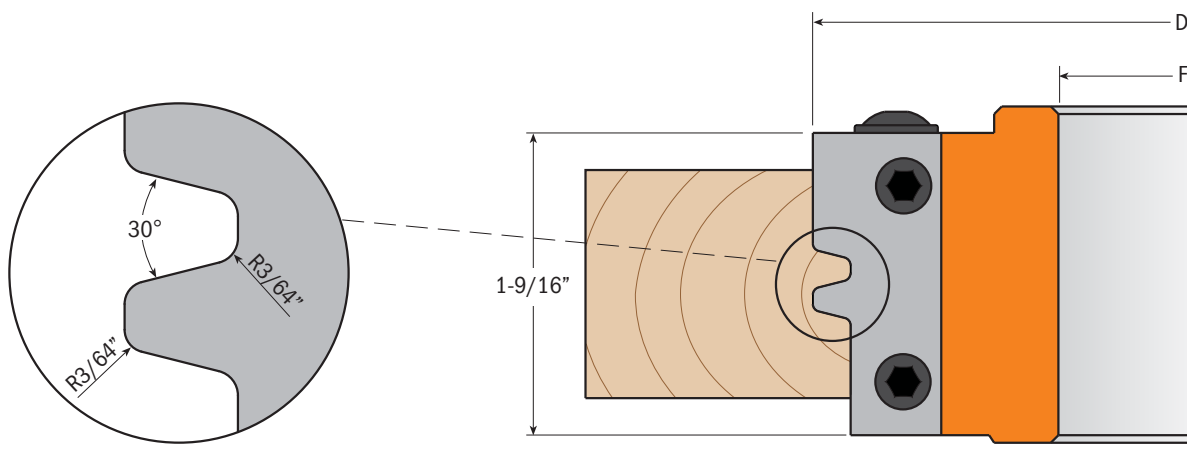

Order No.	Description	D_Cutting diameter		F_Bore diameter	
		inches	mm	inches	mm
694.009.31	Cutter head	4	100	1-1/4	31,75
spare parts:	695.009.01 Pair of knives for glue joint				
	695.999.38 Wedge for knives				
	990.086.00 Screw M8x20mm				

694.011



CMT lock miter cutter heads bits are ideal for milling miter joints in max 29mm stock. The quick and easy way to accurately create boxes, stretcher bars, frames and any assortment of right angle or parallel joint projects.

The lock miter cutter head produces perfectly fitting 45 degree miter joints in two steps. First, make the cut with the workpiece in the horizontal position then make the cut with the workpiece in the vertical position. By cutting boards in the horizontal position - first with the inside face down and then with the inside face up - you can mill rock solid parallel glue joints.

Excellent results in most materials but ideal in solid wood and in coated and uncoated man made materials.

Technical details:

- Heavy duty aircraft aluminum body
- 2 HWM knives 40x18x2mm [Z2]
- Tools for manual feed MAN
- Pins for the automatic positioning of the knives

Supplied in a solid plastic box

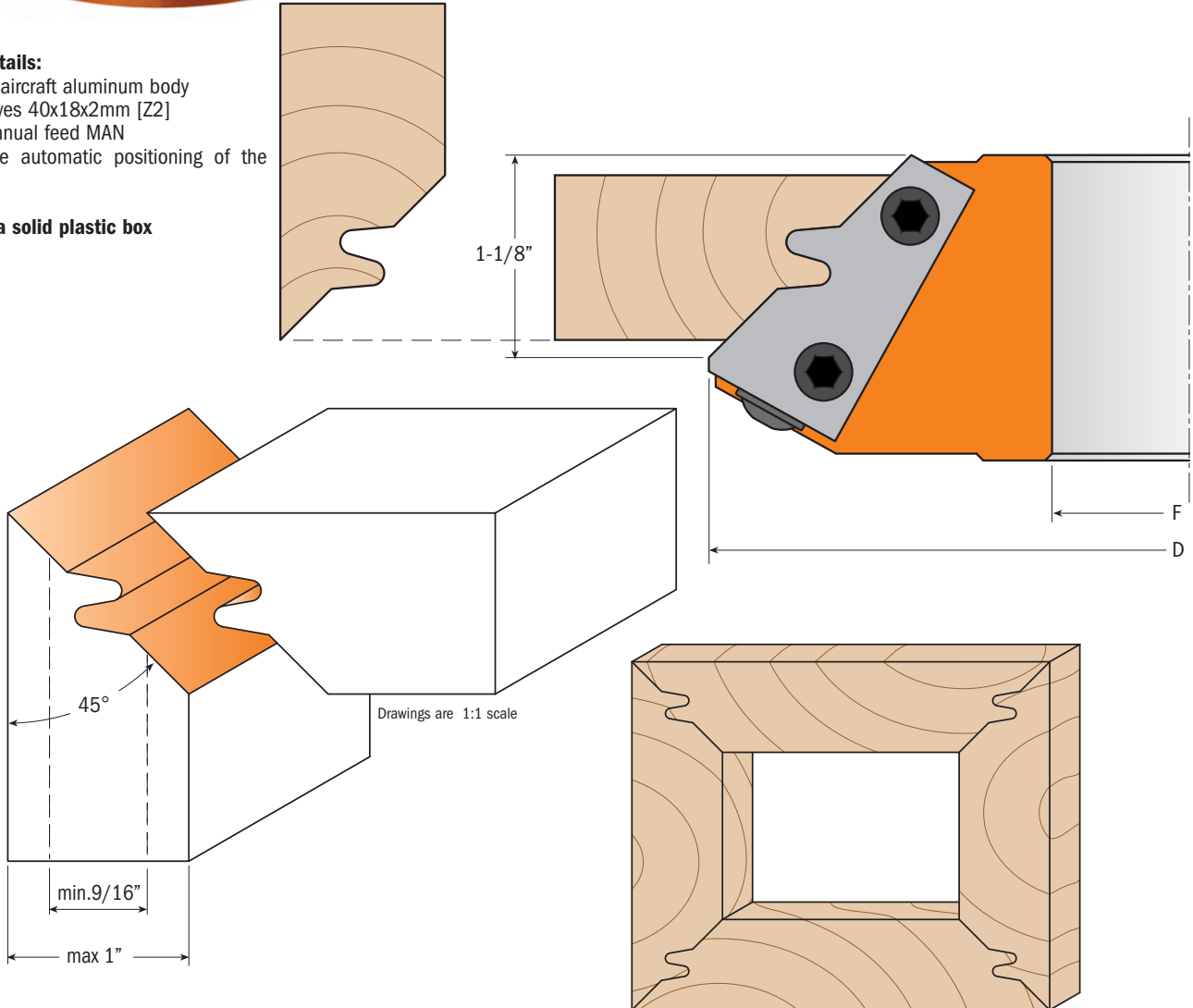

Order No.	Description	D_Cutting diameter		F_Bore diameter	
		inches	mm	inches	mm
694.011.31	Cutter head	5-1/2	140	1-1/4	31,75
spare parts:	695.011.01	Pair of knives for lock miter			
	695.999.42	Wedge for knives			
	990.086.00	Screw M8x20mm			

694.013



We offer you the traditional approach to panel construction with the CMT raised panel cutter head. Make your classic raised panels on furniture, interior and cabinet doors in solid wood and wooden boards, obtaining three different profiles adjusting the cutting depth. Multiple passes are recommended to safely and accurately obtain the perfect finish. Excellent results in most materials but ideal for hardwood, soft wood and wooden veneer board.



Technical details:

- Heavy duty aircraft aluminum body
- 2 HWM Knives type (A) 19,8x11,9x1,5mm [Z2]
- 2 HWM Knives type (B) 60x11,9x1,5mm [Z2]
- Tools for manual feed MAN
- Pins for the automatic positioning of the knives

Supplied in a solid plastic box

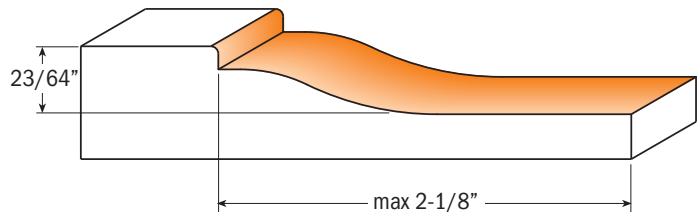
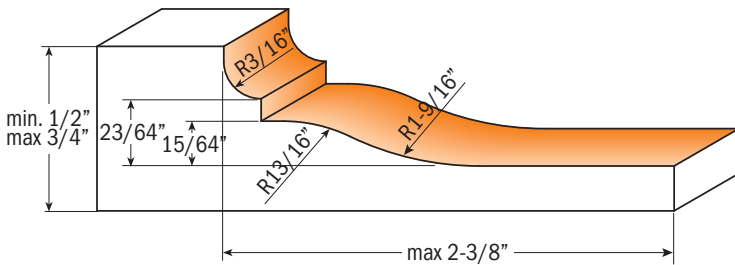
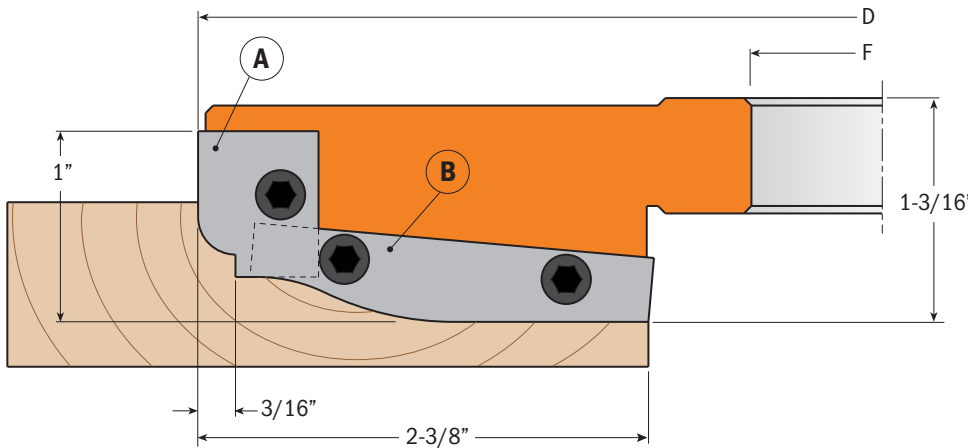

Drawings are 1:1 scale

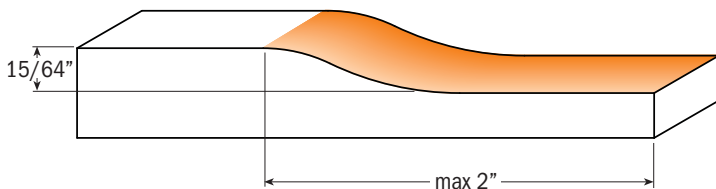

Order No.	Description	D_Cutting diameter		F_Bore diameter	
		inches	mm	inches	mm
694.013.31	Cutter head	7-1/4"	183	1-1/4	31,75
spare parts:					
695.013.A1	Pair of knives type (A) 19,8x11,9x1,5mm				
695.013.A2	Pair of knives type (B) 60x11,9x1,5mm				
695.999.16	Wedge for knives type (A) 16x11x9,5mm				
695.999.53	Wedge for knives type (B) 53x11x9,5mm				
990.085.00	Screw M6x25				

694.014



This cutter head represents the union of two cutters in one tool and it is the ideal tool head for the construction of furniture doors and drawers. By simply adjusting the height of the head, you can cut two perfectly joining profiles with no wasted time or effort. There is no need to move the fence or change the tool! Save money and have a more efficient production by investing in a single cutter head to produce stiles and rails. This is a perfect tool for solid wood and veneer panels for materials between 22mm and 25mm.

Technical details:

- Heavy duty aircraft aluminum body
- 2 HWM Knives type (A) 40x24,5x2mm [Z2]
- Tools for manual feed MAN
- Pins for the automatic positioning of the knives

Supplied in a solid plastic box

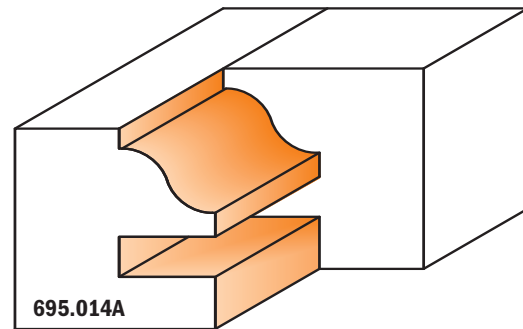
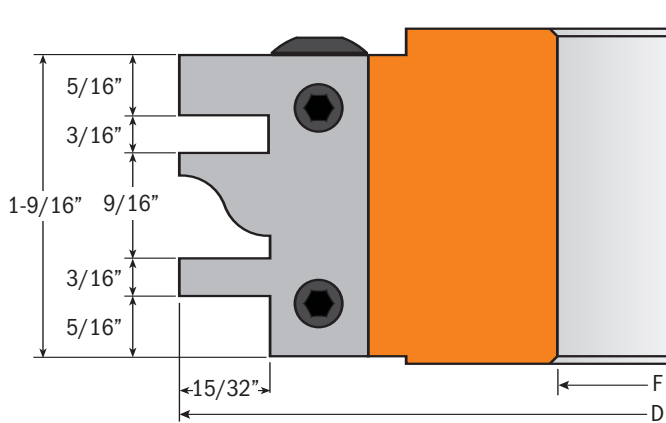

OPTIONAL

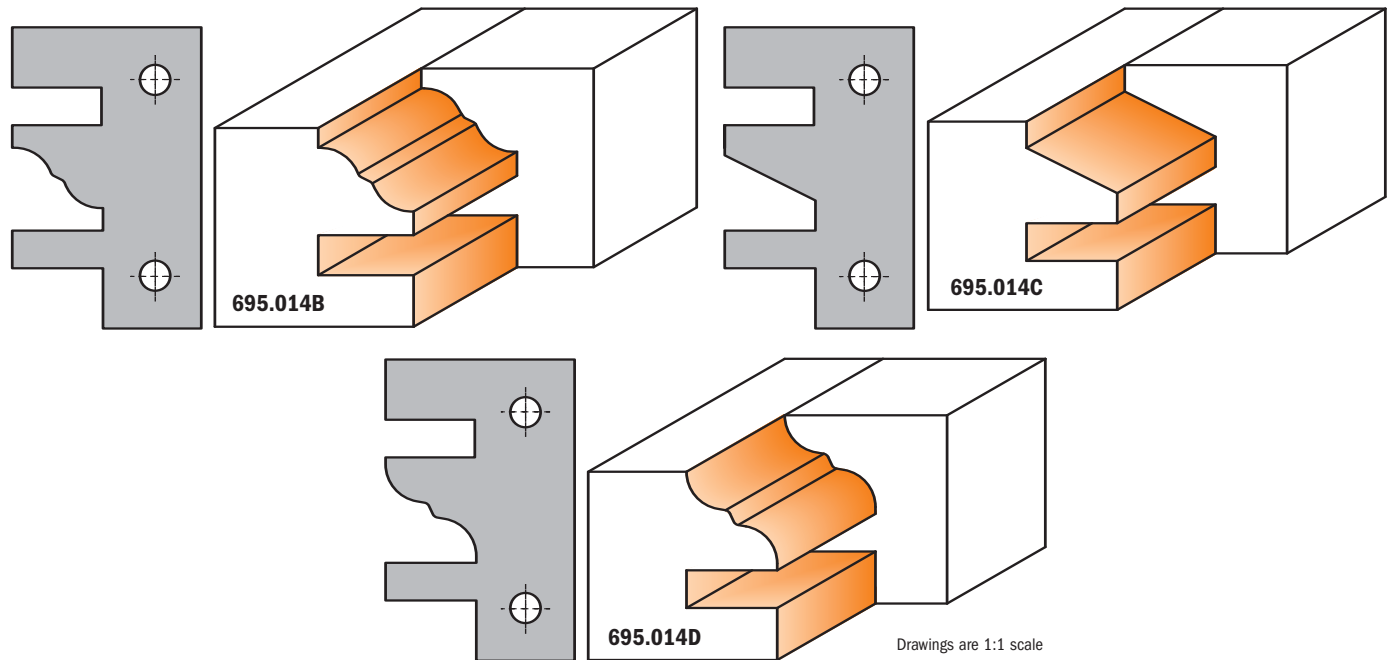

Drawings are 1:1 scale

Order No.	Description	D_Cutting diameter inches	mm	F_Bore diameter inches	mm
694.014.31	Cutter head	4-3/4"	120	1-1/4	31,75
spare parts:	695.014A	Pair of knives type			
	695.014B	Pair of knives type			
	695.014C	Pair of knives type			
	695.014D	Pair of knives type			
	695.999.39	Wedge for knives			
	990.085.00	Screw M6x25mm			

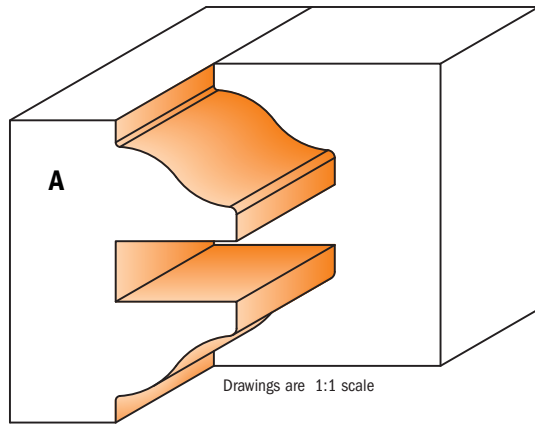

Drawings are 1:1 scale

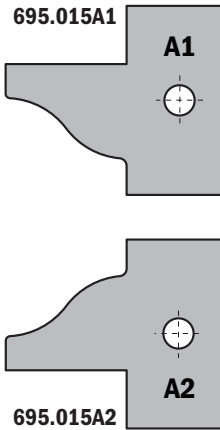

Technical details:

- Heavy duty aircraft aluminum body.
- Super-strength steel body for heads type (3)
- 2 HWM knives type (A1) 25x29,8x2mm [Z2]
- 2 HWM knives type (A2) 25x29,8x2mm [Z2]
- 2 HWM knives 7,65x12x1,5mm [Z2]
- 4 HWM knives 14x14x1,2mm [V4]
- 12 spacer rings from 0,1 to 3mm for heads type (1 & 2)
- 12 spacer rings from 0,1 to 2mm for heads type (3)
- Tools for manual feed MAN
- Pins for the automatic positioning of the knives

Supplied in a solid plastic box

OPTIONAL

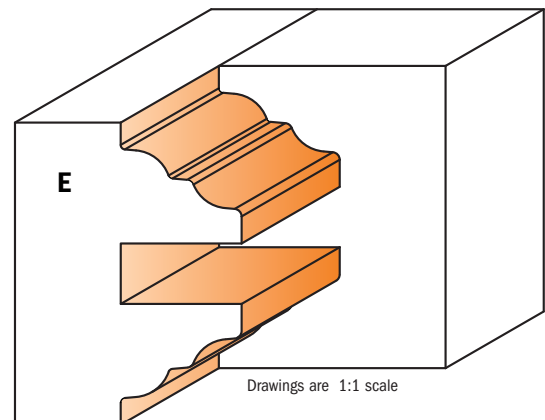
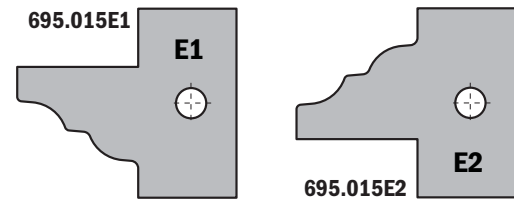
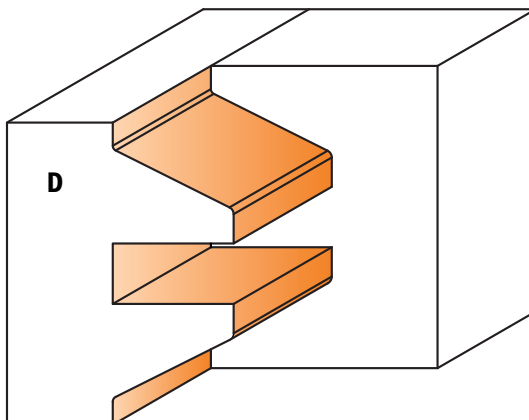
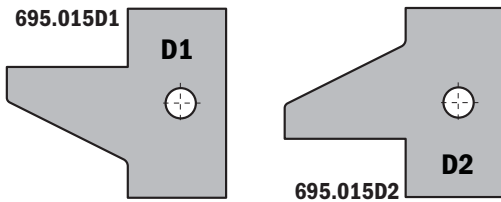
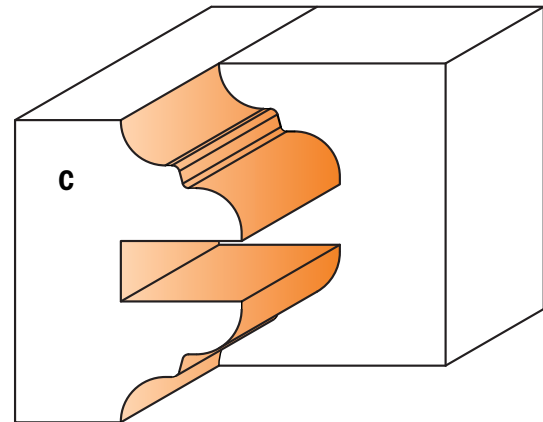
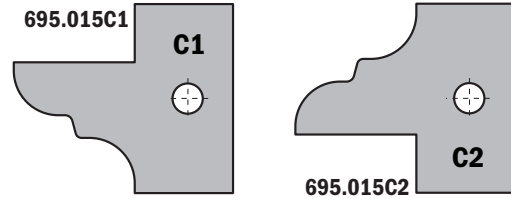
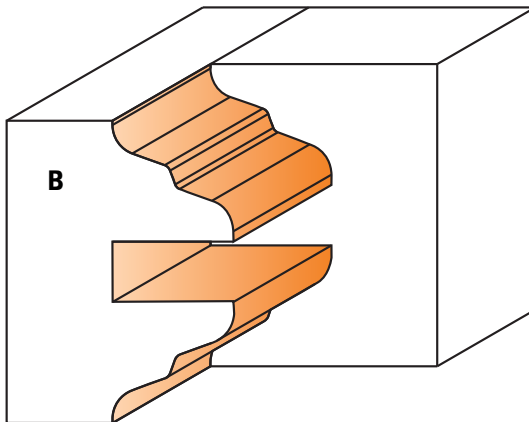
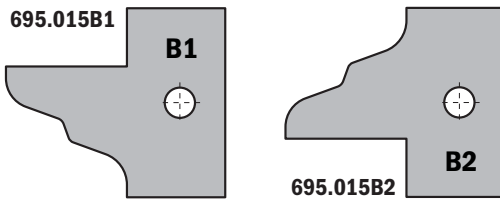

Drawings are 1:1 scale



692 MEC

CMT's new Cabinet & Joinery Shaper Set includes 13 profiles that are ideal for the professional woodworker. Selected primarily to make joints and doors, the profiles include raised panel and rail and stile cutters, tongue & groove and cove & bead cutters; plus several beautiful molding profiles.

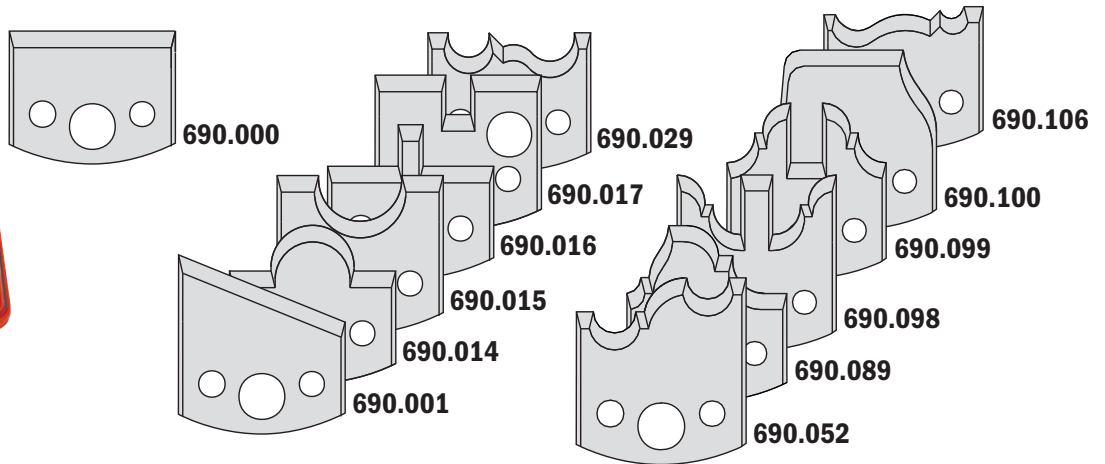

The set includes:

- Lightweight, aircraft-grade aluminum cutterhead
- 13 pairs of M2 steel knives with 40mm cutting height.
- Molded plastic case.

Order No.	Description	D_Cutting diameter inches	D_Cutting diameter mm	I_Cutting height mm	F_Bore diameter inches	F_Bore diameter mm
692.013.09	13 pcs. Cabinet and Joinery set	3-1/8	78	40	3/4	19.05
692.013.01	13 pcs. Cabinet and Joinery set	3-1/8	78	40	1-3/16	30
692.013.10	13 pcs. Cabinet and Joinery set	4	100	40	1	25.4
692.013.02	13 pcs. Cabinet and Joinery set	4	100	40	1-3/16	30
692.013.11	13 pcs. Cabinet and Joinery set	4	100	40	1-1/4	31.75

Molding & Profile Set



692 MEC

Our Molding and Profile Shaper Set includes 13 profiles that provide a great basic selection for almost any decorative molding need. The cutter head accepts any of the dozens of additional profiles listed on the following pages, so there's no limit to the shapes you can mill.

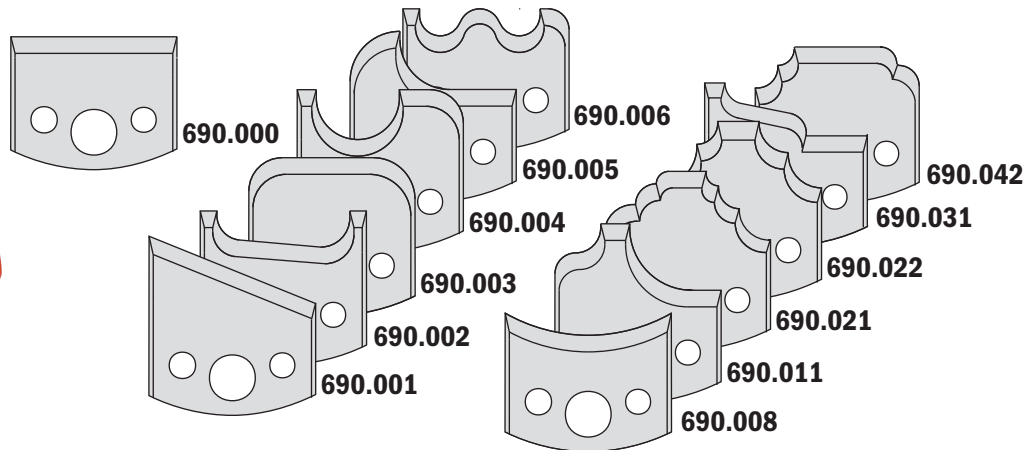

The set includes:

- Lightweight, aircraft-grade aluminum cutterhead
- 13 pairs of M2 steel knives with 40mm cutting height.
- Molded plastic case.

Order No.	Description	D_Cutting diameter inches	D_Cutting diameter mm	I_Cutting height mm	F_Bore diameter inches	F_Bore diameter mm
692.013.12	13 pcs. Molding and Profile set	3-1/8	78	40	3/4	19.05
692.013.05	13 pcs. Molding and Profile set	3-1/8	78	40	1-3/16	30
692.013.13	13 pcs. Molding and Profile set	4	100	40	1	25.4
692.013.06	13 pcs. Molding and Profile set	4	100	40	1-3/16	30
692.013.14	13 pcs. Molding and Profile set	4	100	40	1-1/4	31.75

CMT's high quality shaper cutterheads are the versatile, easy-to-use and cost effective solution to shaper work. Precision milled from the finest high-strength aluminum, these cutterheads feature dual pins to locate knives quickly and hold them securely. This cutter head includes a pair of straight knives, and accepts every knife set shown on the following pages. Use these tools on all types of shaper and spindle molder machines.

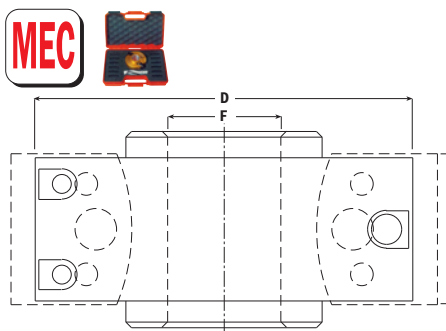

692



* For safety reasons we recommend the use of knives with a 40mm height only.

Order No. Aluminium body	Description	D_Cutting diameter inches mm	I_Cutting height mm	F_Bore diameter inches mm
692.078.19	Cutter head	3-1/8 78	40 or 50	3/4 19.05
692.078.30	Cutter head	3-1/8 78	40	1-3/16 30
692.100.26	Cutter head	4 100	40 or 50	1 25.4
692.100.30	Cutter head	4 100	40 or 50	1-3/16 30
692.100.31	Cutter head	4 100	40 or 50	1-1/4 31.75

spare parts: 692.999.01 Wedge for knives for 38x15x16mm
 990.064.00 M8x16mm screw
 991.064.00 4mm hex key

Technical details:

- Heavy duty aircraft aluminum body
- Pair of universal straight knives
- Tools for mechanical feed MEC
- Pins for the automatic positioning of the knives and the limitors
- Possibility to use knives with a height of 40mm or 50mm (order no. 690)
- **Solid plastic box to fit up to 12 couples of knives or limitors**

Spare Parts for cutter heads

Order No.	Description
692.999.01	Wedge for knife
990.064.00	Screw for wedge M8x16mm
694.999.01	Wedge for knife 48x8x12mm
990.066.00	Screw for wedge M6x16mm
990.067.00	Screw for scoring knife M5x8mm
991.064.00	4mm hex key
790.500.00	Carbide knives 50x12x1.5mm
790.140.00	Carbide knives 14x14x1.5mm

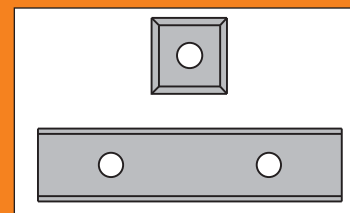
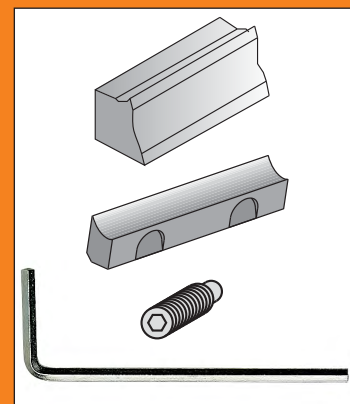

Bore Reducers

Order No. **699**

Order No.	Description
699.019.13	Pair of bore reducer 3/4" - 1/2"
699.026.19	Pair of bore reducer 1" - 3/4"
699.030.19	Pair of bore reducer 30mm - 3/4"
699.030.26	Pair of bore reducer 30mm - 1"
699.031.19	Pair of bore reducer 1-1/4" - 3/4"
699.031.26	Pair of bore reducer 1-1/4" - 1"
699.031.30	Pair of bore reducer 1-1/4" - 30mm



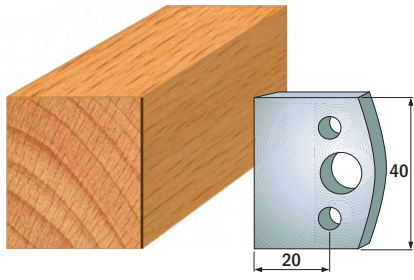

Pair of knives

690.000

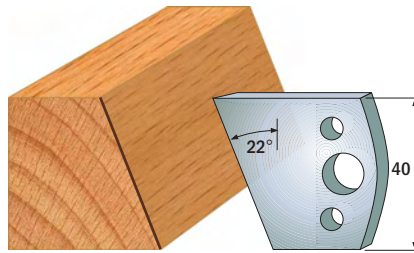

Pair of knives

690.001

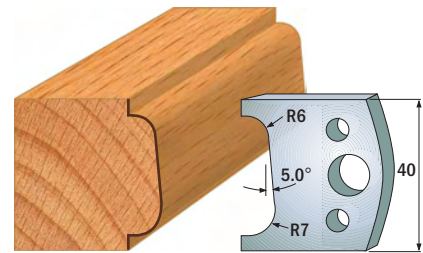

Pair of knives

690.002

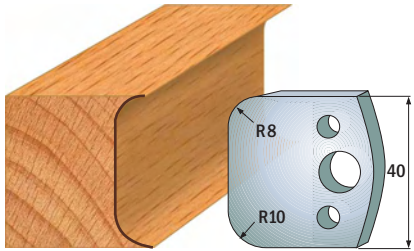

Pair of knives

690.003

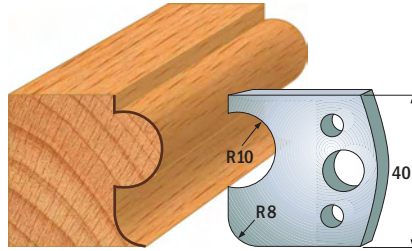

Pair of knives

690.004

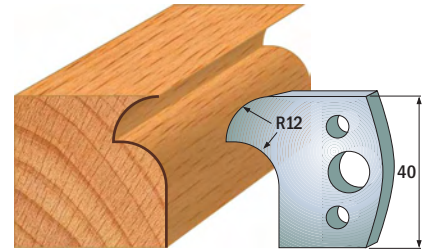

Pair of knives

690.005

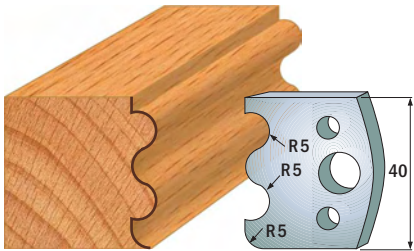

Pair of knives

690.006

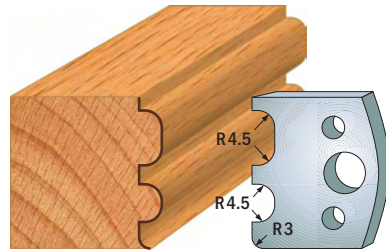

Pair of knives

690.007

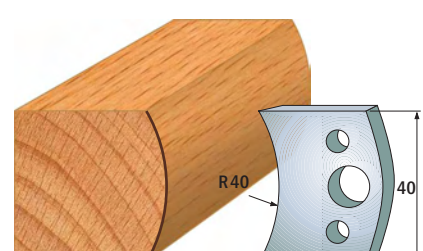

Pair of knives

690.008

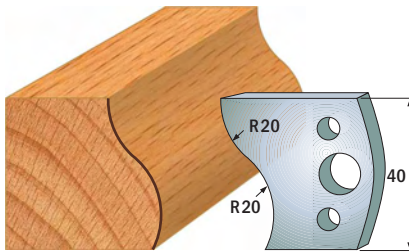

Pair of knives

690.009

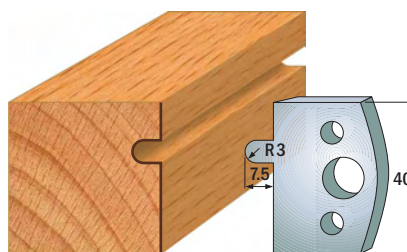

Pair of knives

690.010

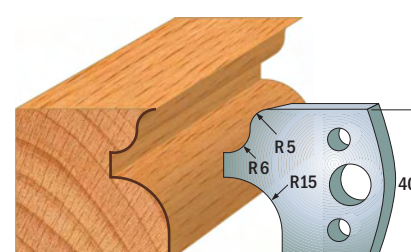

Pair of knives

690.011

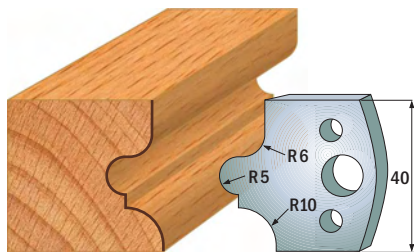

Pair of knives

690.012

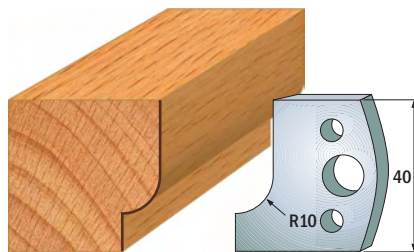

Pair of knives

690.013

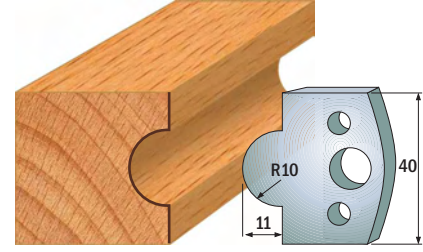

Pair of knives

690.014

Note: all knives and limitors only available in pairs

Drawings are 1:2 scale Dimensions inmm.

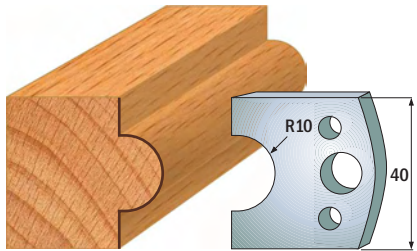

Pair of knives

690.015

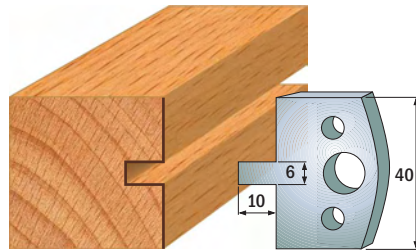

Pair of knives

690.016

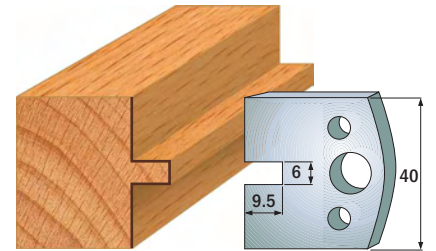

Pair of knives

690.017

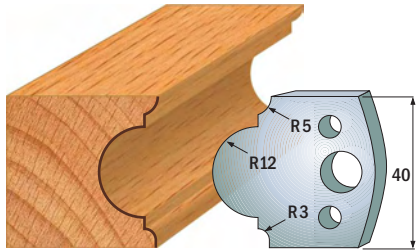

Pair of knives

690.018

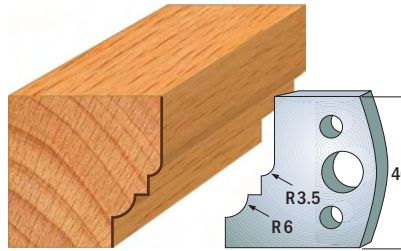

Pair of knives

690.019

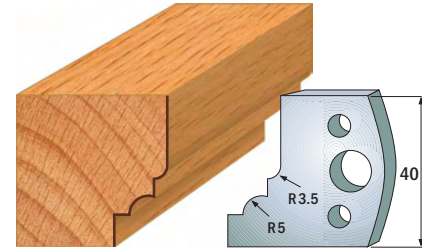

Pair of knives

690.020

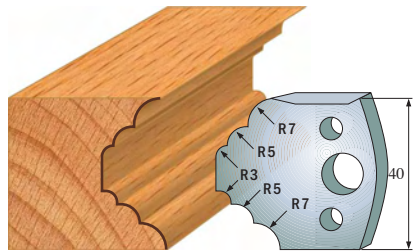

Pair of knives

690.021

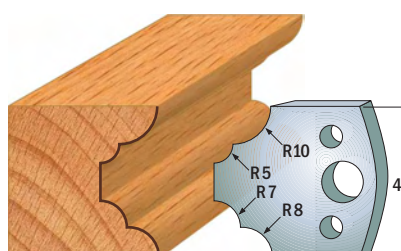

Pair of knives

690.022

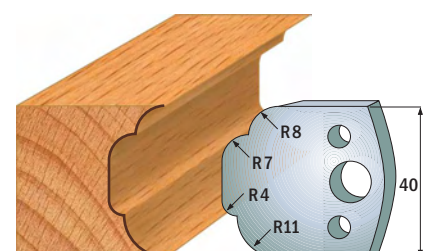

Pair of knives

690.023

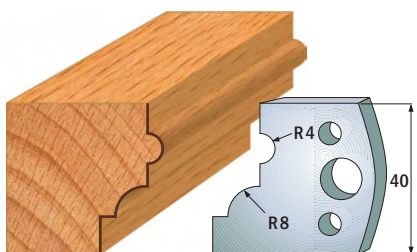

Pair of knives

690.024

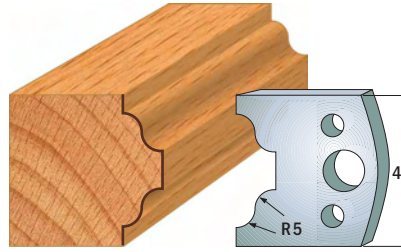

Pair of knives

690.025

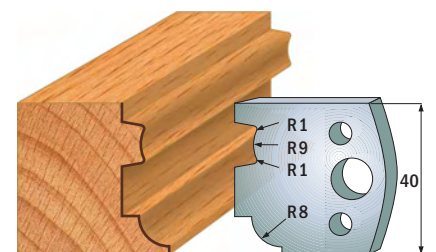

Pair of knives

690.026

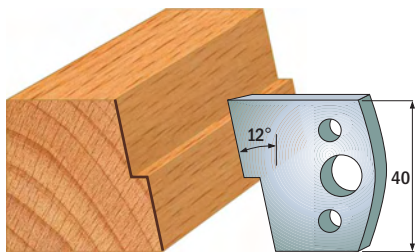

Pair of knives

690.027

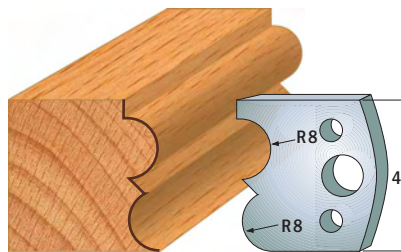

Pair of knives

690.028

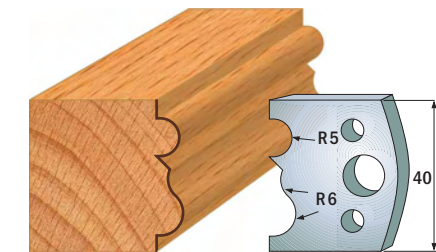

Pair of knives

690.029

Note: all knives and limitors only available in pairs

Drawings are 1:2 scale Dimensions inmm.

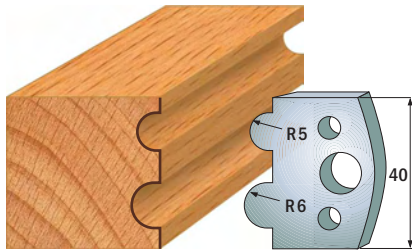

Pair of knives

690.030

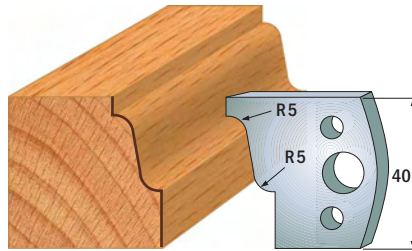

Pair of knives

690.031

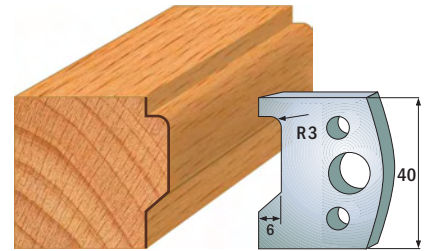

Pair of knives

690.032

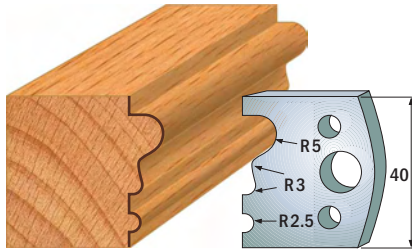

Pair of knives

690.033

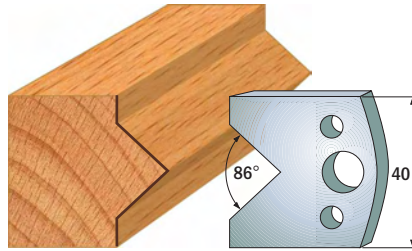

Pair of knives

690.034

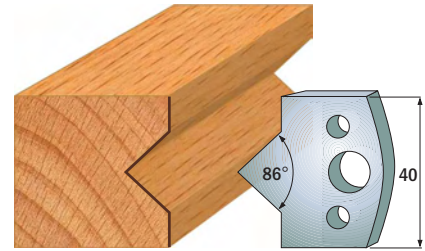

Pair of knives

690.035

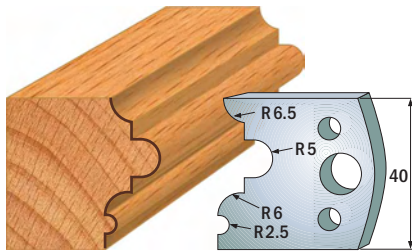

Pair of knives

690.036

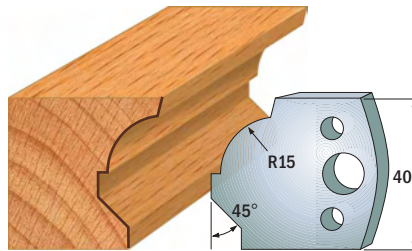

Pair of knives

690.037

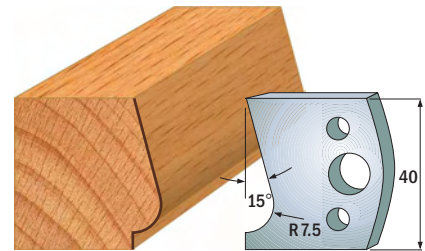

Pair of knives

690.038

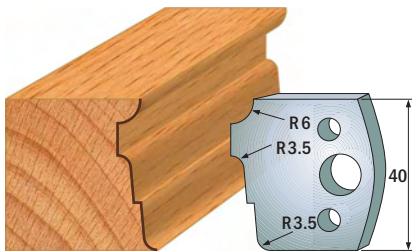

Pair of knives

690.039

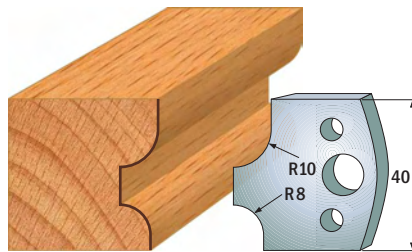

Pair of knives

690.040

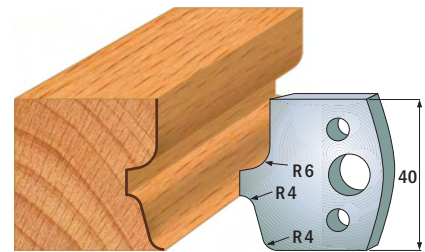

Pair of knives

690.041

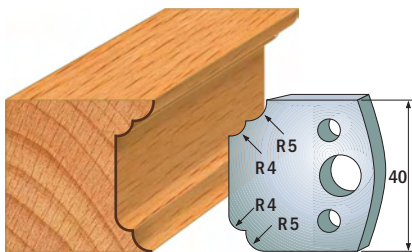

Pair of knives

690.042

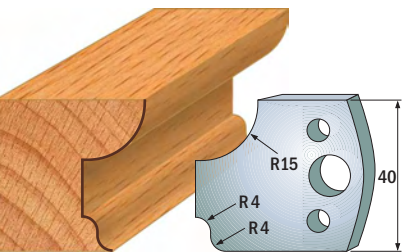

Pair of knives

690.043

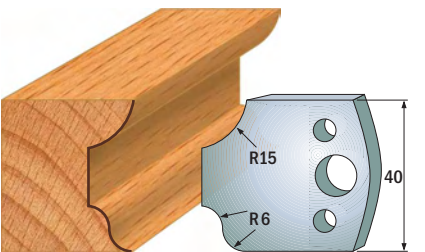

Pair of knives

690.044

Note: all knives and limitors only available in pairs

Drawings are 1:2 scale Dimensions inmm.

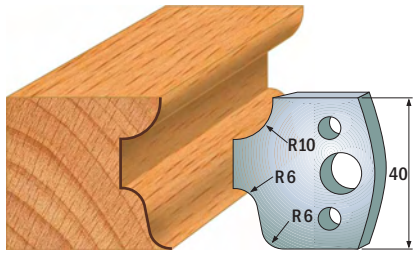

Pair of knives **690.045**

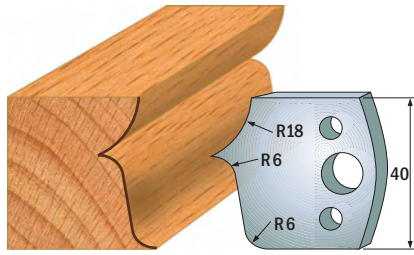

Pair of knives **690.046**

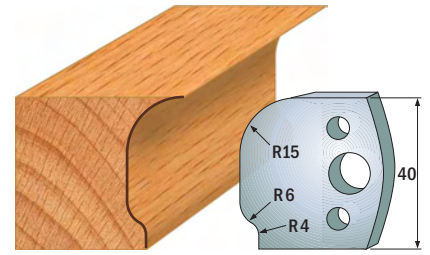

Pair of knives **690.047**

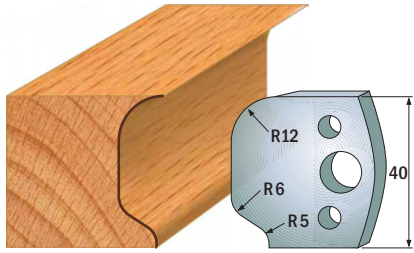

Pair of knives **690.048**

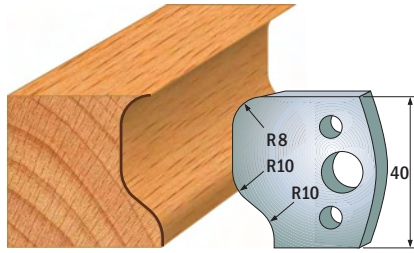

Pair of knives **690.049**

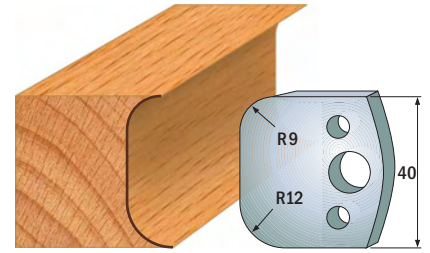

Pair of knives **690.050**

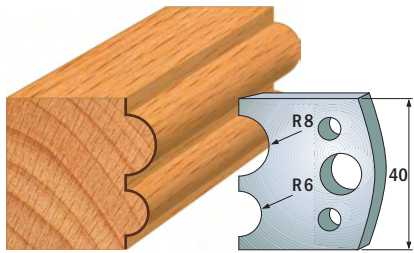

Pair of knives **690.051**

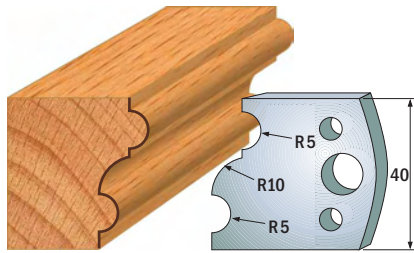

Pair of knives **690.052**

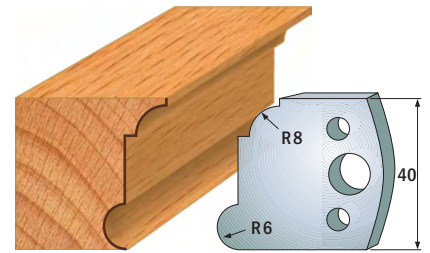

Pair of knives **690.053**

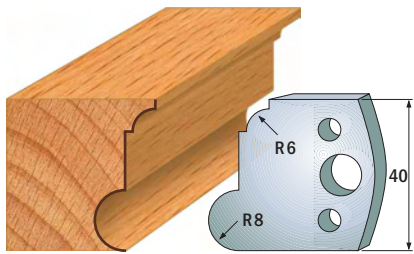

Pair of knives **690.054**

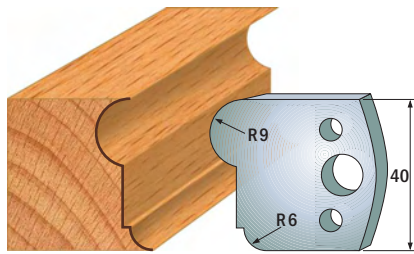

Pair of knives **690.055**

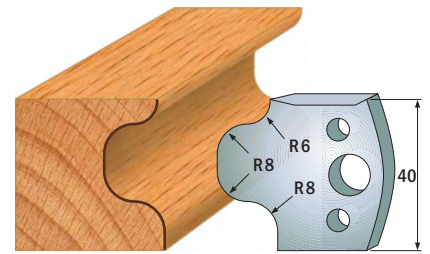

Pair of knives **690.056**

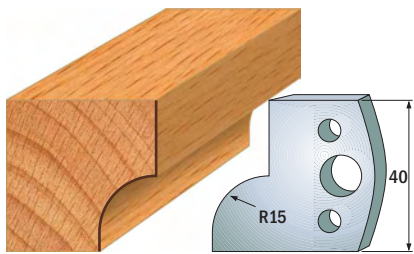

Pair of knives **690.057**

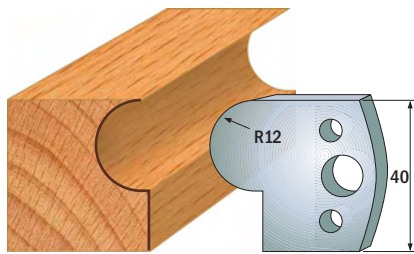

Pair of knives **690.058**

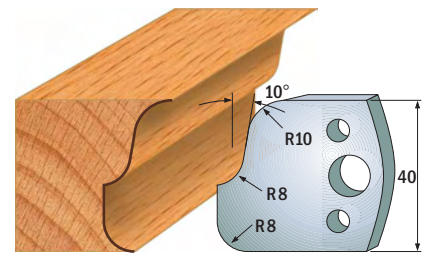

Pair of knives **690.059**

Note: all knives and limitors only available in pairs

Drawings are 1:2 scale Dimensions inmm.

Profile Knives for the Insert Shaper System

40mm high

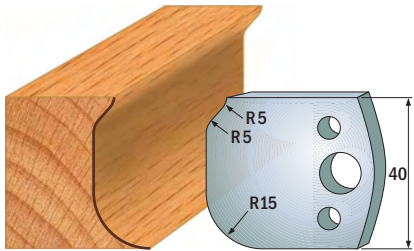

Pair of knives **690.060**

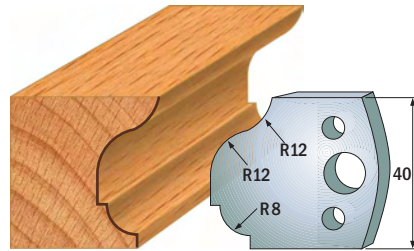

Pair of knives **690.061**

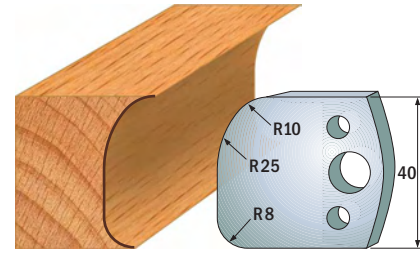

Pair of knives **690.062**

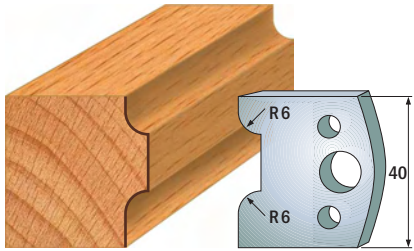

Pair of knives **690.063**

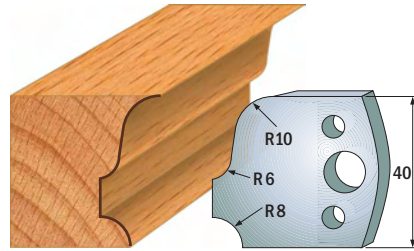

Pair of knives **690.064**

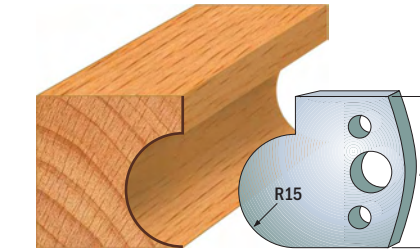

Pair of knives **690.065**

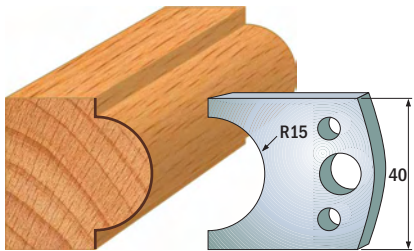

Pair of knives **690.066**

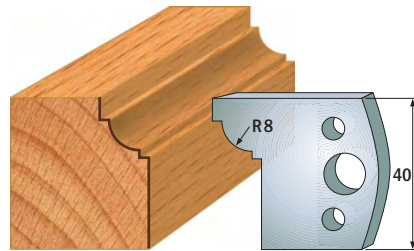

Pair of knives **690.067**

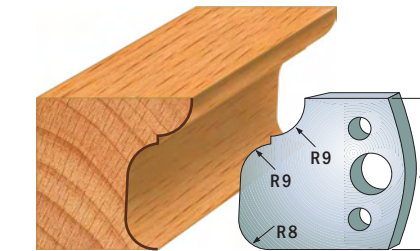

Pair of knives **690.068**

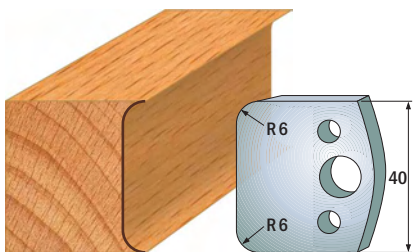

Pair of knives **690.069**

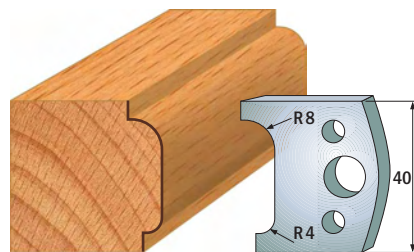

Pair of knives **690.070**

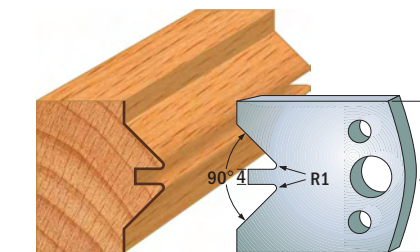

Pair of knives **690.071**

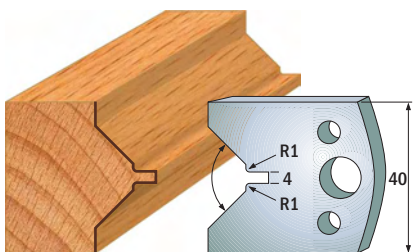

Pair of knives **690.072**

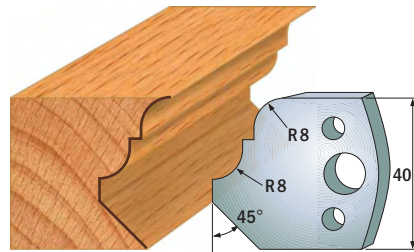

Pair of knives **690.073**

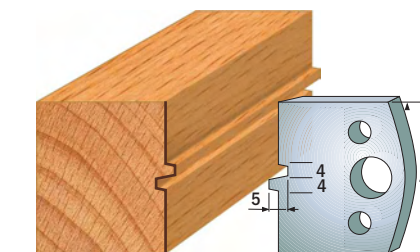

Pair of knives **690.074**

Note: all knives and limitors only available in pairs

Drawings are 1:2 scale Dimensions inmm.

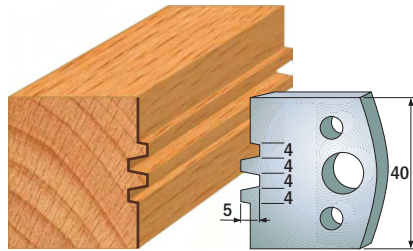

Pair of knives **690.075**

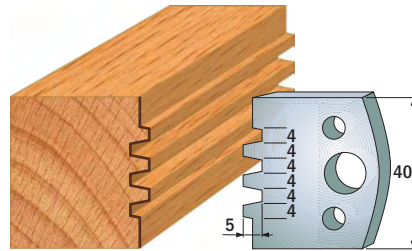

Pair of knives **690.076**

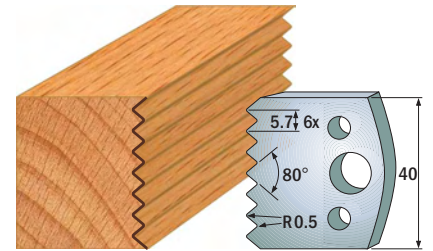

Pair of knives **690.077**

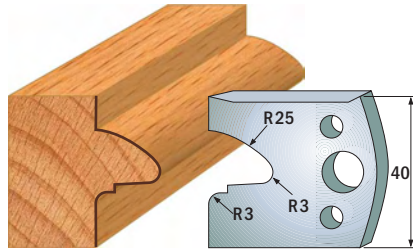

Pair of knives **690.078**

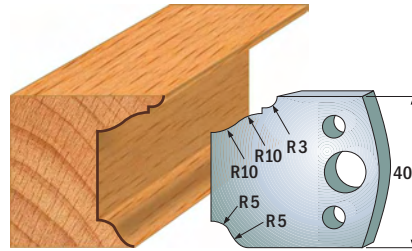

Pair of knives **690.079**

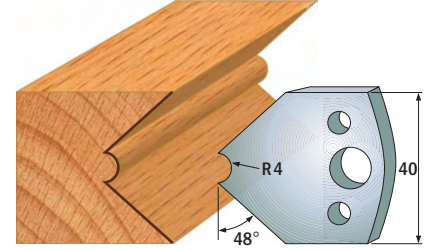

Pair of knives **690.080**

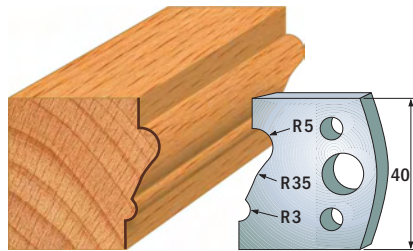

Pair of knives **690.081**

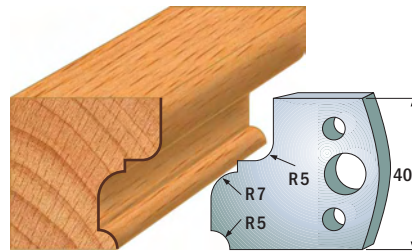

Pair of knives **690.082**

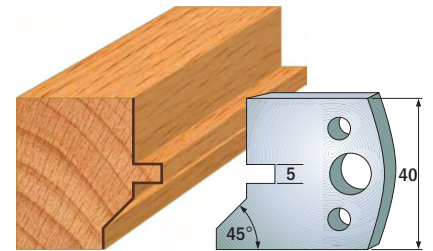

Pair of knives **690.083**

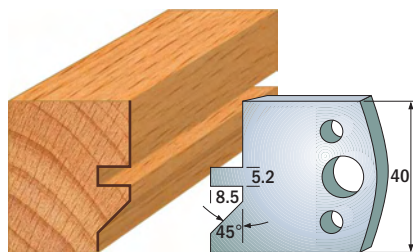

Pair of knives **690.084**

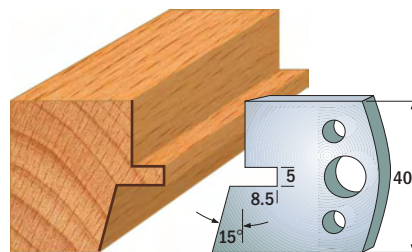

Pair of knives **690.085**

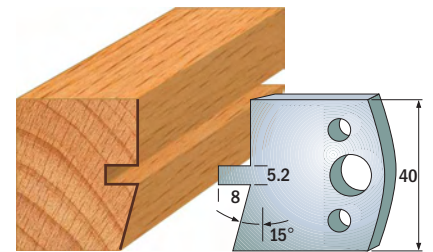

Pair of knives **690.086**

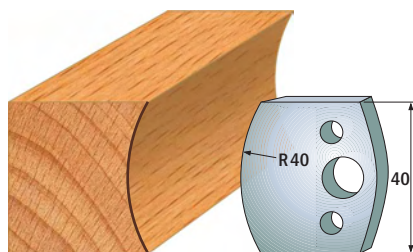

Pair of knives **690.087**

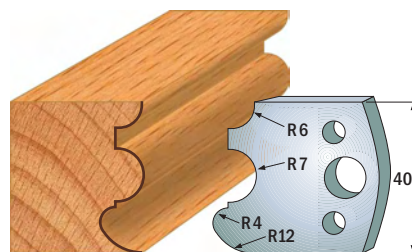

Pair of knives **690.088**

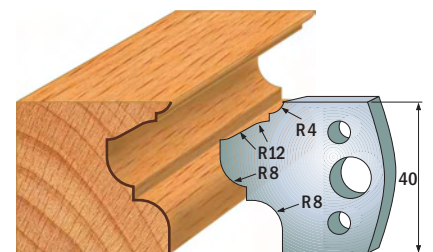

Pair of knives **690.089**

Note: all knives and limitors only available in pairs

Drawings are 1:2 scale Dimensions inmm.

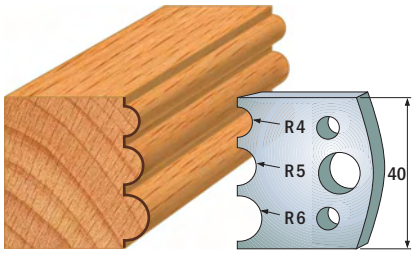

Pair of knives **690.090**

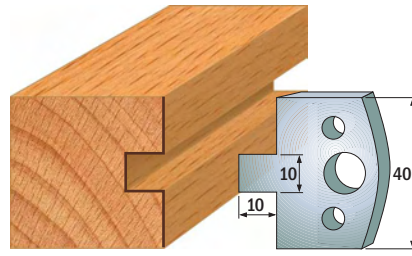

Pair of knives **690.091**

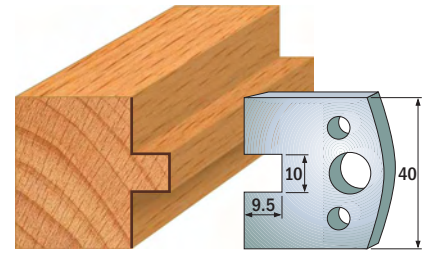

Pair of knives **690.092**

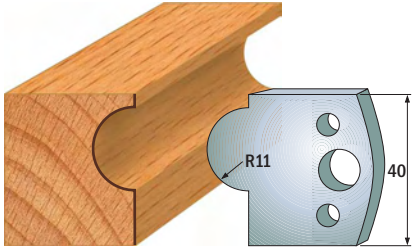

Pair of knives **690.093**

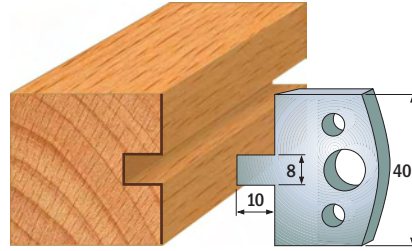

Pair of knives **690.094**

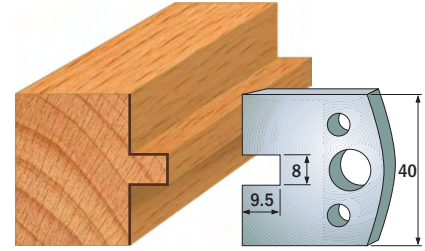

Pair of knives **690.095**

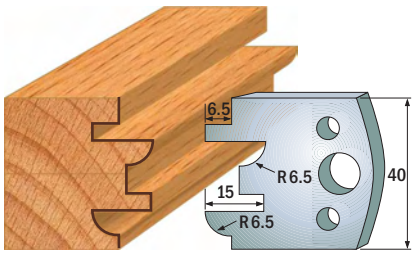

Pair of knives **690.096**

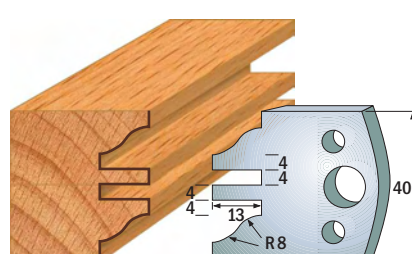

Pair of knives **690.097**

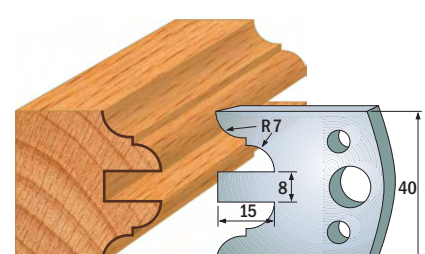

Pair of knives **690.098**

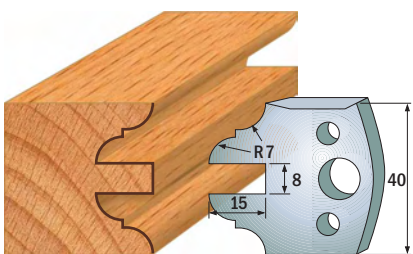

Pair of knives **690.099**

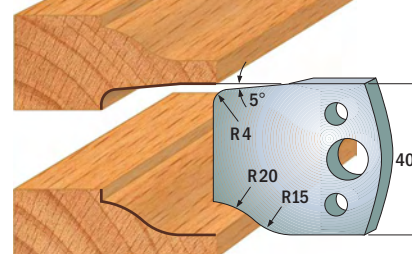

Pair of knives **690.100**

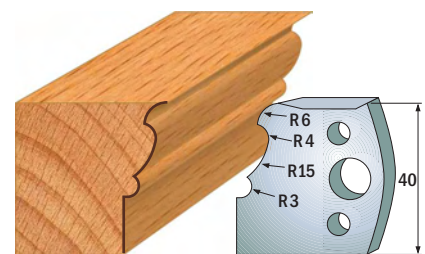

Pair of knives **690.101**

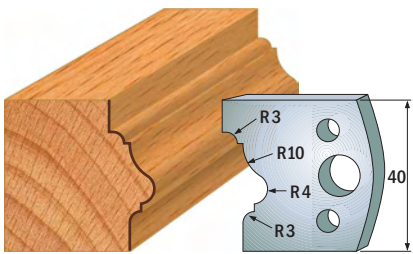

Pair of knives **690.102**

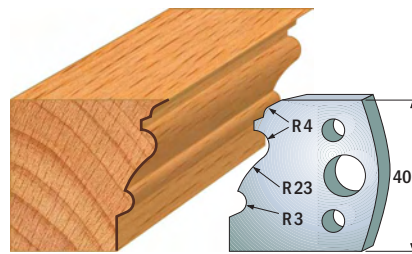

Pair of knives **690.103**

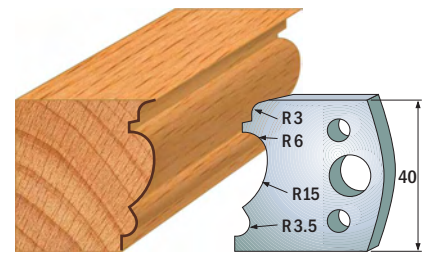

Pair of knives **690.104**

Note: all knives and limitors only available in pairs

Drawings are 1:2 scale Dimensions inmm.

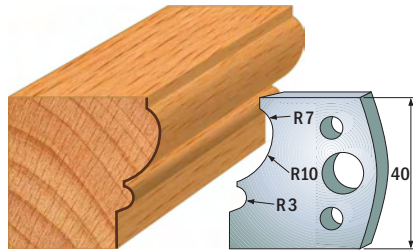

Pair of knives **690.105**

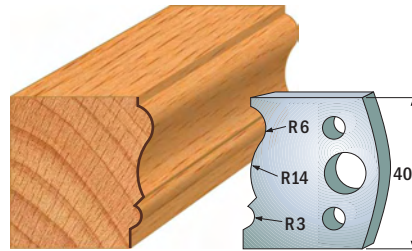

Pair of knives **690.106**

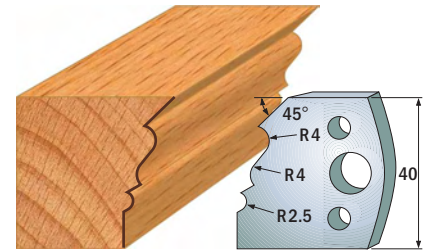

Pair of knives **690.107**

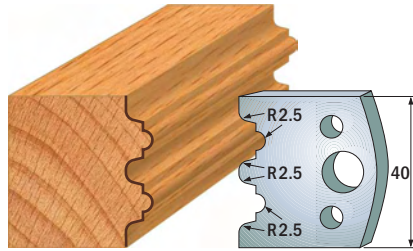

Pair of knives **690.108**

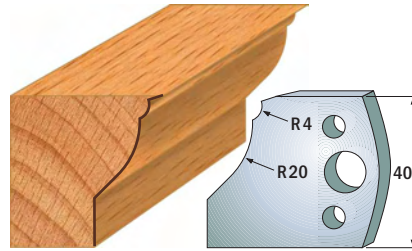

Pair of knives **690.109**

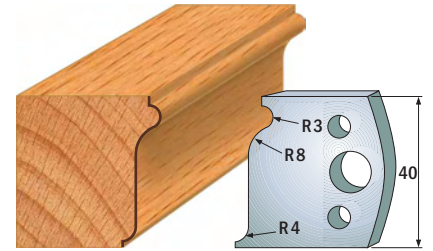

Pair of knives **690.110**

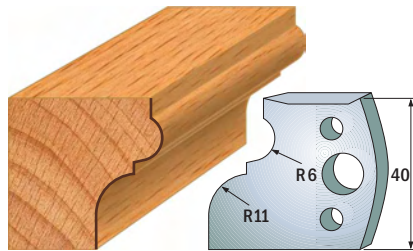

Pair of knives **690.111**

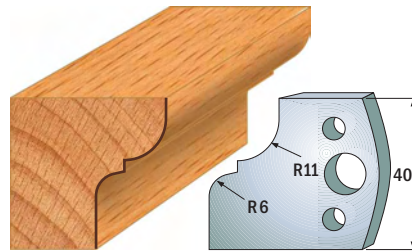

Pair of knives **690.112**

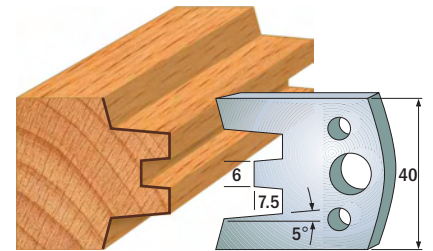

Pair of knives **690.113**

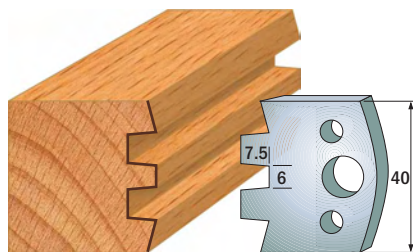

Pair of knives **690.114**

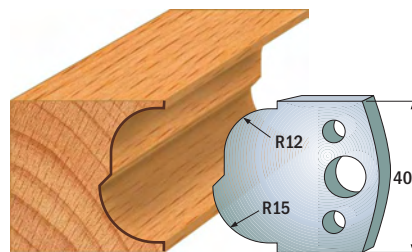

Pair of knives **690.115**

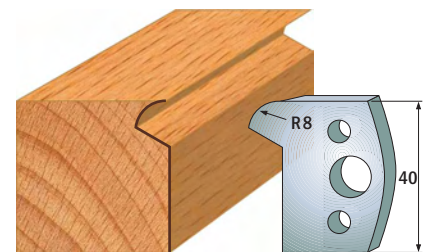

Pair of knives **690.116**

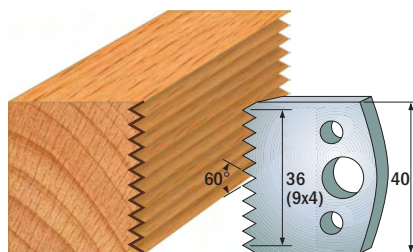

Pair of knives **690.117**

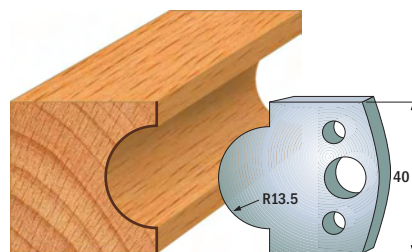

Pair of knives **690.118**

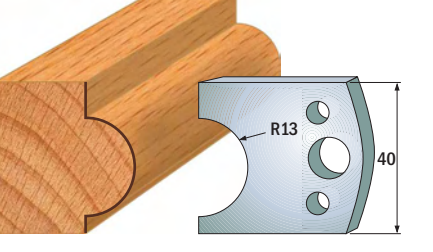

Pair of knives **690.119**

Note: all knives and limitors only available in pairs

Drawings are 1:2 scale Dimensions inmm.

Profile Knives for the Insert Shaper System

$l = 1\text{-}37/64''$ (40mm) - $T = 5/32''$ (4mm)

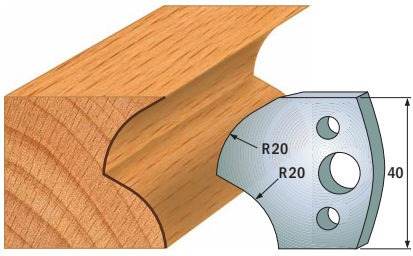

Pair of knives **690.120**

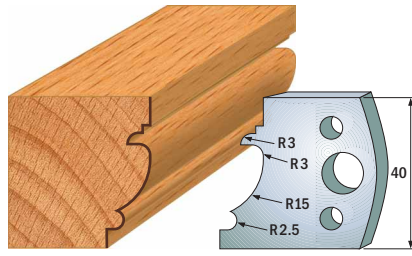

Pair of knives **690.121**

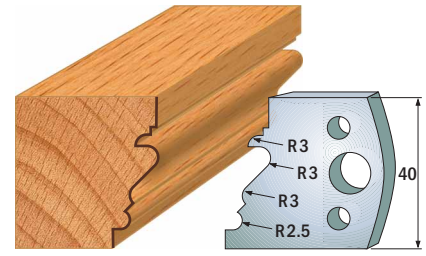

Pair of knives **690.122**

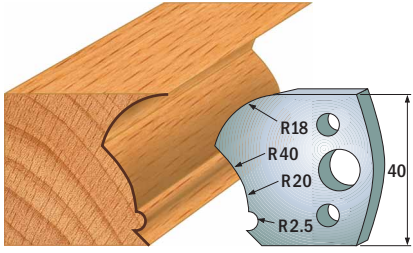

Pair of knives **690.123**

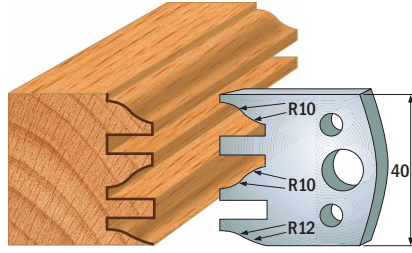

Pair of knives **690.124**

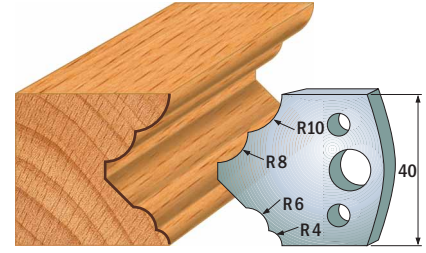

Pair of knives **690.125**

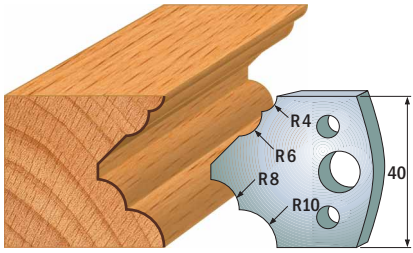

Pair of knives **690.126**

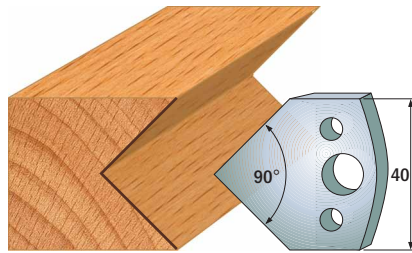

Pair of knives **690.127**

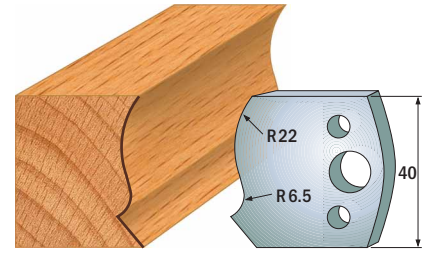

Pair of knives **690.128**

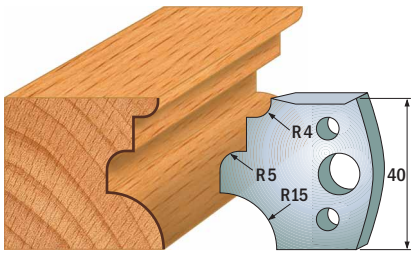

Pair of knives **690.129**

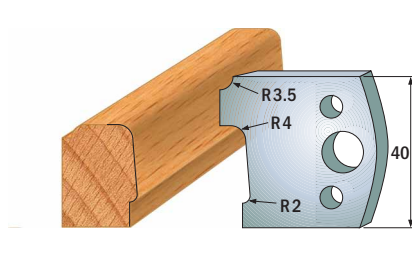

Pair of knives **690.130**

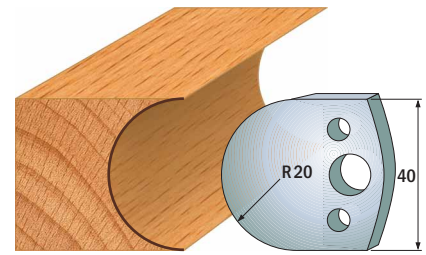

Pair of knives **690.131**

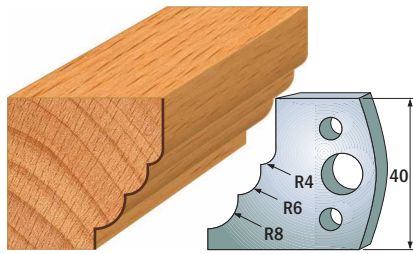

Pair of knives **690.132**

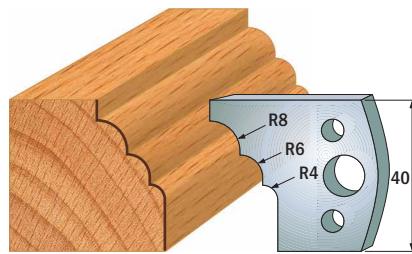

Pair of knives **690.133**

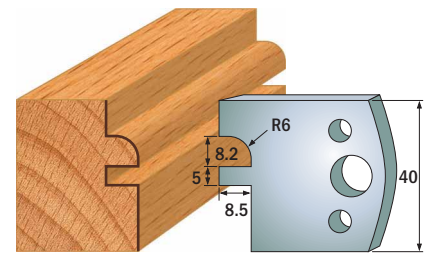

Pair of knives **690.134**

l = Cutting leght

Note: all knives and limitors only available in pairs

T = Thickness

Drawings are 1:2 scale Dimensions inmm.

I= 1-37/64" (40mm) - T= 5/32" (4mm)

Profile Knives for the Insert Shaper System

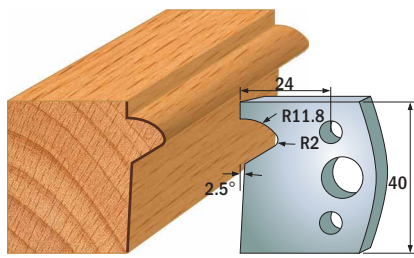

Pair of knives **690.135**

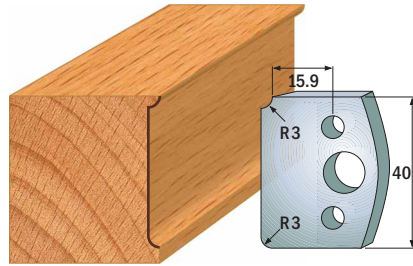

Pair of knives **690.170**

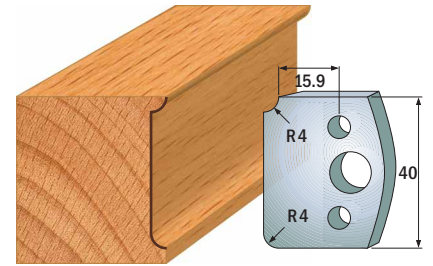

Pair of knives **690.171**

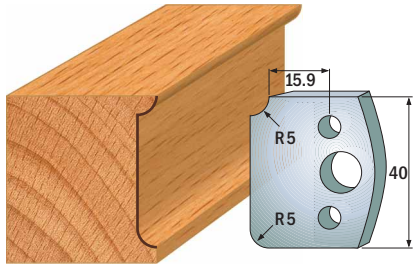

Pair of knives **690.172**

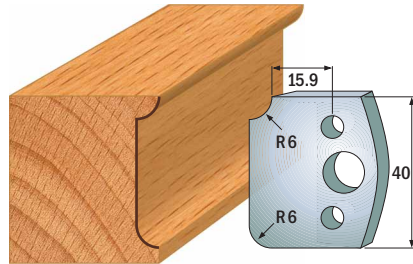

Pair of knives **690.173**

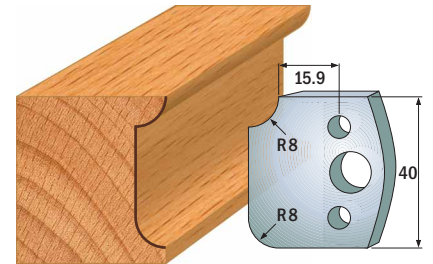

Pair of knives **690.174**

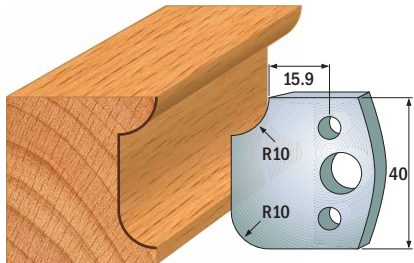

Pair of knives **690.175**

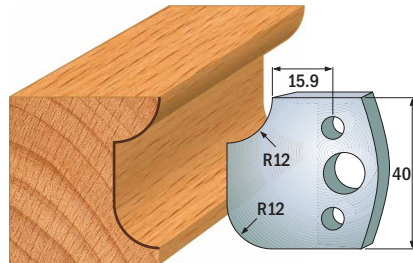

Pair of knives **690.176**

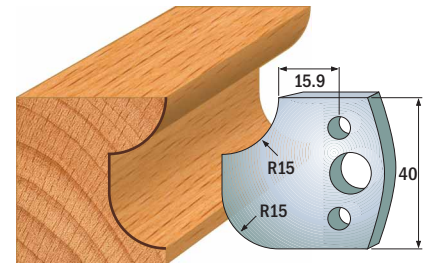

Pair of knives **690.177**

Profile Knives for the Insert Shaper System

I= 1-31/32" (50mm) - T= 5/32" (4mm)

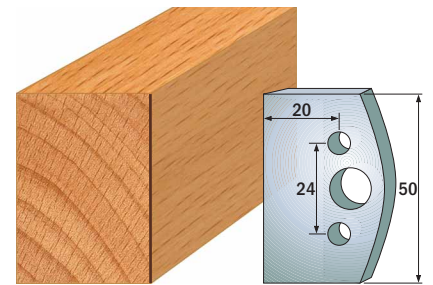

Pair of knives **690.500**

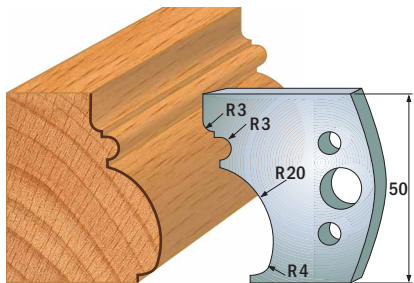

Pair of knives **690.501**

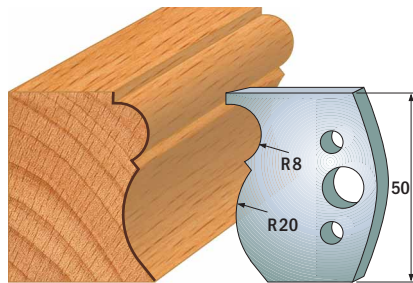

Pair of knives **690.502**

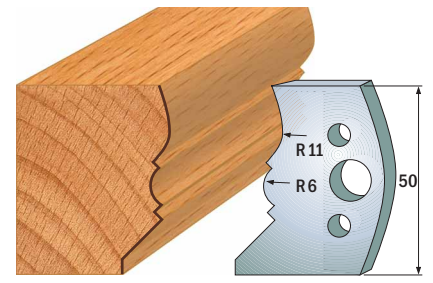

Pair of knives **690.503**

I= Cutting length

T= Thickness

Note: all knives and limitors only available in pairs

Drawings are 1:2 scale Dimensions inmm.

Profile Knives for the Insert Shaper System

50mm high

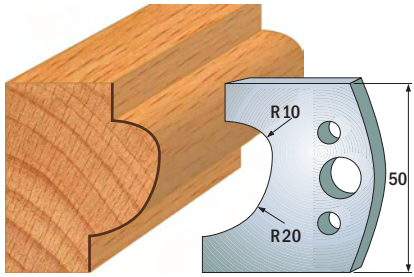

Pair of knives **690.504**

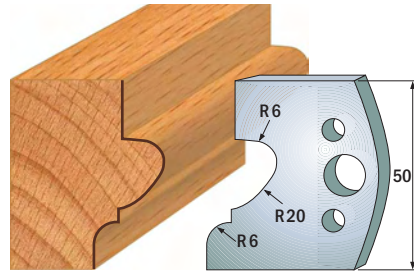

Pair of knives **690.505**

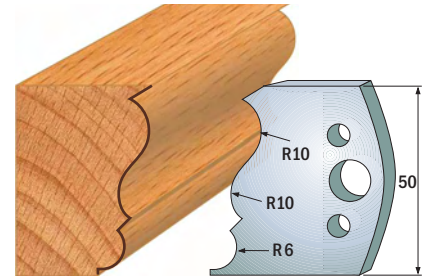

Pair of knives **690.506**

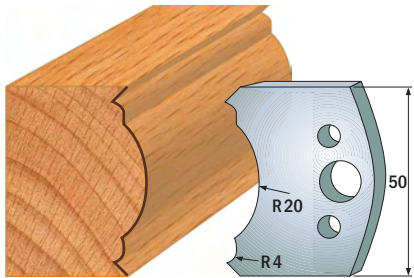

Pair of knives **690.507**

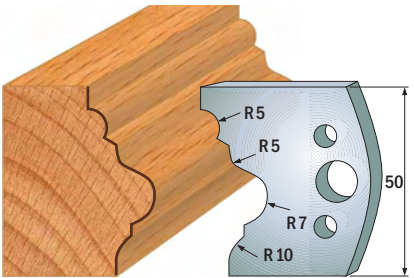

Pair of knives **690.508**

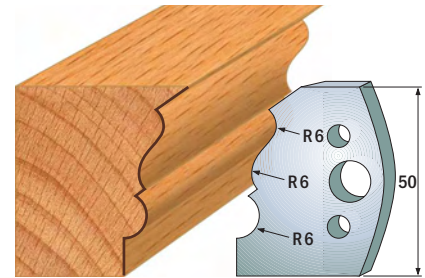

Pair of knives **690.509**

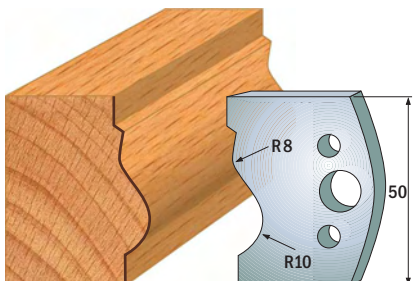

Pair of knives **690.510**

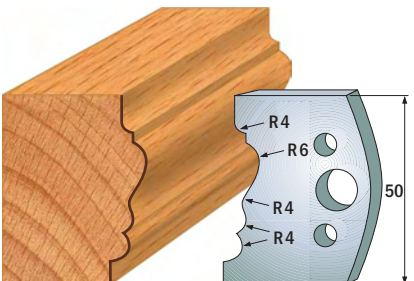

Pair of knives **690.511**

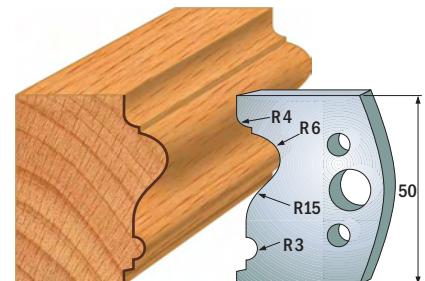

Pair of knives **690.512**

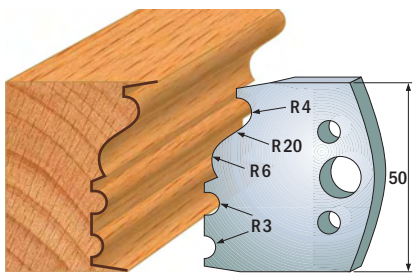

Pair of knives **690.513**

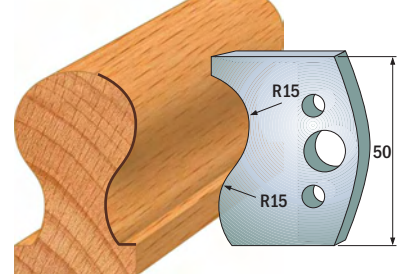

Pair of knives **690.514**

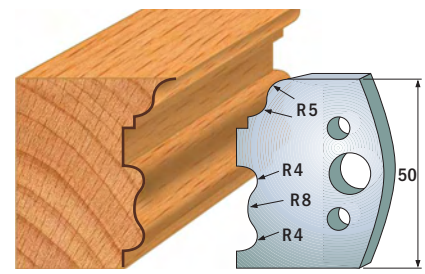

Pair of knives **690.515**

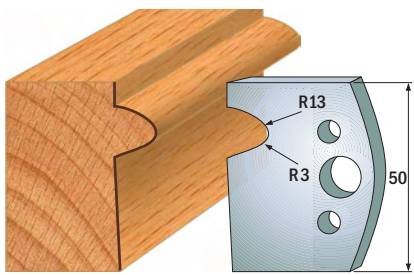

Pair of knives **690.516**

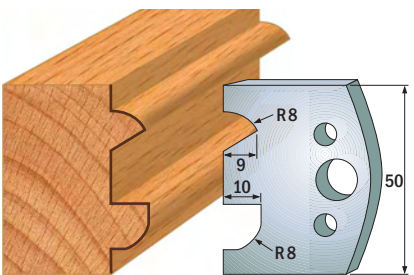

Pair of knives **690.517**

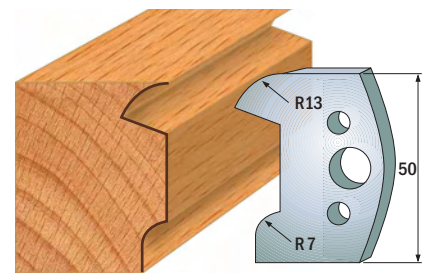

Pair of knives **690.518**

Note: all knives and limitors only available in pairs

Drawings are 1:2 scale Dimensions inmm.

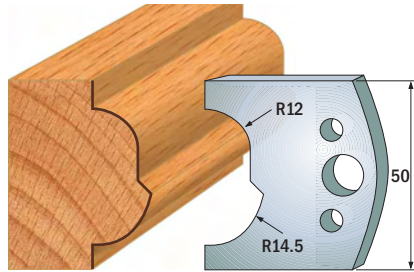

Pair of knives **690.519**

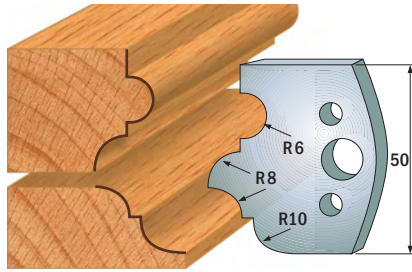

Pair of knives **690.520**

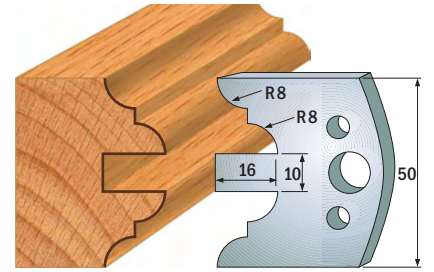

Pair of knives **690.522**

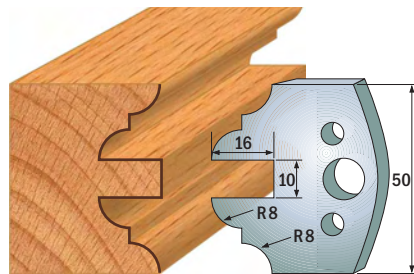

Pair of knives **690.523**

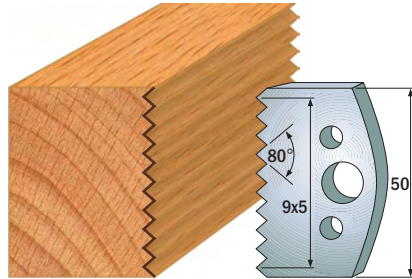

Pair of knives **690.524**

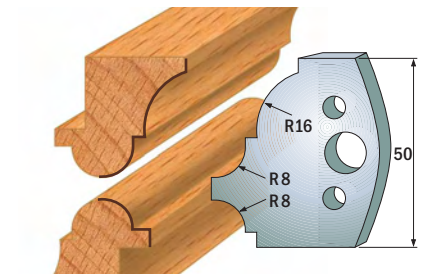

Pair of knives **690.541**

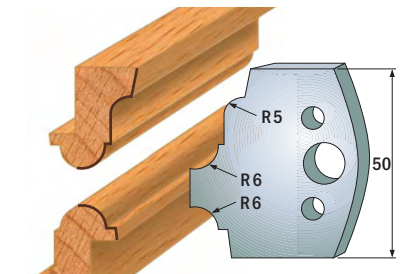

Pair of knives **690.542**

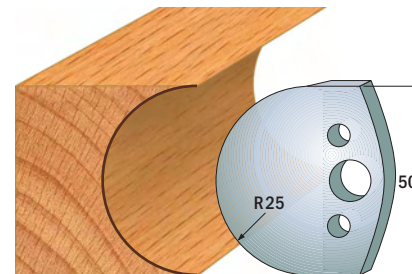

Pair of knives **690.543**

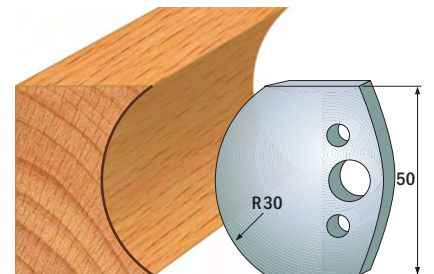

Pair of knives **690.544**

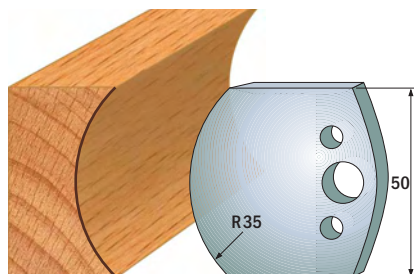

Pair of knives **690.545**

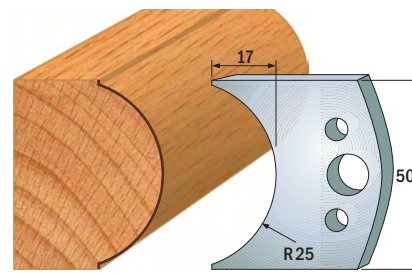

Pair of knives **690.546**

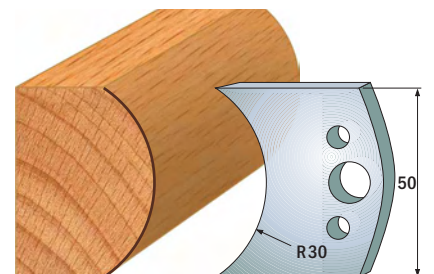

Pair of knives **690.547**

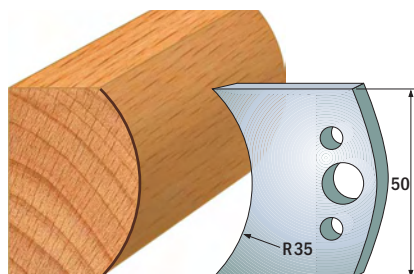

Pair of knives **690.548**

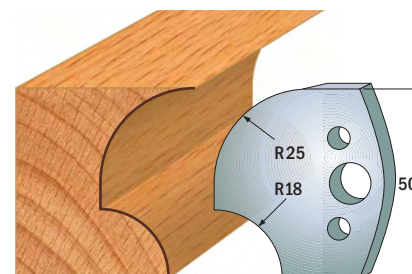

Pair of knives **690.549**

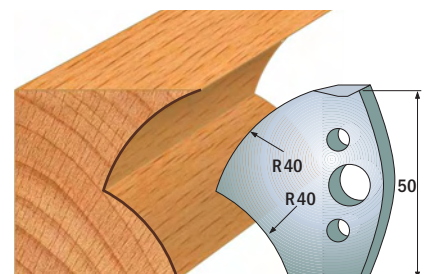

Pair of knives **690.550**

Note: all knives and limitors only available in pairs

Drawings are 1:2 scale Dimensions inmm.

Profile Knives for the Insert Shaper System

50mm high

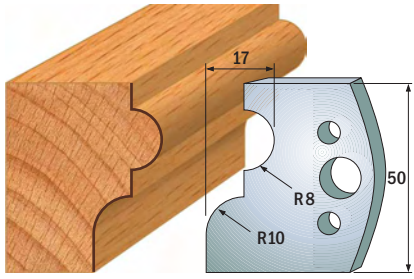

Pair of knives

690.551

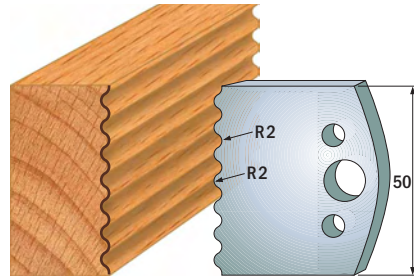

Pair of knives

690.552

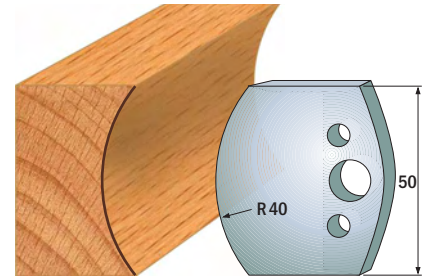

Pair of knives

690.553

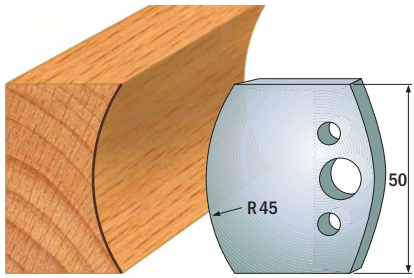

Pair of knives

690.554

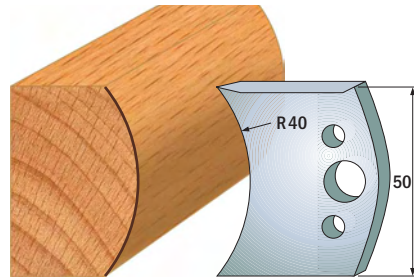

Pair of knives

690.555

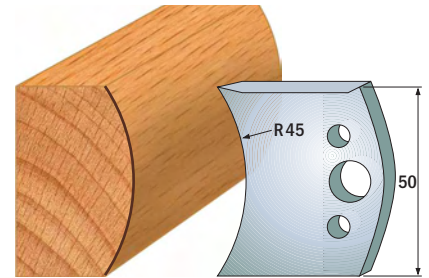

Pair of knives

690.556

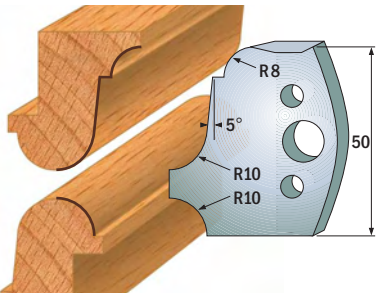

Pair of knives

690.557

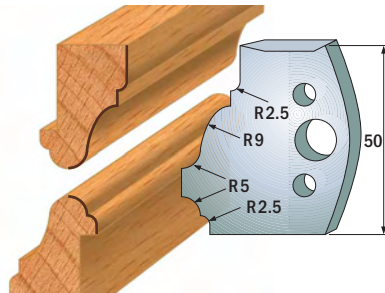

Pair of knives

690.558

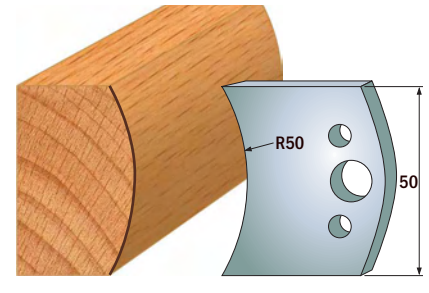

Pair of knives

690.559

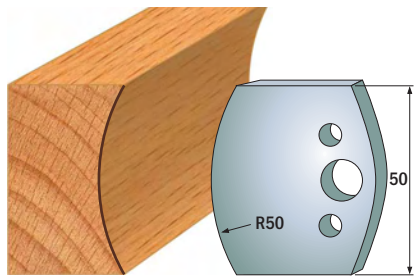

Pair of knives

690.560

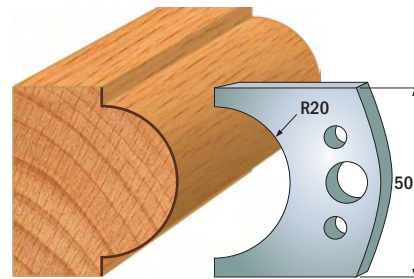

Pair of knives

690.561

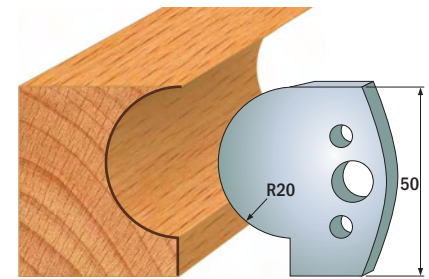

Pair of knives

690.562

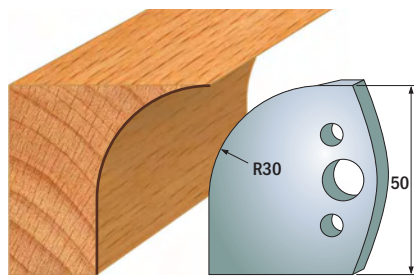

Pair of knives

690.563

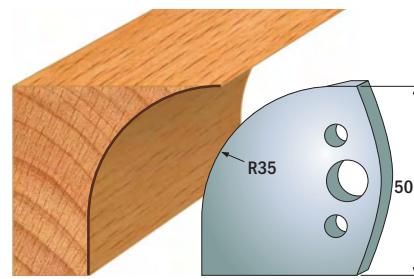

Pair of knives

690.564

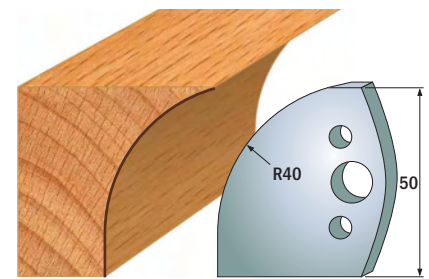

Pair of knives

690.565

Note: all knives and limitors only available in pairs

Drawings are 1:2 scale Dimensions inmm.

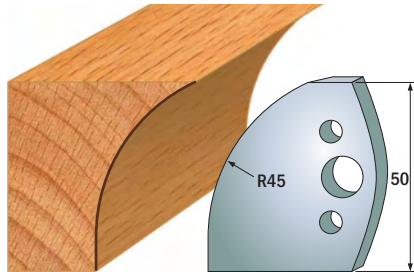

Pair of knives **690.566**

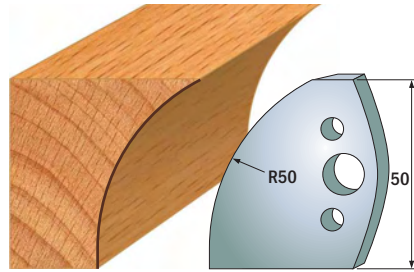

Pair of knives **690.567**

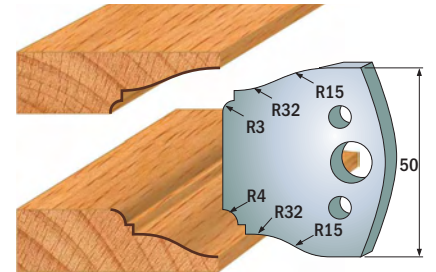

Pair of knives **690.568**

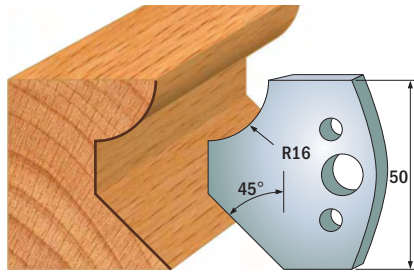

Pair of knives **690.569**

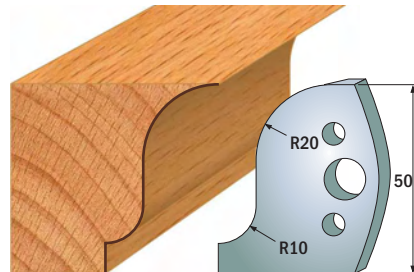

Pair of knives **690.570**

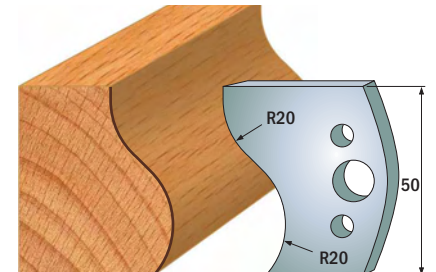

Pair of knives **690.571**

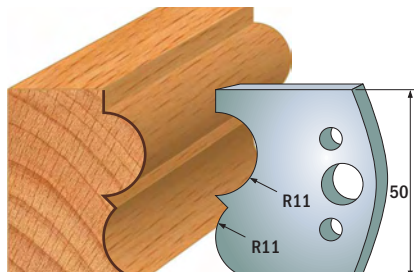

Pair of knives **690.572**

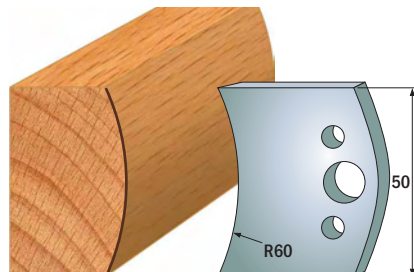

Pair of knives **690.573**

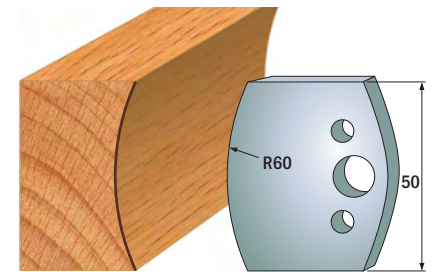

Pair of knives **690.574**

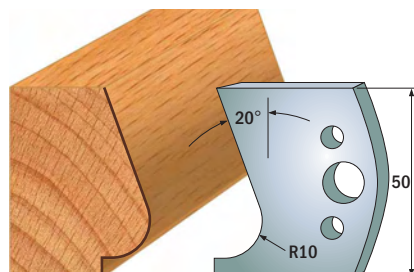

Pair of knives **690.575**

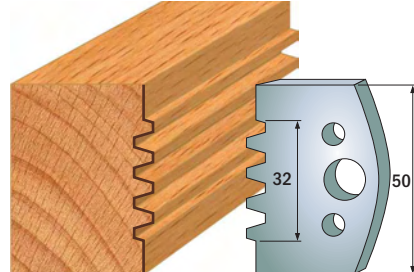

Pair of knives **690.576**

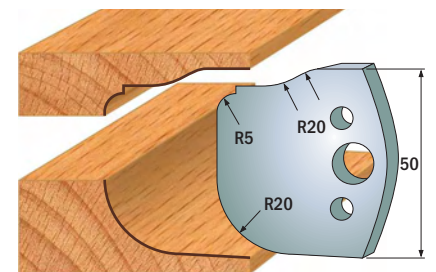

Pair of knives **690.577**

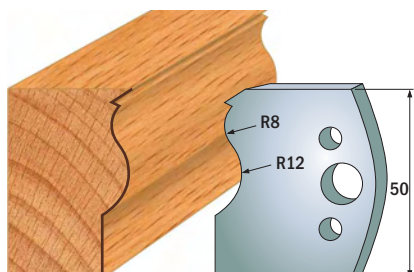

Pair of knives **690.578**

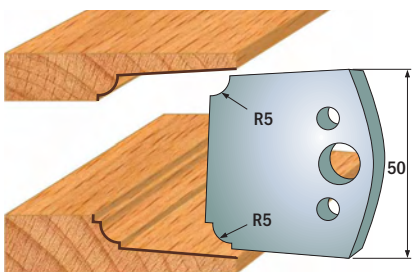

Pair of knives **690.579**

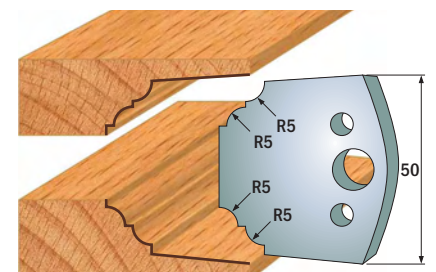

Pair of knives **690.580**

Note: all knives and limitors only available in pairs

Drawings are 1:2 scale Dimensions inmm.

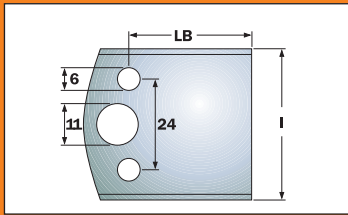

Order No.	Description	LB_Adjusting length mm	I_Cutting length mm
690.193	Blank knives	32.5	40
690.599	Blank knives	34	50

Planer and Jointer Knives HS 18%W

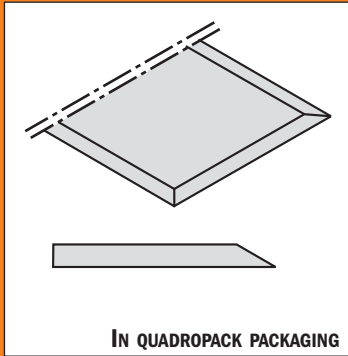

792

Order No.	Length mm	Width mm	Thickness mm	Knives per set
792.130.30	130	30	3	2
792.150.30	150	30	3	2
792.180.30	180	30	3	2
792.230.30	230	30	3	2
792.400.30	400	30	3	2
792.400.35	400	35	3	2
792.500.35	500	35	3	2
792.600.35	600	35	3	2
792.710.35	710	35	3	2
792.997.30	1050	30	3	2
792.997.35	1050	35	3	2

APPLICATION:

Soft wood, dry.....Excellent
 Hard wood, wet.....Excellent
 Soft wood, wetGood

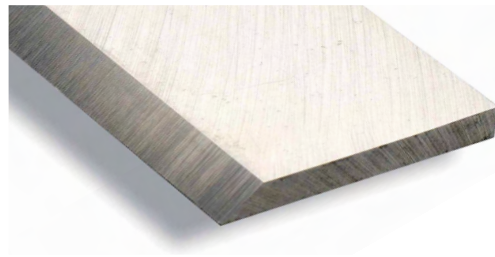

Magnetic Knife Setting Jigs

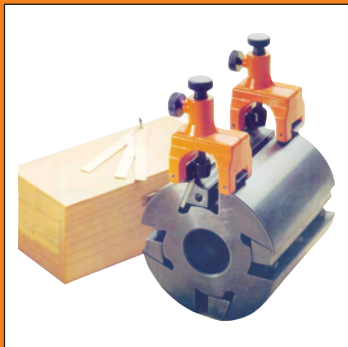

CMT792

The best knives won't perform well unless they are properly installed and aligned. The built-in magnets grip both the planer head and the knives while you use the integral adjustments to get the knives in perfect position.

- 1. MAGNETIZED CERAMIC STOP**
- 2. JOINTS WITH MAGNETIZED CONNECTORS**
- 3. PRECISION DEPTH STOP**

Set supplied in a wooden box with 2 setters and gauges thickness 0,8 - 1 - 1,2mm.

3 possibilities of setting up

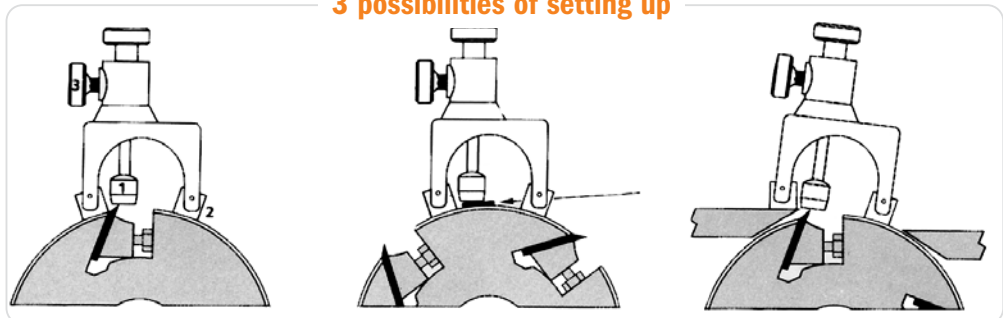

Positioning onto the toolholder body with marking onto the original knife.

Positioning onto the toolholder body setting with on of the supplied gauges.

Positioning directly onto the machine table and the toolholder body.

794

Order No.	Knife length inches	Knife width inches	Knife thickness inches	Knives per set
794.101	4	5/8	1/8	3
794.151	6	5/8	1/8	3
794.152	6	3/4	1/8	3
794.153	6	7/8	1/8	3
794.154	6	1	1/8	2
794.155	6-1/16	13/16	1/8	3
794.161	6-1/8	5/8	3/32	3
794.202	8	5/8	1/8	3
794.203	8	3/4	1/8	3
794.204	8	7/8	1/8	3
794.205	8	1	1/8	3
794.206	8-1/16	5/8	3/32	3
794.207	8-1/16	13/16	1/8	3
794.301	12	5/8	1/8	3
794.302	12	3/4	1/8	3
794.303	12	7/8	1/8	3
794.304	12	1	1/8	3
794.305	12	1-1/4	1/8	3
794.311	12-1/4	3/4	1/8	3
794.312	12-1/4	1	1/8	3
794.321	12-1/2	11/16	1/8	3
794.331	13-1/8	11/16	5/32	1
794.332	13-1/8	1	1/8	3
794.381	15	1	1/8	3
794.461	18	1-1/8	5/32	1
794.511	20	1	1/8	1
794.512	20	1-3/16	1/8	4
794.521	20-1/2	11/16	1/8	3
794.611	24	1-1/4	1/8	1
794.641	25	5/8	3/32	1
794.642	25	5/8	1/8	1
794.643	25	3/4	1/8	1
794.644	25	7/8	1/8	1
794.645	25	1	1/8	1
794.646	25	1-1/4	1/8	1
794.647	25	1-1/4	5/32	1
794.648	25	35mm	1/8	1
794.941	37	1-1/8	1/8	1
794.942	37	1-1/4	5/32	1
794.943	37	1-3/8	5/32	1
794.944	37	1-1/2	5/32	1



APPLICATION:

Soft wood, dry.....Excellent
 Hard wood, wet.....Excellent
 Soft wood, wetGood

CMT's new selection of Planer & Jointer Knives are carefully ground from fine European high speed steel. You'll appreciate the high quality finish on these tools, and more important, you'll love the excellent finish they produce on your work!

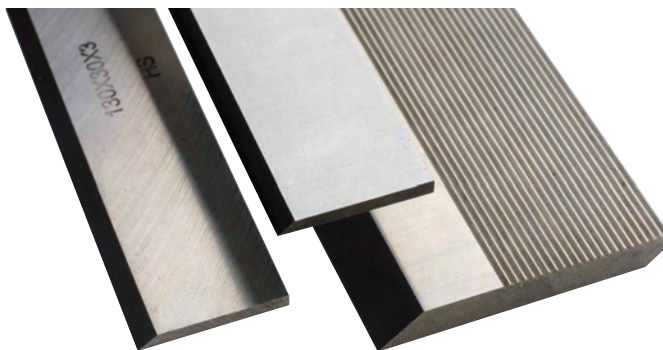

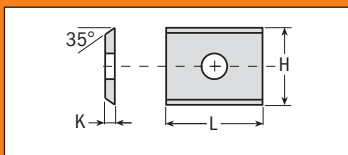

Standard reversible knives 2 cutting edges 35°

790

Dimensions mm			ORDER No.			
L	H	K	HC05	MG06	SMG02	UMG04
7,5	12	1,5	790.075.00			
9,6	12	1,5	790.096.00			
15	12	1,5	790.150.00			
20	12	1,5	790.200.00	790.200.02	790.200.03	

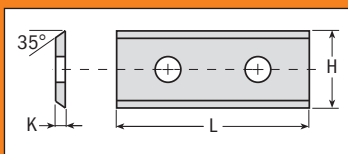

Standard reversible knives 2 cutting edges 35°

790

Dimensions mm			ORDER No.			
L	H	K	HC05	MG06	SMG02	UMG04
25	12	1,5	Y790.250.00			
30	12	1,5	790.300.00	790.300.02	790.300.03	S790.300.04
40	12	1,5	790.400.00	790.400.02	790.400.03	
50	12	1,5	790.500.00	790.500.02	790.500.03	S790.500.04
60	12	1,5	790.600.00		S790.600.03	

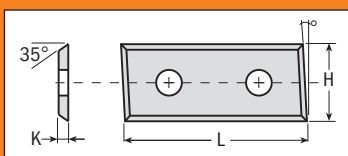

Standard reversible knives 4 cutting edges 35°

790

Dimensions mm			ORDER No.			
L	H	K	HC05	MG06	SMG02	UMG04
28,3	12	1,5	790.283.12			
48,3	12	1,5	790.483.12			

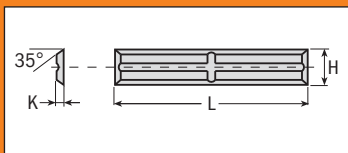

Standard reversible knives 4 cutting edges 35°

790

Dimensions mm			ORDER No.			
L	H	K	HC05	MG06	SMG02	UMG04
20	4,1	1,1	790.200.01			
30	5,5	1,1	790.300.01			

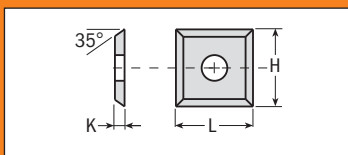

Standard reversible knives 4 cutting edges 35°

790

Dimensions mm			ORDER No.			
L	H	K	HC05	MG06	SMG02	UMG04
12	12	1,5 (35°)	790.120.00	790.120.02	790.120.03	
14	14	1,2 (30°)	790.140.10			
14	14	2 (30°)	790.140.00		790.140.03	
14	14	2 (45°)		790.140.02		

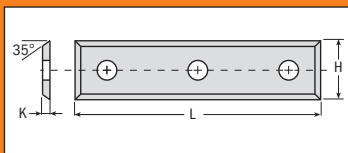

Standard reversible knives 4 cutting edges 35°

790

Dimensions mm			ORDER No.			
L	H	K	HC05	MG06	SMG02	UMG04
50	9	1,5	790.500.09			

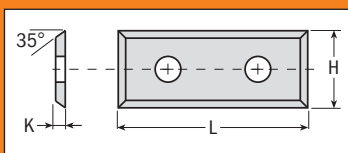

Standard reversible knives 4 cutting edges 35°

790

Dimensions mm			ORDER No.			
L	H	K	HC05	MG06	SMG02	UMG04
29,5	9	1,5	790.295.09			
29,5	12	1,5	790.295.12			
49,5	9	1,5	790.495.09			
49,5	12	1,5	790.495.12			

Special reversible knives 2 cutting edges 35°

790

Dimensions mm			ORDER No.			
L	H	K	HC05	MG06	SMG02	UMG04
20 x 12	1,5		790.201.00			
30 x 12	1,5		790.301.00			
50 x 12	1,5		790.501.00			

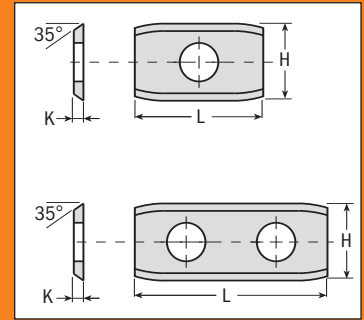

Standard reversible knives 4 cutting edges 35°

790

Dimensions mm			ORDER No.			
L	H	K	HC05	MG06	SMG02	UMG04
18 x 18	2		790.181.00			
18 x 18	2,5		790.182.00			

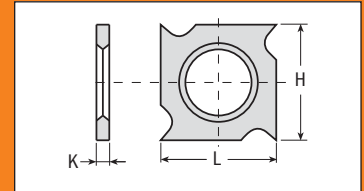

Standard reversible knives 35°

790

Dimensions mm			ORDER No.			
L	H	K	HC05	MG06	SMG02	UMG04
22 x 19	2		790.220.02			

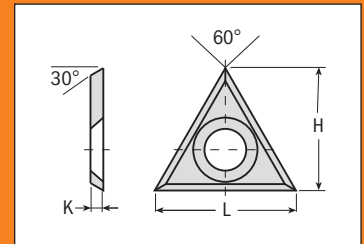

Edge rounding reversible knives 35°

790

Dimensions mm			ORDER No.			
L	H	K	HC05	MG06	SMG02	UMG04
R 1,5	16 x 22	5	790.161.00			
R 2	16 x 22	5	790.162.00			
R 3	16 x 22	5	790.163.00			
45°	16 x 22	5	790.160.00			

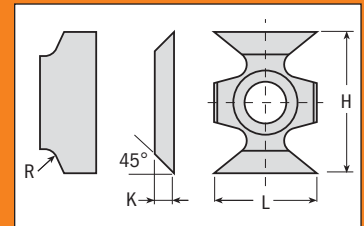

Profiled rounding reversible knives 4 cutting edges 35°

790

Dimensions mm			ORDER No.			
L	H	K	HC05	MG06	SMG02	UMG04
R 2	19,5 x 9	1,5	790.020.00			
R 3	19,5 x 9	1,5	790.030.00			
R 5	19,5 x 9	1,5	790.050.00			
R 6,4	24 x 12	1,5	790.064.00			
R 8	24 x 12	1,5	790.080.00			

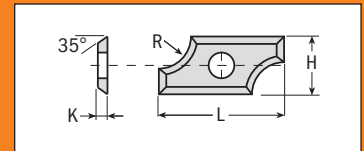

All knives supplied in 10 pcs. case.

TECHNICAL DETAILS FOR CARBIDE GRADES:

- HC** Hardness (HRA): 92.7 - Transverse rupture strength (P.S.I.): 305,000
- MG** Hardness (HRA): 92.3 - Transverse rupture strength (P.S.I.): 536,500
- SMG** Hardness (HRA): 95.2 - Transverse rupture strength (P.S.I.): 508,000
- UMG** Hardness (HV10): 2.550 - Transverse rupture strength (P.S.I.): 464,000

MATERIAL	HC	MG	SMG	UMG
Dry Softwood	●			
Wet Softwood	●			
Dry Hardwood	●	●		
Wet Hardwood	●	●		
Chipboard		●	●	●
MDF		●	●	●
HDF			●	●
Solid Surface				●

● Excellent

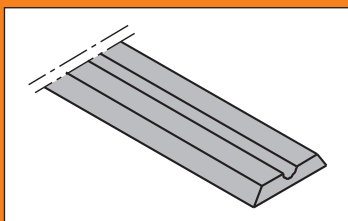

10-PCS. CASE

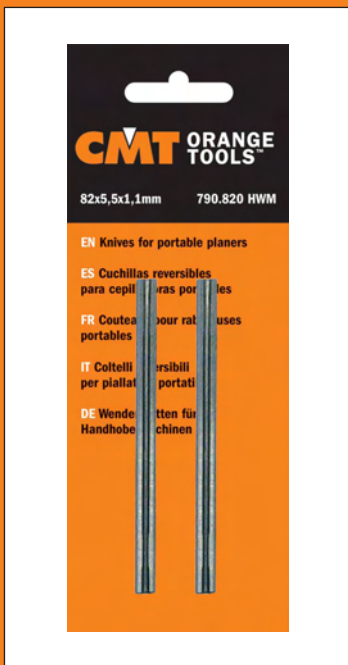

*2-PCS. BLISTER CASE



10-PCS. CASE

790

Order No.	Knives dimensions mm	Brand	Model
790.560.00	56.0 x 5.5 x 1.1	Adler	
790.600.01	60.0 x 5.5 x 1.1	Wegoma	
790.755.00	75.5 x 5.5 x 1.1	Aeg	HTH75
		Black & Decker	DN75, 750SR, 600K
		Bosch	0590, P400, 1590, 1591
		Festo	REP75
		Haffner	FH222
		Holz-Her	2223, 2286, 2320
		Kress	Jet-Star 6701, 6702
		Mafell	HU75
		Metabo	6375
		Scheer	MH75/3, MH80
		Skil	98H
790.805.00	80.5 x 5.9 x 1.2	Elu	MFF40, MFF80, MFF81, MFF81EK, PF161
790.805*	80.5 x 5.5 x 1.1	Elu	MFF80
		Aeg	
		Bosch	
		Haffner	
790.820*	82.0 x 5.5 x 1.1	Aeg	EH82, EH825, EH822, EH450, EH700, EH82-1, H500, H750, EH700R
		Black & Decker	DN76
		Bosch	PHO 100/150, PHO 200/300 4387, PHO 2-82/3-82, Gustav H00882
		Casals	CE82
		DeWalt	DW678, DW678EK, DW680
		Elu	HH15, HH40, HH40K, HH40EK
		Fein	HS2151
		Felisatti	TP282
		Haffner	FH224
		Hitachi	F20, F20A, FP20A, P20V, P20SA
		Holz-Her	2321, 2322
		Legna	R82, G82
		Mafell	EHU82, MHU82
		Makita	1001, 1100, 1125B, 1900B, 1901, 1923B, 1923H, 1923HO
		Metabo	4382, 8382, 0882, 0883, E0983
		Perless	HHB82B
		Peugeot	RA400, 82RAC, RA82CS, BR82 BRA1-82, BRA3-82, RA1082CA
		Ryobi	L1323-A
		Skil	H92, H94, H95, H96, H97 1506, 1510 980B
		Stayer	980B
790.827.00	82.7 x 5.5 x 1.1	Black & Decker	DN710, DN712, DN730, DN71-02, DN71-03, BD711
790.920.00	92.0 x 5.5 x 1.1	Aeg	450
		Hitachi	F30A, FU30
		Ryobi	L120N, L150N, L1205N, L1323
790.992.00	102.0 x 5.5 x 1.1	Aeg	HB750, EH102, HBE800

TECHNICAL DETAILS:

- Code USAC1
- Hardness (HRA)90.3
- Transverse rupture strength (P.S.I.):377,000

APPLICATION:

- Soft wood Good
- Hard wood Average
- Plywood Average

Saw Blades



...Diamond Blade for Fiber Cements 144



...ITK Framing/Decking Blades 145



...Ultra-ITK for Cordless Saws 149



...Precision Dado Set 151



...Ripping Blades 153



...General Blades 156



...Cabinet Shop Blade 158



...Dry Cut Blade 159



...Biscuit Joiner Blade 165

Three great blade families, and more:

New Industrial Blades

ITK™ Industrial Thin Kerf Blades

PTFE-Coated Blades



Plus: Dado Sets, Biscuit Joiner Blades,

DP, Non-Ferrous, Dry Cut, Solid Surface & Plexiglass Saw Blades

No matter which CMT blade you buy, you can rest easy knowing you are receiving the finest European quality, a superior warranty and a host of key features, including:

- teeth ground from the finest micrograin carbide
- premium laser-cut steel plate
- the latest in blade design technology and manufacturing.

Of course, we offer multiple lines of blades for a good reason: to provide woodworkers with precisely the right blade for their application.

The following pages contain complete descriptions and specifications for each blade, but here is some general information to keep in mind as you make your selection:

Industrial Blades:

Intended primarily for large panel saws and other industrial woodworking machinery. Note: these blades are listed with metric dimensions to match your machine specs.

ITK™ Industrial Thin Kerf Blades:

Thinner plates make the ITK line ideal for saws that are a bit underpowered, but they also deliver a hard day's work, and these prices make them an incredible value.

PTFE-Coated Blades:

A great choice for the shop that keeps its blades running all day, every day. With their heavy-gauge plate, these blades have the stamina for saws with lots of power.

Diamond Saw Blade for Fiber Cement Products

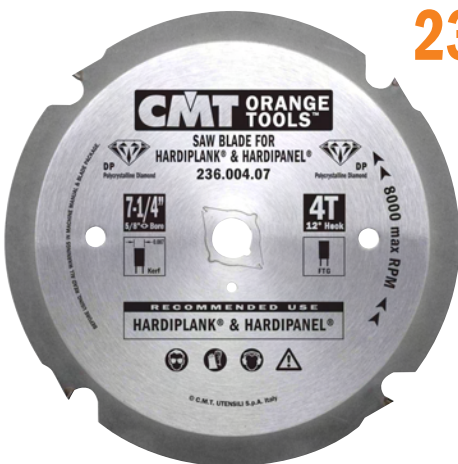

236 DP

CMT's diamond blades are your best choice for Hardi® products and other brands of fiber cement board. These tools are top quality European blades, featuring four polycrystalline diamond teeth for great cuts in Hardiplank® and Hardipanel®. Blades are 5/8" arbor with a diamond knockout and 1" arbor. CMT's unique molded blade case included.

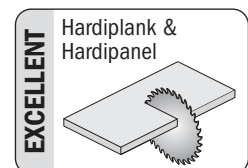

Order No. 1 pc.	Diameter inches mm	No. of teeth	Bore inches	Kerf inches	Plate inches
236.004.07	7-1/4 184	4	5/8 <>	0.087	0.063
236.006.10	10 254	6	5/8	0.087	0.063
236.008.12	12 305	8	1	0.087	0.063

Take the finest industrial quality blade right to the job site with CMT's new Framing/Decking blade. With 24 tough carbide teeth, these blades are designed for general rip and cut off work where speed, efficiency and durability are the key considerations. Now featuring hollow ground teeth.

CARBIDE TIPPED    **250**

CARBIDE GRADE	HARDNESS	HRA	91.5
	RUPTURE STRENGTH	PS.I.	377,000

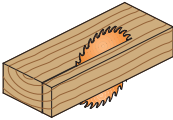
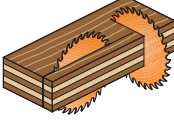
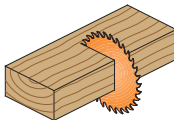
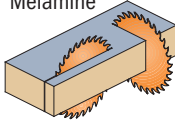
EXCELLENT Rip wood  Plywood  Crosscut wood  **GOOD** 2-sided Melamine 

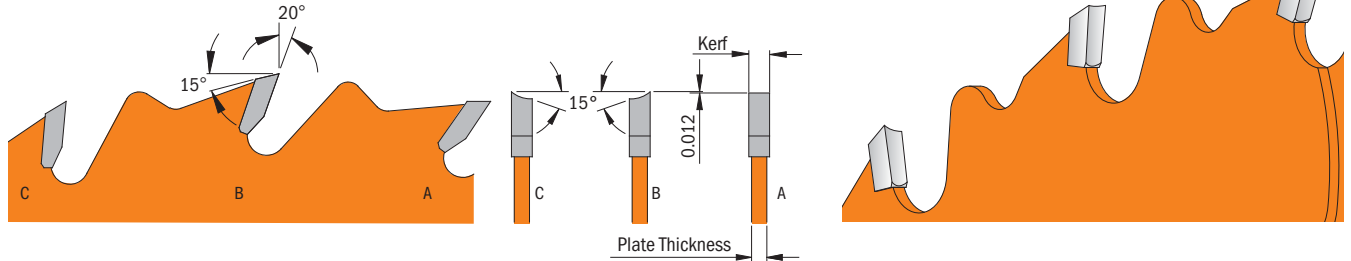

Order No.		Diameter		No. of teeth	Bore inches	Type of grind	Kerf inches	Plate inches	Hook Angle
1 pc.	Masterpack 10 pcs.	inches	mm						
250.024.07	250.024.07-X10	7-1/4	184	24	5/8 <>	15° HDF	0.071	0.047	20°

ITK Finish Blades

CMT's ITK Fine Finish blades let you produce excellent finish cuts anywhere you can carry your portable saw: in the shop, on the job site, or wherever the highest quality cuts are critical.

CARBIDE TIPPED    **251**

CARBIDE GRADE	HARDNESS	HRA	91.5
	RUPTURE STRENGTH	PS.I.	377,000

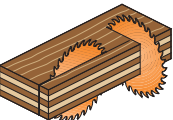
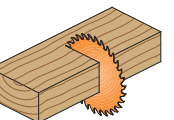
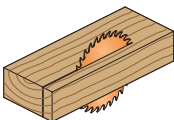
EXCELLENT Plywood  Crosscut wood  **GOOD** Rip wood 

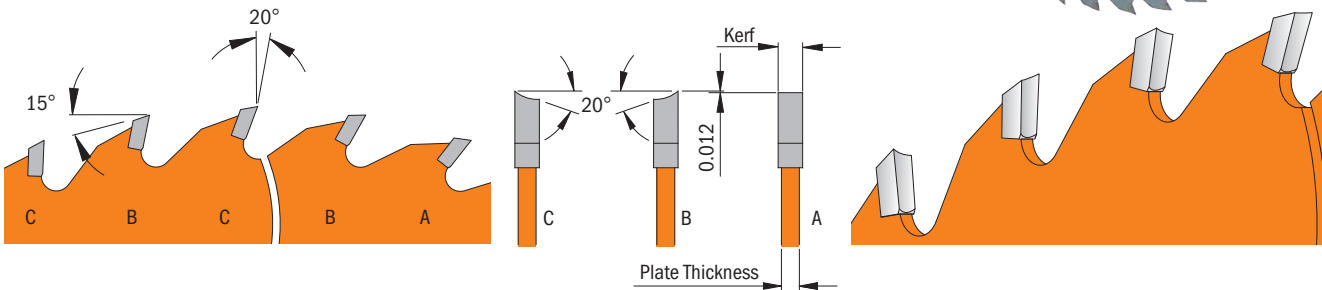

Order No.		Diameter		No. of teeth	Bore inches	Type of grind	Kerf inches	Plate inches	Hook Angle
1 pc.	Masterpack 10 pcs.	inches	mm						
251.040.07	251.040.07-X10	7-1/4	184	40	5/8 <>	20° HDF	0.071	0.047	20°

250



Our ITK Rip Blade is the workhorse rip blade for contractors. Thin Kerf design is perfect for ripping applications. The blade removes less material, putting less strain on the saw and reducing heat build up during the cut. Cooler cutting means longer life for your blade and your saw.



CARBIDE GRADE	HARDNESS	HRA	91.5
	RUPTURE STRENGTH	PS.I.	377,000

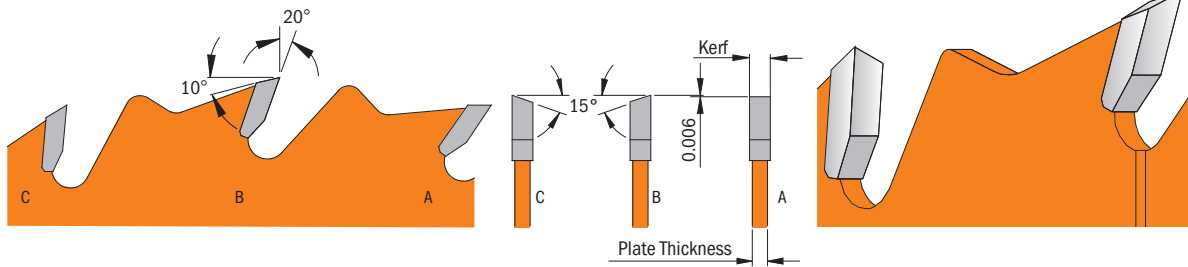
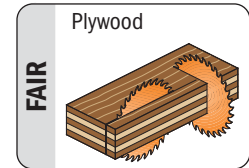
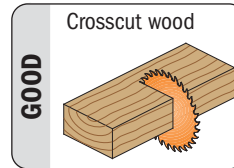
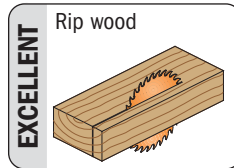

Order No.	Diameter inches	Diameter mm	No. of teeth	Bore inches	Type of grind	Kerf inches	Plate inches	Hook Angle
1 pc.								
250.024.08	8-1/4	209.5	24	5/8 <>	1FTG+2/15° ATB	0.075	0.047	20°
250.024.10	10	254	24	5/8	1FTG+2/15° ATB	0.098	0.071	20°

ITK General Purpose Blades

251



Here's an ideal choice for your all-around workhorse blade. With 42 precision ground micrograin carbide teeth in a sequence of flat top and 15° ATB grinds, it produces beautiful rip and cross cuts in a wide variety of applications.



CARBIDE GRADE	HARDNESS	HRA	93.6
	RUPTURE STRENGTH	PS.I.	334,000

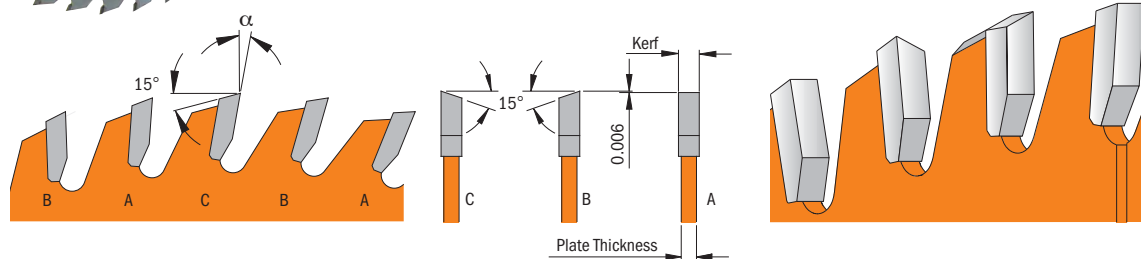
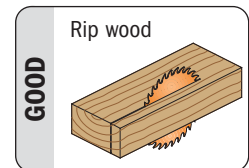
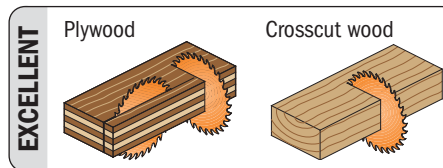

Order No.	Diameter inches	Diameter mm	No. of teeth	Bore inches	Type of grind	Kerf inches	Plate inches	Hook Angle α
1 pc.								
251.040.08	8-1/4	209.5	42	5/8 <>	1FTG+2/15° ATB	0.075	0.047	20°
251.042.10	10	254	42	5/8	1FTG+2/15° ATB	0.098	0.071	15°

The Banger Blade - excellent for general purpose cuts on the miter saw.
The Banger Blade is the contractors workhorse.



251

CARBIDE GRADE	HARDNESS	HRA	93.6
	RUPTURE STRENGTH	PS.I.	334,000

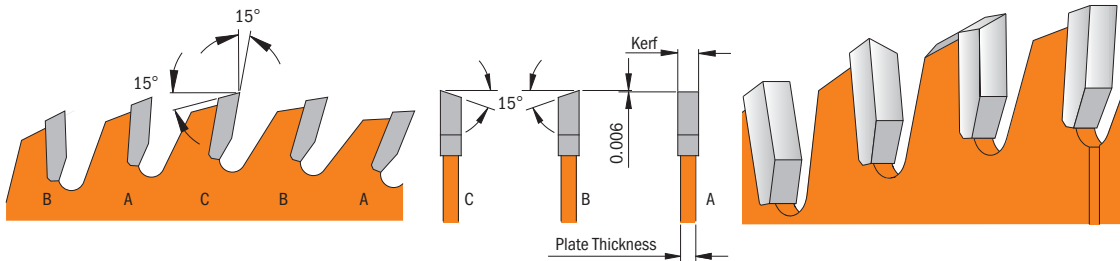
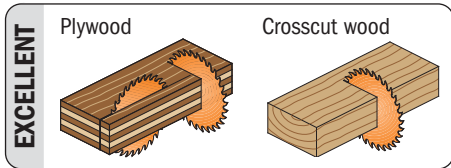

Order No. 1 pc.	Diameter inches	Diameter mm	No. of teeth	Bore inches	Type of grind	Kerf inches	Plate inches	Hook Angle
251.045.12	12	305	45	1	1FTG+2/15° ATB	0.110	0.087	15°

ITK Fine Cut-Off Blades

Our Fine Cut-Off blades are the ideal choice for extra-clean cuts and good general-purpose use on table saws.
The combination of flat top and 20° ATB teeth are perfect for crosscut, and they'll turn in a good job on the occasional rip as well.



252

CARBIDE GRADE	HARDNESS	HRA	93.6
	RUPTURE STRENGTH	PS.I.	334,000

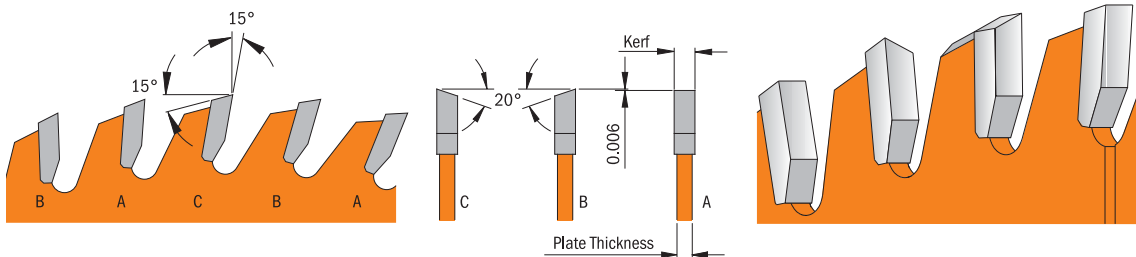
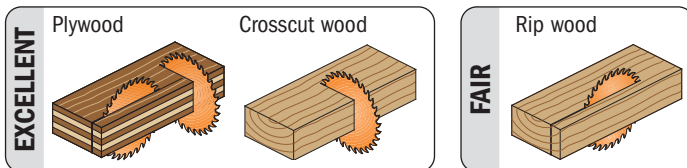

Order No. 1 pc.	Diameter inches	Diameter mm	No. of teeth	Bore inches	Type of grind	Kerf inches	Plate inches	Hook Angle
252.060.10	10	254	60	5/8	1FTG+2/20° ATB	0.098	0.071	15°
252.072.12	12	305	72	1	1FTG+2/20° ATB	0.110	0.087	15°
252.096.14	14	355	96	1	1FTG+2/20° ATB	0.110	0.087	15°

ITK Finish Compound Miter Blades



253



Specifically engineered for compound miter saws, these blades produce the ultimate glass-smooth finish on your miter cuts. Note the high tooth count on these blades - even the 8-1/2" diameter features 60 micrograin carbide teeth. We have blades for any compound miter saw, all the way up to 14" diameter!

CARBIDE GRADE	HARDNESS	HRA	93.6
	RUPTURE STRENGTH	PS.I.	334,000

EXCELLENT	Plywood	Crosscut wood	2-sided Melamine	FAIR	Rip wood

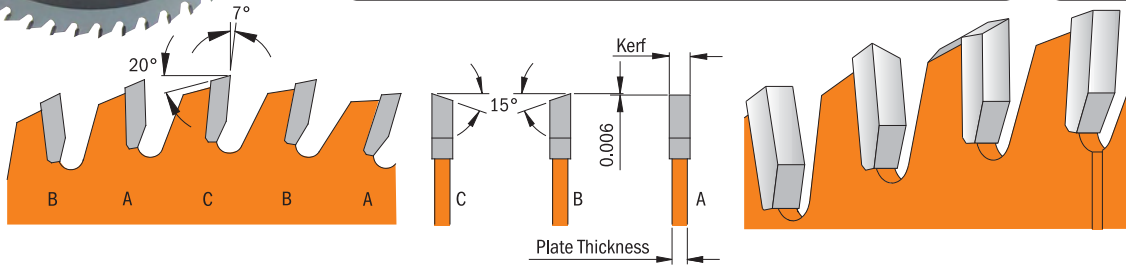

Order No. 1 pc.	Diameter inches	Diameter mm	No. of teeth	Bore inches	Type of grind	Kerf inches	Plate inches	Hook Angle
253.060.08	8-1/2	216	60	5/8	1FTG+2/15° ATB	0.087	0.055	7°
253.060.10	10	254	60	5/8	1FTG+2/15° ATB	0.098	0.071	7°
253.072.12	12	305	72	1	1FTG+2/15° ATB	0.110	0.087	7°
253.096.14	14	355	96	1	1FTG+2/15° ATB	0.110	0.087	7°

ITK Fine Finish Blades



255



Need the best possible cuts in 2-sided laminates, or crosscuts in expensive veneer with minimum waste? Need to make those cuts with speed and efficiency? Then choose our Fine Finish blades. With their razor-sharp 40° top bevel angles and precision balancing, they are the ultimate high-performance blade. This blade produces an excellent finish on hard wood as well as soft wood.

CARBIDE GRADE	HARDNESS	HRA	93.6
	RUPTURE STRENGTH	PS.I.	334,000

EXCELLENT	Plywood	Crosscut wood	2-sided Melamine	FAIR	Rip wood

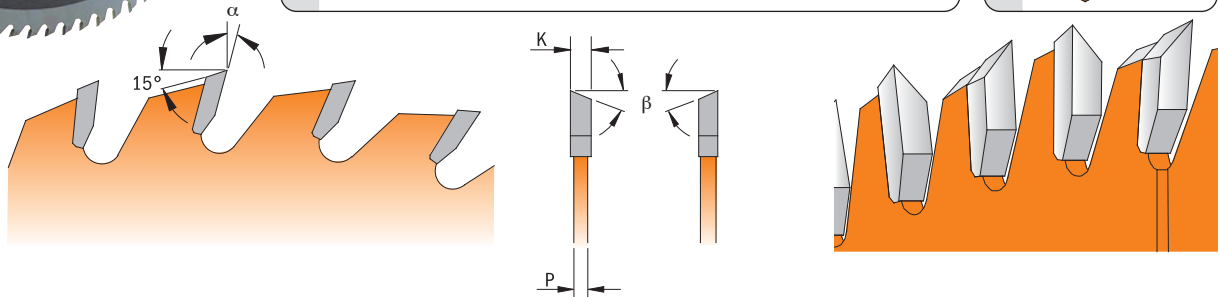

Order No. 1 pc.	Diameter inches	Diameter mm	No. of teeth	Bore inches	Type of grind	Kerf inches	Plate inches	Hook Angle
255.080.10	10	254	80	5/8	40° ATB	0.098	0.071	15°
255.096.12	12	305	96	1	40° ATB	0.110	0.087	15°

Our combination blades give you fast cuts in a wide variety of materials, without sacrificing cutting quality! Use them on the job or in your shop for beautiful cuts or clean crosscut in lumber or plywood.



256



CARBIDE GRADE	HARDNESS	HRA	91.5
	RUPTURE STRENGTH	PS.I.	377,000

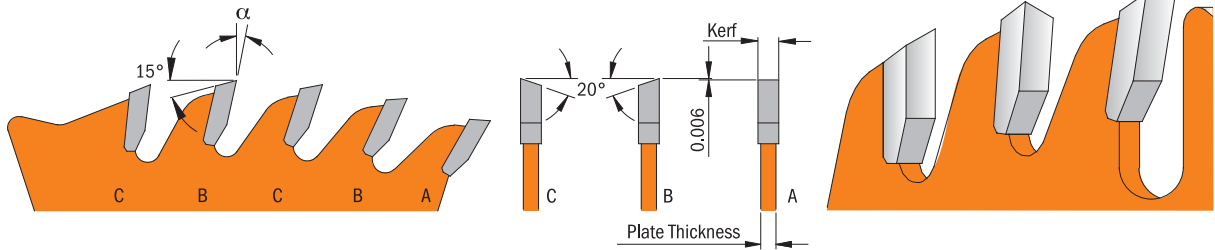
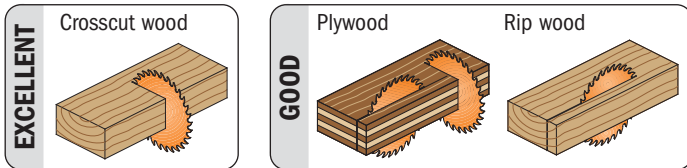

Order No.	Diameter	No. of teeth	Bore	Type of grind	Kerf	Plate	Hook Angle
1 pc.	inches		inches		inches	inches	α
256.030.07 / 256.030.07-X10	7-1/4	30	5/8 \leftrightarrow	1FTG+4/20° ATB	0.075	0.047	20°
256.035.08	8-1/4	35	5/8 \leftrightarrow	1FTG+4/20° ATB	0.075	0.047	15°
256.050.10	10	50	5/8	1FTG+4/20° ATB	0.098	0.071	15°

Ultra ITK Blades for Cordless Saws

CMT brings the performance of our Industrial Thin Kerf blades to your cordless saw! With our new Ultra Thin Kerf blades, you can produce an excellent finish anywhere you can carry a cordless saw. Available in 5-3/8" and 6-1/2" diameters in tooth configurations for a wide range of applications: ripping or crosscutting wood, PVC, non-ferrous metal and composite materials. Our Ripping/Crosscut and Fine Cut blades feature a combination of flat top and alternate top bevel teeth that deliver beautiful cuts in a wide array of stock. For non-ferrous metal, PVC and composite materials, choose the 226-series blades. Whichever you choose, you'll get a blade that gives a quality cut with the minimum stock removal and the least possible stress on your saw!



271
272
226

CARBIDE GRADE	HARDNESS	HRA	91.5
	RUPTURE STRENGTH	PS.I.	377,000

CARBIDE GRADE	HARDNESS	HRA	91.5
	RUPTURE STRENGTH	PS.I.	377,000

CARBIDE GRADE	HARDNESS	HRA	91.5
	RUPTURE STRENGTH	PS.I.	319,000

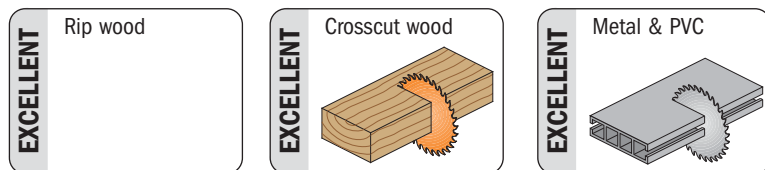

Order No.	Diameter	No. of teeth	Bore	Type of grind	Kerf	Plate	Hook Angle	Application
1 pc.	inches		inches		mm	mm	α	
271.136.18D	5-3/8	18	10mm	1FTG+2/20° ATB	1.5	1.0	20°	Rip
271.165.18	6-1/2	18	5/8	1FTG+2/20° ATB	1.3	0.8	20°	Rip
272.136.36D	5-3/8	36	10mm	1FTG+2/15° ATB	1.3	0.8	20°	Crosscut
272.165.36	6-1/2	36	5/8	1FTG+2/20° ATB	1.3	0.8	20°	Crosscut
226.030.05	5-3/8	30	10mm	TCG	1.5	1.2	0°	Metal & PVC
226.036.06	6-1/2	36	5/8	TCG	1.5	1.2	0°	Metal & PVC

230



CMT thoroughly researched the shortcomings of “standard” dado sets and learned what cabinetmakers required most from an “ideal” dado. The result was the Dado Pro Set, designed with the following features:

- Anti-kickback design to reduce the possibility of overfeeding that can occur when cutting mass material.
- Splinter resistant cuts in veneer plywood, melamine and hard and soft woods.
- Five chippers (4x1/8” - 1x1/16”) keep the cut flat and virtually free from tear out.
- Shim sets included for cuts between 1/4” and 13/16”.
- Ideal for underpowered saws.

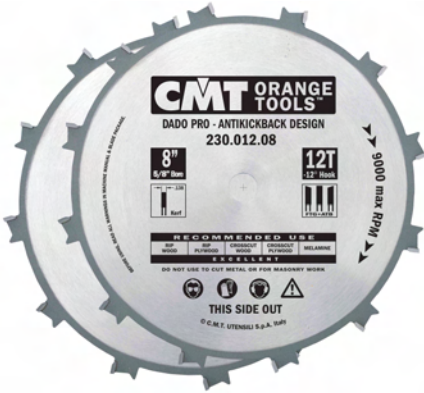

CMT's Dado Pro Set creates clean edges, square shoulders & Flat bottoms.

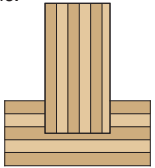

Sturdy reusable carrying case.



CMT's Dado Pro Set delivers splinter-resistant cuts in all wood, plywood and wood composites.

Slot width inches	No. Chippers Required	
	1/8	1/16
1/4	0	0
5/16	0	1
3/8	1	0
7/16	1	1
1/2	2	0
9/16	2	1
5/8	3	0
11/16	3	0
3/4	4	0
13/16	4	1

Set includes:

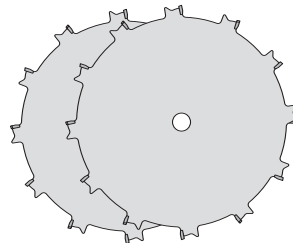

2 BLADES

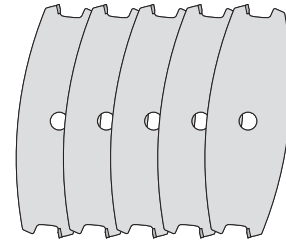

5 CARBIDE TIPPED TWO TOOTH CHIPPERS



STEEL SHIM SET

Shims set contains	
No.	Shim Width
3	0.004
2	0.008
1	0.012
1	0.020

CARBIDE GRADE	HARDNESS	HRA	91.5
	RUPTURE STRENGTH	PS.I.	377,000

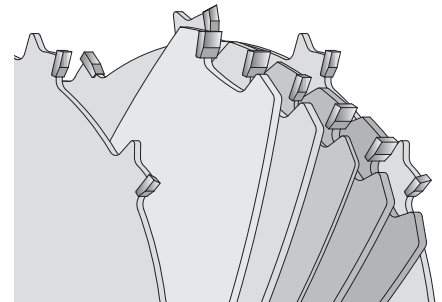
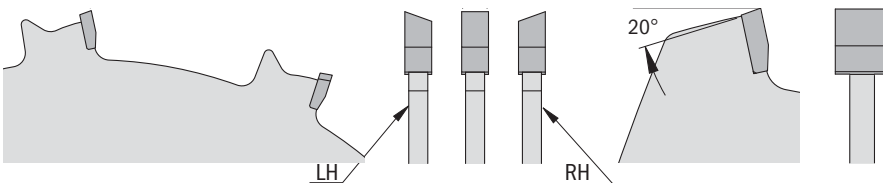

Order No. 1 pc.	Diameter inches	Diameter mm	No. of teeth	Bore inches	Chippers	Type of grind	Kerf inches	Plate inches	Hook Angle
230.012.08	8	203	12	5/8	4x1/8", 1x1/16"	FTG+ATB	0.125	0.098	-12°
spare parts:									
230.999.11	8" Dado Chipper	- 1/8"							
230.999.12	8" Dado Chipper	- 1/16"							
299.000.02	Dado Pro Steel Shim Set								

CMT's Precision Dado Sets are designed to set a new standard in performance, and they're now available in 6" or 8" diameter. The new 6" dado is perfect for smaller or somewhat underpowered table saws, like the typical 10" contractor saw. Both of these great tools offer features that make them ideal for any cabinetshop, including:

- Anti-kickback design to reduce the possibility of overfeeding that can occur when cutting mass material.
- Splinter-resistant cuts in veneer plywood, melamine and hard or soft woods.
- Four-tooth chippers that keep the cut flat & virtually free from tear out.
- 3/32" chipper made especially for undersize plywood.
- Shim sets included for cuts between 1/4" and 29/32".



230



CMT's Precision Dado Set delivers splinter-resistant cuts in all wood, plywood and wood composites.



Sturdy reusable carrying case.

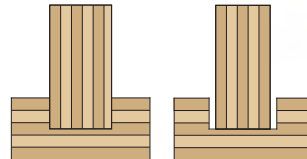

Our special 3/32" chipper lets you adjust for undersize plywood.

Slot width inches	No. Chippers Required		
	1/16	3/32	1/8
1/4	0	0	0
5/16	1	0	0
11/32	0	1	0
3/8	0	0	1
13/32	1	1	0
7/16	1	0	1
15/32	0	1	1
1/2	0	0	2
17/32	1	1	1
9/16	1	0	2
19/32	0	1	2
5/8	0	0	3
21/32	1	1	2
11/16	1	0	3
23/32	0	1	3
3/4	0	0	4
25/32	1	1	3
13/16	1	0	4
27/32	0	1	4
29/32	1	1	4

Set includes:

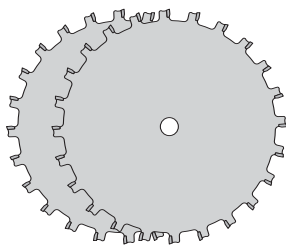

2 BLADES

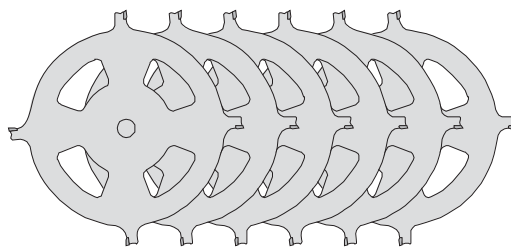

6 CARBIDE TIPPED FOUR TOOTH CHIPPERS.



STEEL SHIM SET

Shims set contains	
No.	Shim Width
4	0.004
2	0.008
2	0.012
2	0.020

CARBIDE GRADE	HARDNESS	HRA	91.5
	RUPTURE STRENGTH	PS.I.	377,000

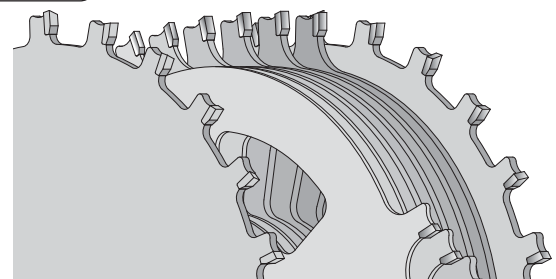
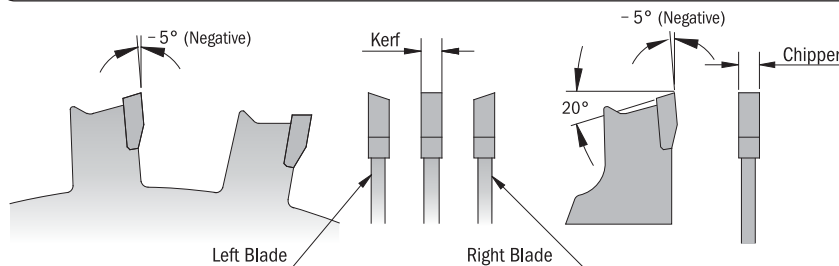

Order No. 1 pc.	Diameter inches	Diameter mm	No. of teeth	Bore inches	Chippers	Type of grind	Kerf inches	Plate inches	Hook Angle
230.520.06	6	152	20	5/8	4x1/8", 1x3/32", 1x1/16"	FTG+ATB	0.125	0.098	-5°
230.524.08	8	203	24	5/8	4x1/8", 1x3/32", 1x1/16"	FTG+ATB	0.125	0.098	-5°
spare parts:	230.999.21	8" Dado Chipper - 1/8"			230.999.16	6" Dado Chipper - 1/8"			
	230.999.22	8" Dado Chipper - 3/32"			230.999.17	6" Dado Chipper - 3/32"			
	230.999.23	8" Dado Chipper - 1/16"			230.999.18	6" Dado Chipper - 1/16"			
					299.000.03	Precision Dado STEEL Shim Set			

ORANGE PTFE NON-STICK COATING – we know it is eye-catching, as well as being part of the CMT orange tools trademark, there's a lot more to this orange PTFE non-stick coating than just making the blade look good. So, what does it do?

IT KEEPS THE BLADE CLEAN – they call it non-stick for a reason. Cut wood releases natural resins and pitch and creates wood dust, all of which can easily stick to on an uncoated blade. Before long these substances build up on the blade and keep it from making a clean cut, causing a good deal of friction between the blade and the wood. The result is an over-worked blade and scorching on the wood. With PTFE non-stick coating, these wood residues don't stick – it's as simple as that. And the blade stays clean, cut after cut.

IT KEEPS THE BLADE RUST-PROOF – oxidization – better known as rust - can cause the same problems as residue build-up. Rust inhibits blade performance by increasing blade drag and causing the saw motor to work extra hard. CMT's orange PTFE non-stick coating seals humidity away from the steel plate to block oxidization and help extend the life of the blade.

IT KEEPS THE BLADE COOL – the contact between the rotating steel blade and the wood creates a substantial amount of friction, and friction causes heat. The slick PTFE non-stick coating on the blade cuts cleaner and quicker and reduces the amount of friction, thus reducing the amount of heat generated during cutting.

IT KEEPS THE BLADE SHARP – by reducing friction, not only does a blade with PTFE non-stick coating keep the blade cooler, but it keeps it sharper too. Less stress on the blade means easier cutting. Your blade works more efficiently and therefore stays sharper longer.

Saw Blade Safety Precautions:

- ALWAYS** thoroughly check all blades for damage and flaws before using. Do not use blades with missing or damaged teeth.
- ALWAYS** wear safety glasses and ear protection when using power tools.
- ALWAYS** thoroughly read the owners manual and manufacturer's instructions before working with tools.
- ALWAYS** use a fence and splitter when using the table saw. Do not make freehand cuts.
- ALWAYS** use pusher blocks or a pusher stick, especially when working with small or narrow pieces.
- ALWAYS** unplug your saw before cleaning or adjusting the tool, or before making blade changes.
- ALWAYS** keep your tools sharpened, clean and stored in a safe place to avoid breakage and accidents and to extend the life of your bits and blades.
- ALWAYS** feed the work against the rotation of the blade on table saws.
- ALWAYS** be sure your workpiece is completely supported, before and after the cut.

- NEVER** remove guards from radial arm saws and miter saws.
- NEVER** remove the splitter or anti-kickback devices from table saws.
- NEVER** use dull or damaged blades.
- NEVER** use blades with missing or chipped teeth.
- NEVER** force the cut or overload the saw.
- NEVER** change blades with the saw plugged in.
- NEVER** make adjustments to any saw while the blade is turning.

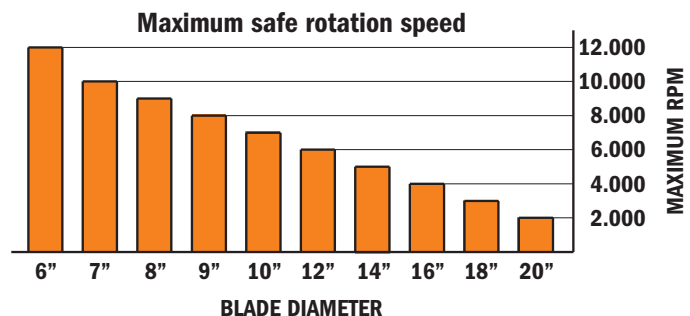

Large flat top teeth with an aggressive 20° hook make this a great blade for glue line rips, even with a power feed, in hard or soft wood.



**201
202**

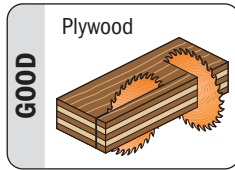
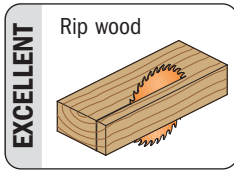

CARBIDE GRADE	HARDNESS	HRA	91.5
	RUPTURE STRENGTH	PS.I.	377,000

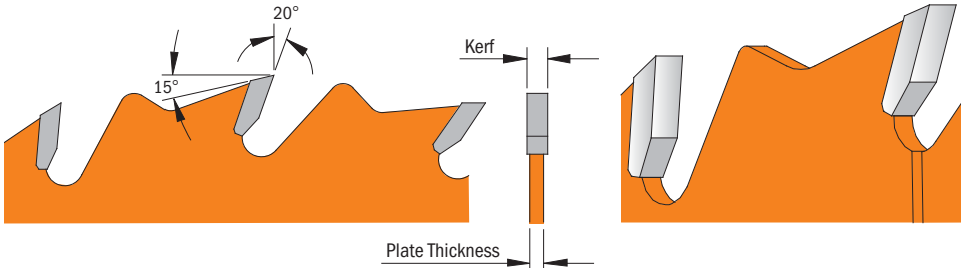
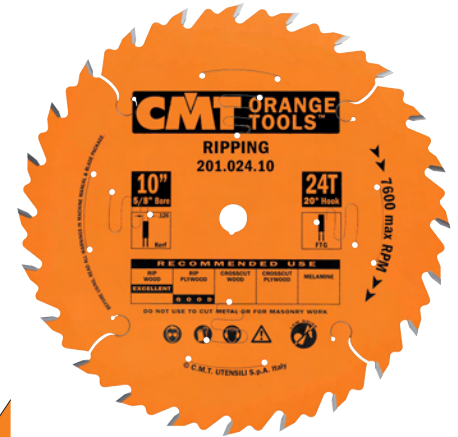

Order No. 1 pc.	Diameter inches	mm	No. of teeth	Bore inches	Type of grind	Kerf inches	Plate inches	Hook Angle
201.020.08	8	203	20	5/8 <>	FTG	0.126	0.087	20°
201.024.10	10	254	24	5/8 <>	FTG	0.126	0.087	20°
201.030.12	12	305	30	1	FTG	0.126	0.087	20°
<i>Thin-Kerf</i>								
202.024.10	10	254	24	5/8	FTG	0.094	0.063	20°

Glue Line Ripping Blades

The new triple chip teeth design makes this CMT rip blade ideal for glue line rips in hard and soft woods. These blades are equipped with a special anti-kickback shoulder behind each tooth to minimize the possibility of dangerous kickback that can occur as a result of overfeeding. This blade will produce a perfect cut eliminating the need for sanding. Ideal for power or hand feeding.



203

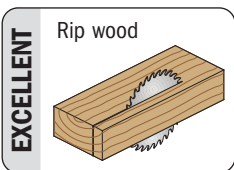

CARBIDE GRADE	HARDNESS	HRA	92.7
	RUPTURE STRENGTH	PS.I.	334,000

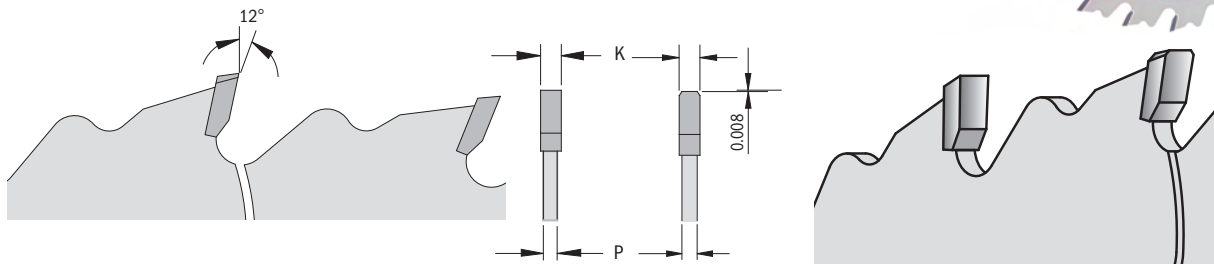

Order No. 1 pc.	Diameter inches	mm	No. of teeth	Bore inches	Type of grind	Kerf inches	Plate inches	Hook Angle
203.030.08	8	203	30	5/8	1TCG+1FTG	0.126	0.087	12°
203.030.10	10	254	30	5/8	1TCG+1FTG	0.126	0.087	12°
203.036.12	12	305	36	1	1TCG+1FTG	0.165	0.110	12°
203.036.14	14	355	36	1	1TCG+1FTG	0.165	0.110	12°

Cut Off ATB Blades



**205
206**



Our cut off ATB blades are THE choice for all-round cut off applications in hardwood, softwood or plywood. They feature 60 carefully ground 20° ATB teeth and a 5° hook, so these blade are great for use in your miter or table saw.

CARBIDE GRADE	HARDNESS	HRA	93.6
	RUPTURE STRENGTH	PS.I.	334,000

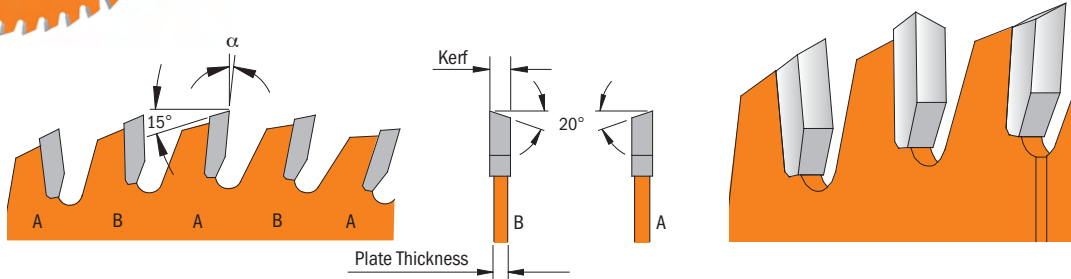
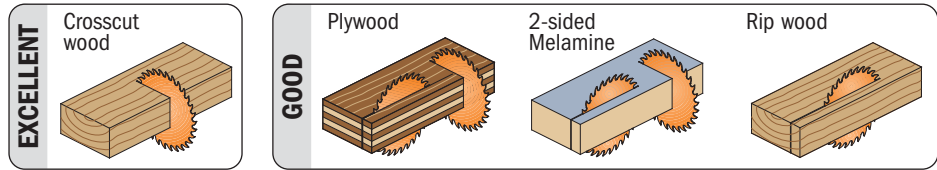

Order No. 1 pc.	Diameter inches	Diameter mm	No. of teeth	Bore inches	Type of grind	Kerf inches	Plate inches	Hook Angle α
205.060.10 <i>Thin-Kerf</i>	10	254	60	5/8	20° ATB	0.102	0.079	5°
206.060.10	10	254	60	5/8	20° ATB	0.094	0.063	15°

Cut Off Blades



208



Our fast-cutting 15° hook delivers the speed and efficiency you need, along with a very clean cut when crosscutting a wide variety of materials. In addition to a laser-cut 5/8" arbor, these blades also include a diamond knockout.

CARBIDE GRADE	HARDNESS	HRA	92.7
	RUPTURE STRENGTH	PS.I.	334,000

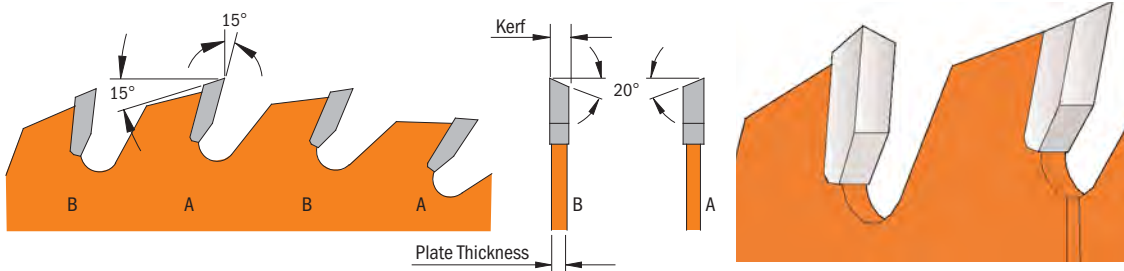
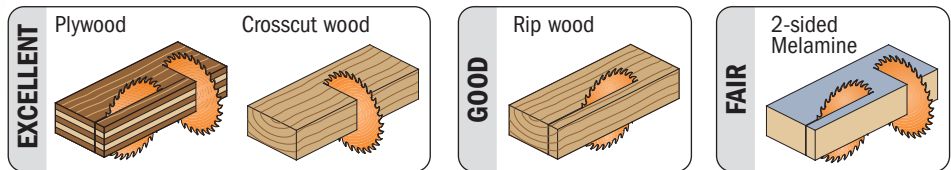

Order No. 1 pc.	Diameter inches	Diameter mm	No. of teeth	Bore inches	Type of grind	Kerf inches	Plate inches	Hook Angle
208.040.07	7-1/4	184	40	5/8 <>	20° ATB	0.091	0.059	15°
208.040.08	8	203	40	5/8	20° ATB	0.102	0.063	15°

Here is the fine finish carpenter's first choice for a sliding compound miter saw. These blades give you the widest range of cuts with your saw, and they feature a 5° negative hook to limit splintering and "climbing".



219

CARBIDE GRADE	HARDNESS	HRA	93.6
	RUPTURE STRENGTH	PS.I.	334,000

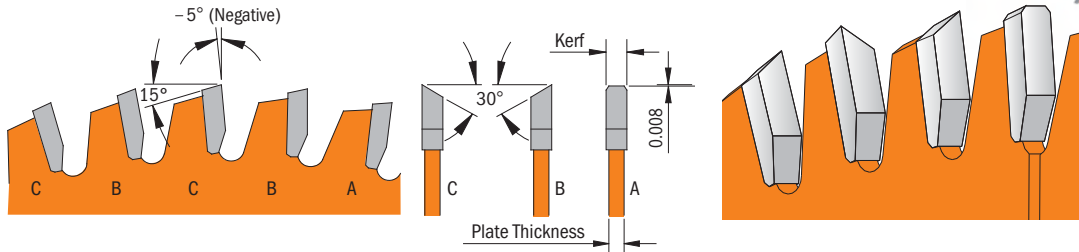
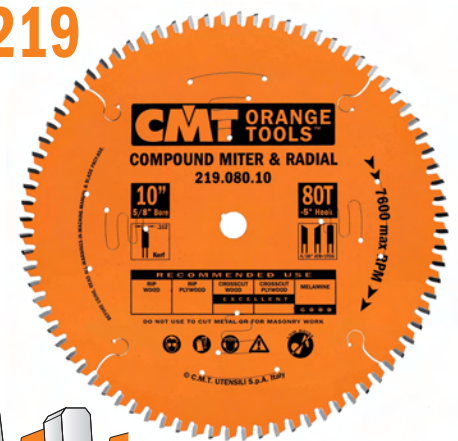
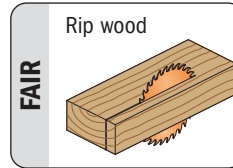
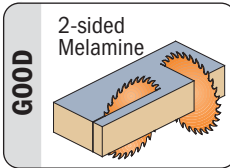
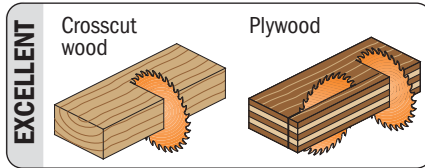

Order No. 1 pc.	Diameter inches	Diameter mm	No. of teeth	Bore inches	Type of grind	Kerf inches	Plate inches	Hook Angle
219.060.08	8-1/2	216	60	5/8	4ATB+1TCG	0.118	0.098	-5°
219.080.10	10	254	80	5/8	4ATB+1TCG	0.118	0.098	-5°
219.090.12	12	305	90	1	4ATB+1TCG	0.118	0.098	-5°
219.100.14	14	355	100	1	4ATB+1TCG	0.118	0.098	-5°
219.100.15	15	380	100	1	4ATB+1TCG	0.118	0.098	-5°
219.110.16	16	406	110	1	4ATB+1TCG	0.118	0.098	-5°

Compound Miter Blades

We only offer this blade in one diameter because it's only designed for one saw - your 8-1/2" compound miter saw. The 5° negative hook and 20° ATB teeth are perfectly suited to your Hitachi C8FB or similar tool.



207

CARBIDE GRADE	HARDNESS	HRA	93.6
	RUPTURE STRENGTH	PS.I.	334,000

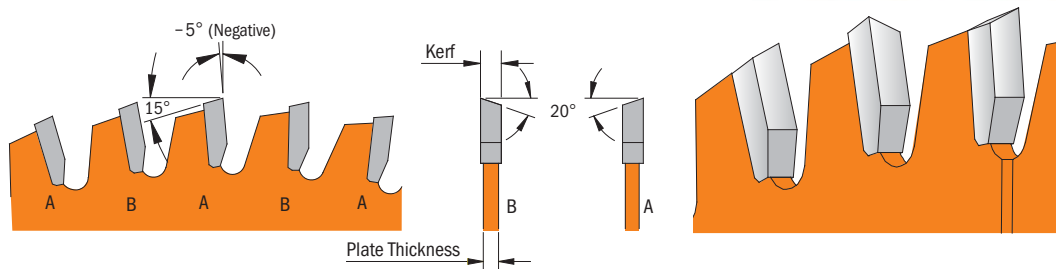
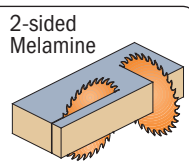
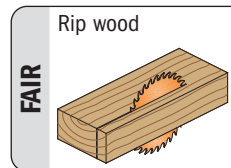
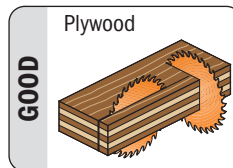
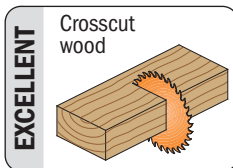

Order No. 1 pc.	Diameter inches	Diameter mm	No. of teeth	Bore inches	Type of grind	Kerf inches	Plate inches	Hook Angle
207.048.08	8-1/2	216	48	5/8	20° ATB	0.110	0.071	-5°



213-214



The first choice for all-around performance.

The General is the ultimate multi application tablesaw blade. CMT's unique design uses ATB teeth and an 18° hook the give you beautiful rips and crosscuts on your table saw.

CARBIDE GRADE **HARDNESS HRA** **92.7**

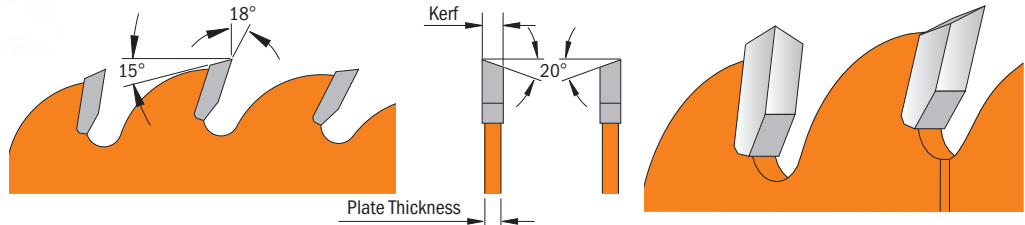
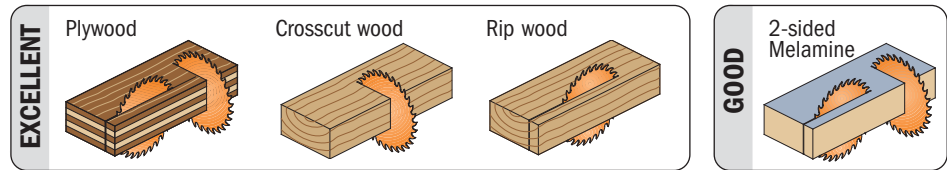

Order No. 1 pc.	Diameter inches	Diameter mm	No. of teeth	Bore inches	Type of grind	Kerf inches	Plate inches	Hook Angle
213.040.10	10	254	40	5/8	20° ATB	0.126	0.098	18°
<i>Thin-Kerf</i>								
214.040.10	10	254	40	5/8	20° ATB	0.102	0.071	18°

Combination Blades



215-216



Our special design features a triple chip grind on every fifth tooth. This tooth cleans out excess material as you cut, delivering a finish that ordinary combination blades simply can't touch!

CARBIDE GRADE **HARDNESS HRA** **92.7**
RUPTURE STRENGTH **PS.I.** **334,000**

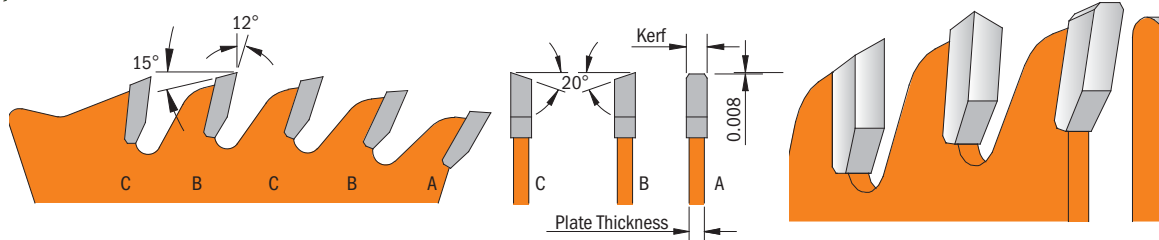
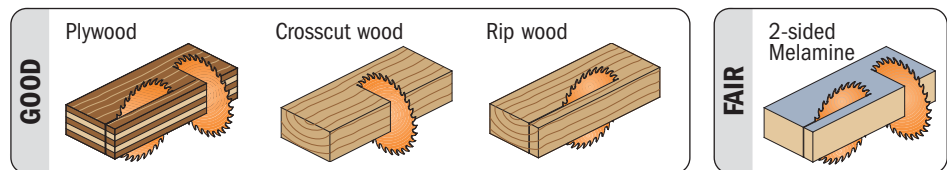

Order No. 1 pc.	Diameter inches	Diameter mm	No. of teeth	Bore inches	Type of grind	Kerf inches	Plate inches	Hook Angle
215.040.08	8	203	40	5/8	4ATB+1TCG	0.126	0.087	12°
215.050.10	10	254	50	5/8	4ATB+1TCG	0.126	0.087	12°
215.060.12	12	305	60	1	4ATB+1TCG	0.126	0.087	12°
215.070.14	14	355	70	1	4ATB+1TCG	0.138	0.098	12°
<i>Thin-Kerf</i>								
216.050.10	10	254	50	5/8	4ATB+1TCG	0.094	0.063	12°

The ultimate blade for cutting melamine and veneer, thanks to an incredibly sharp 40° top bevel angle that lets these teeth produce a flawless finish in 2-sided material. This blade is also a great choice for “chop” - style miter saws.



210



CARBIDE GRADE	HARDNESS	HRA	93.6
	RUPTURE STRENGTH	PS.I.	334,000

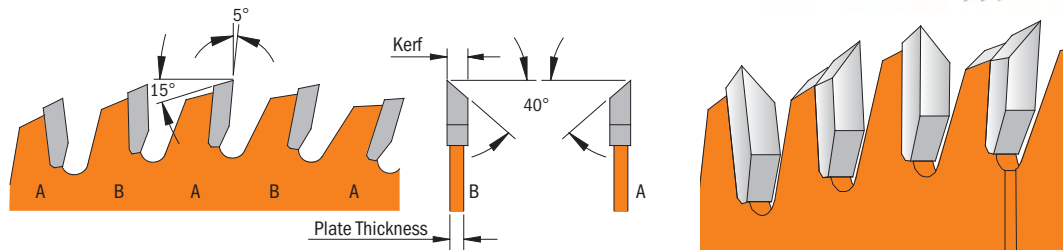
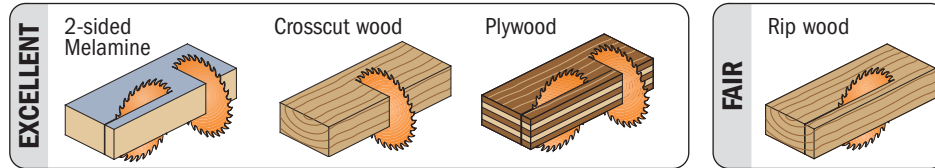

Order No. 1 pc.	Diameter inches	Diameter mm	No. of teeth	Bore inches	Type of grind	Kerf inches	Plate inches	Hook Angle
210.060.08	8	216	60	5/8	40° ATB	0.126	0.087	5°
210.080.10	10	254	80	5/8	40° ATB	0.126	0.087	5°
210.096.12	12	305	96	1	40° ATB	0.126	0.087	5°

Cabinetshop Blades

We decided to call this blade the “Cabinetshop Blade” because that is precisely what it is! A combination of triple-chip and flat ground teeth make this a great choice for plywood, laminates, hardwood or softwood. **Also performs very well in solid surface materials!**



221



CARBIDE GRADE	HARDNESS	HRA	93.6
	RUPTURE STRENGTH	PS.I.	334,000

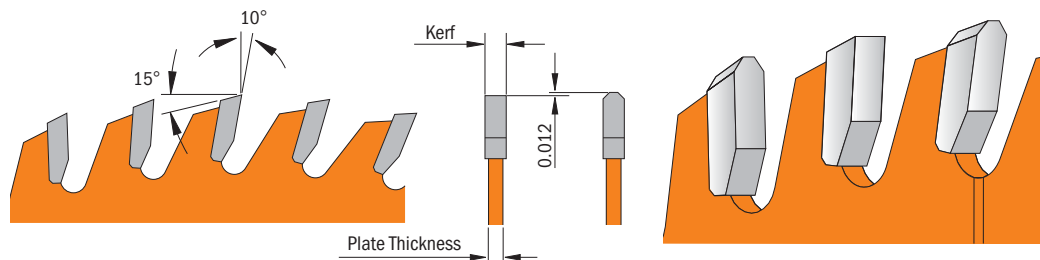
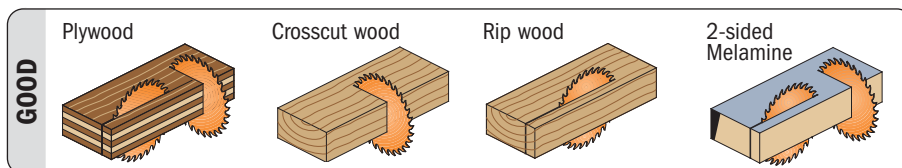

Order No. 1 pc.	Diameter inches	Diameter mm	No. of teeth	Bore inches	Type of grind	Kerf inches	Plate inches	Hook Angle
221.060.10	10	254	60	5/8	1TCG+1FTG	0.126	0.087	10°
221.072.12	12	305	72	1	1TCG+1FTG	0.126	0.087	10°

281



This new Multi-Purpose blade with trapezoidal tooth and special expansion slots, allow you to make a good crosscut on all kinds of wood and plywood. Good performance is guaranteed on laminates and chipboard making the ideal Multi-Purpose blade.



CARBIDE GRADE	HARDNESS	HRA	93.6
	RUPTURE STRENGTH	PS.I.	334,000

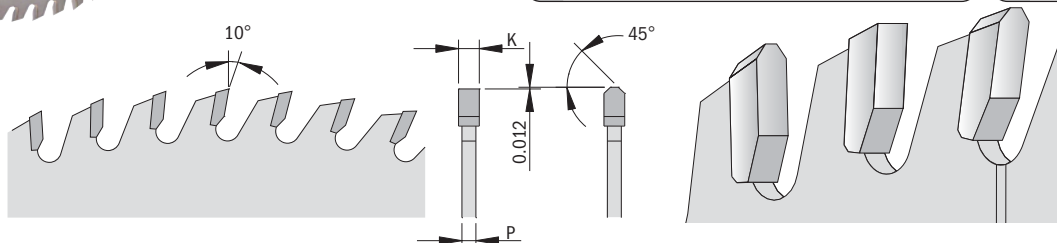
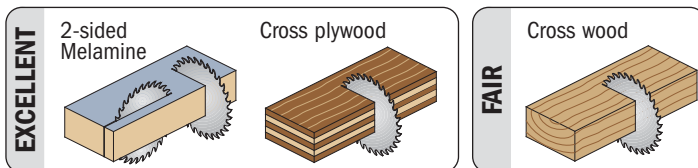

Order No. 1 pc.	Diameter inches	Diameter mm	No. of teeth	Bore inches	Type of grind	Kerf inches	Plate inches	Hook Angle
281.060.10	10	254	60	5/8	TCG	0.126	0.087	10°
281.072.12	12	305	72	1	TCG	0.126	0.087	10°
281.084.14	14	355	84	1	TCG	0.157	0.110	10°
281.096.16	16	406	96	1	TCG	0.157	0.110	10°

Non-Ferrous Metal, PVC & Melamine Blades

225



Our Non-Ferrous Metal Saw Blades are ideal for miter, radial and table saws and give optimum performance cutting aluminum, brass and other non-ferrous metals. They feature high-impact-strength carbide teeth, triple chip tooth configuration and a unique gullet design that allows efficient chip evacuation.

The close tooth-to-body ratio: 0.112 tooth to 0.098 blade plate - gives better support to the tooth, and the -7° hook angle provides controlled cutting for a smooth finish without collapsing channel or storm window frames.

NOTE: We highly recommend using a liquid lubricant. Wax stick for lubrication NOT RECOMMENDED.

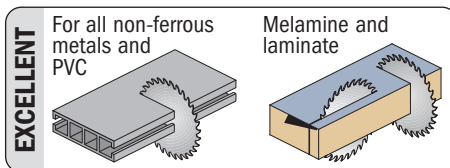

CARBIDE GRADE	HARDNESS	HRA	92.7
	RUPTURE STRENGTH	PS.I.	312,000

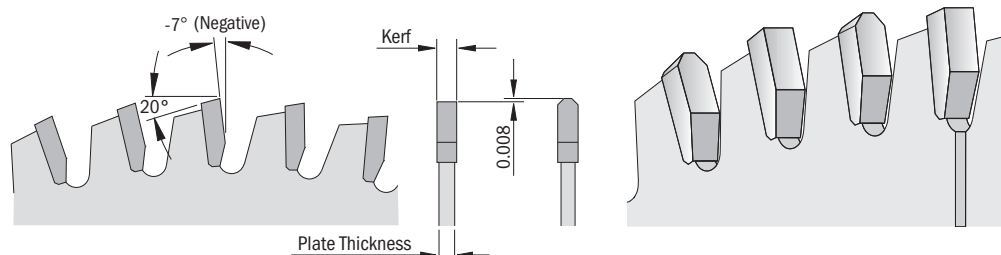

Order No. 1 pc.	Diameter inches	Diameter mm	No. of teeth	Bore inches	Type of grind	Kerf inches	Plate inches	Hook Angle
225.060.08	8-1/2	216	60	5/8	1TCG+1FTG	0.122	0.098	-7°
225.080.10	10	254	80	5/8	1TCG+1FTG	0.122	0.098	-7°
225.096.12	12	305	96	1	1TCG+1FTG	0.122	0.098	-7°
225.108.14	14	355	108	1	1TCG+1FTG	0.122	0.098	-7°

Our new selection of dry cut blades are perfect for almost all metal chop saws such as Jepsen machines. We've combined unique tooth geometry with the finest micrograin carbide, resulting in a tool that delivers outstanding cut quality. Use our dry cut blades in iron, steel, stainless steel, pipe, sheet metal, brass or aluminum. Or use the same blade to cut sandwich panels for aluminum doors and windows, PVC, melamine, wood and more!



226



CARBIDE GRADE	HARDNESS HRA	91.5
	RUPTURE STRENGTH PS.I.	319,000

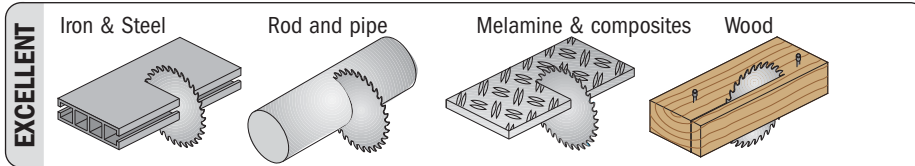

DiameterMax. RPM
5-3/8"5500
6-1/2"4600
7-1/4"3000
10"3000
12"2500
14"2100

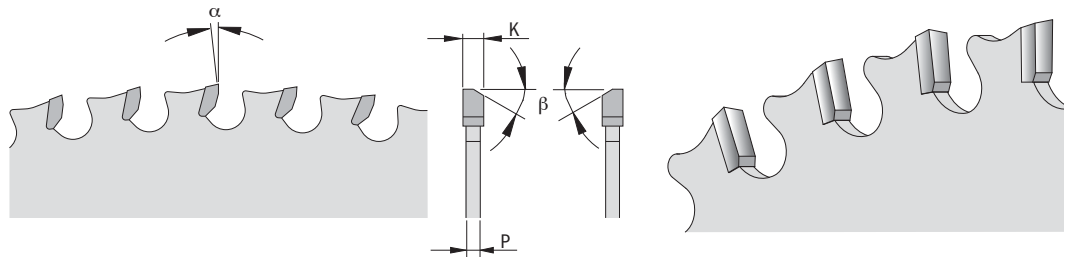

Order No. 1 pc.	Diameter inches	Diameter mm	No. of teeth	Bore inches	Type of grind	Kerf inches	Plate inches	Hook Angle α
226.030.05	5-3/8	136	30	10mm	TCG	0.059	0.047	10°
226.036.06	6-1/2	165	36	5/8	TCG	0.059	0.047	10°
226.048.07	7-1/4	184	48	5/8 <>	TCG	0.079	0.063	10°
226.048.08	8-1/4	203	48	5/8 <>	TCG	0.087	0.071	10°
226.060.10	10	254	60	5/8	5° FWF	0.087	0.071	0°
226.060.12	12	305	60	1	5° FWF	0.087	0.071	0°
226.080.12	12	305	80	1	5° FWF	0.087	0.071	0°
226.080.14	14	355	80	1	5° FWF	0.087	0.071	0°
226.090.14	14	355	90	1	5° FWF	0.087	0.071	0°

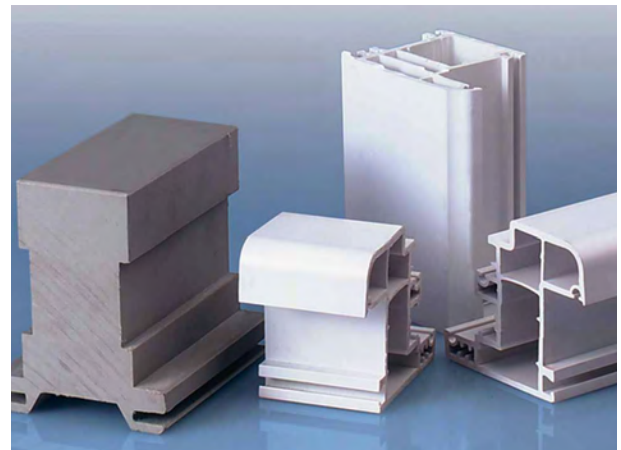
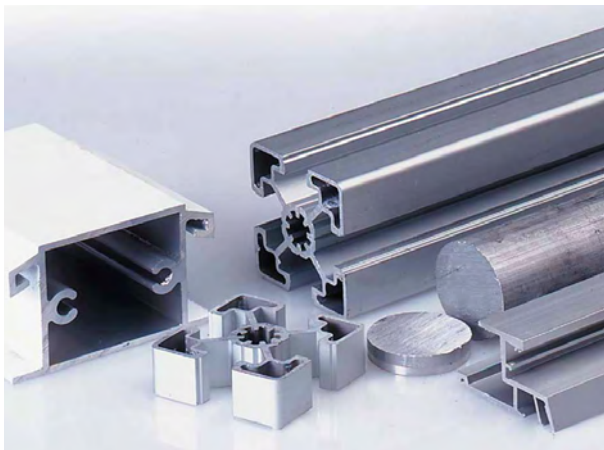

Solid Surface Blades

new

CMT ORANGE TOOLS™

223

CARBIDE TIPPED



CMT has produced an innovative modified triple chip grind (MTCG) combined with a specialized micrograin carbide formulation for swirl free cuts in solid surface materials. This blade is ideal for solid surface materials that include: **DuPont Corian®**, **Wilsonart Gibraltar®**, **SSV Fountainhead®** and **Varicor®**. This blade is also ideal for cutting thick plastic for a melt free smooth finish.

Safety Precautions: Not recommended for use on miter saws.

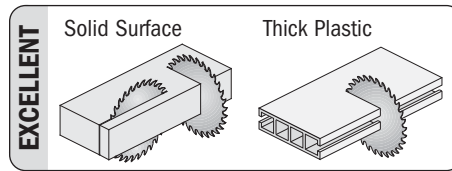

CARBIDE GRADE	HARDNESS	HRA	93.6
	RUPTURE STRENGTH	P.S.I.	334,000

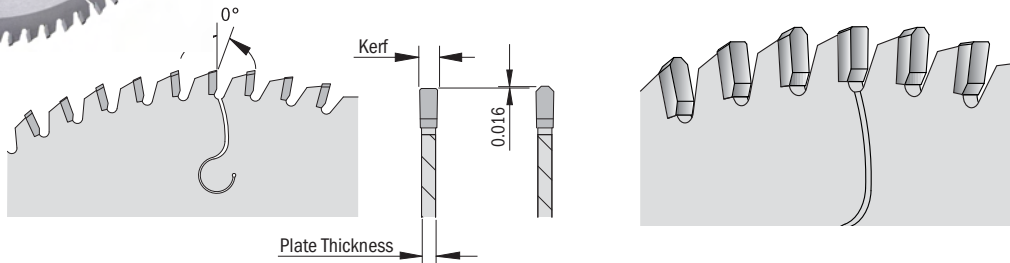

Order No. 1 pcs.	Diameter inches	Diameter mm	No. of teeth	Bore inches	Type of grind	Kerf inches	Plate inches	Hook Angle
223.072.10	10	254	72	5/8	MTCG	0.126	0.098	0°
223.084.12	12	305	84	1	MTCG	0.126	0.098	0°
223.096.14	14	355	96	1	MTCG	0.126	0.098	0°

Plexiglass and Plastic Blades

new

222

CARBIDE TIPPED



This innovative industrial saw blade employs a special modified alternate top bevel grind (MATB) and a unique micro grain carbide formulation that allows it to cut plastics and plexiglass without melting!

The blade gives excellent results in thin plastic, plexiglass, vinyl, plywood and laminated flooring and good results in thick plastic and laminates.

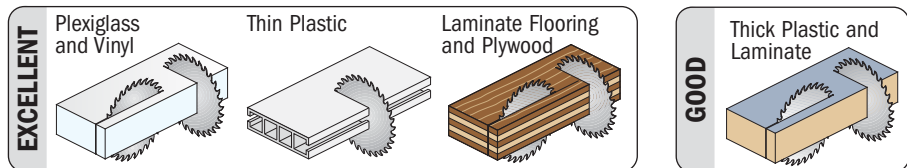

CARBIDE GRADE	HARDNESS	HRA	93.6
	RUPTURE STRENGTH	P.S.I.	334,000

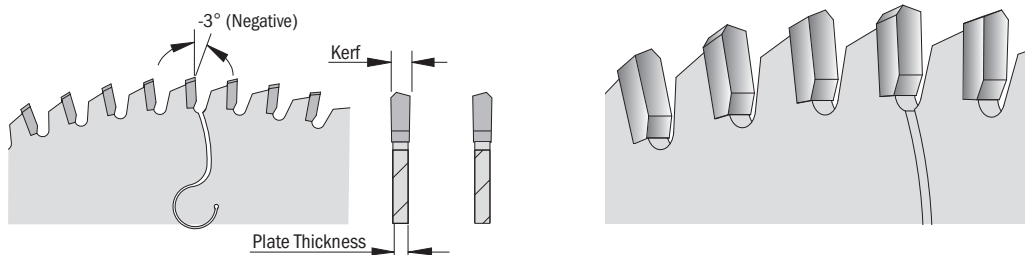

Order No. 1 pcs.	Diameter inches	Diameter mm	No. of teeth	Bore inches	Type of grind	Kerf inches	Plate inches	Hook Angle
222.064.08	8	203	64	5/8	MATB	0.110	0.087	-3°
222.080.10	10	254	80	5/8	MATB	0.110	0.087	-3°
222.096.12	12	305	96	1	MATB	0.110	0.087	-3°
222.108.14	14	355	108	1	MATB	0.110	0.087	-3°

These are the best choice for cut off work in fine, delicate materials such as 2-sided laminates and veneers. The extra-high 40° top level angle produces the absolute minimum of chipping on both surfaces.



283

CARBIDE GRADE	HARDNESS	HRA	93.6
	RUPTURE STRENGTH	PS.I.	334,000

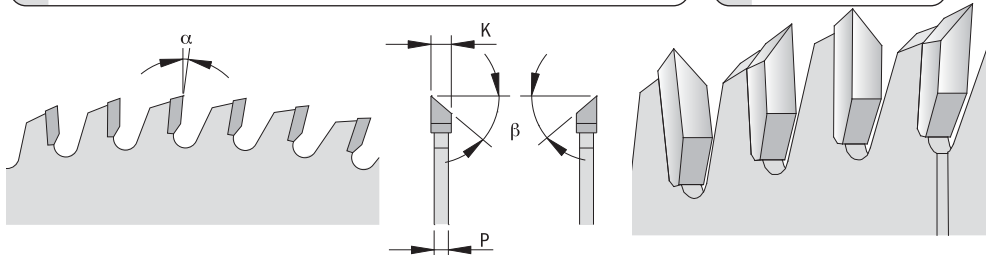
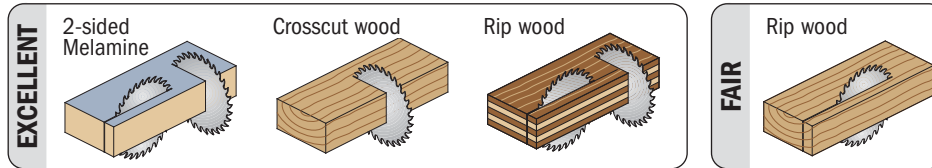

Order No. 1 pc.	Diameter mm	No. of teeth	Bore mm	Pin Hole	Type of grind	Kerf mm	Plate mm	Hook Angle α
283.064.09M	220	64	30	2/7/42	40° ATB	3.2	2.2	-5°
283.080.10M	250	80	30	2/10/60+2/7/42	40° ATB	3.2	2.2	-2°
283.096.12M	300	96	30	2/10/60+2/7/42	40° ATB	3.2	2.2	2°
283.108.14M	350	108	30	2/10/60+2/7/42	40° ATB	3.5	2.5	5°

Crosscut and Finish Blades

These are extremely versatile blades, delivering fast, efficient cuts in a wide variety of materials. Use them in hard or soft wood or plywood. They feature alternate top level teeth and an aggressive 15° hook.



285

CARBIDE GRADE	HARDNESS	HRA	93.1
	RUPTURE STRENGTH	PS.I.	298,000

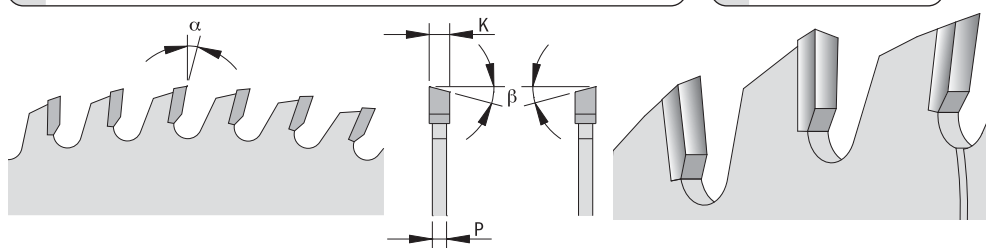
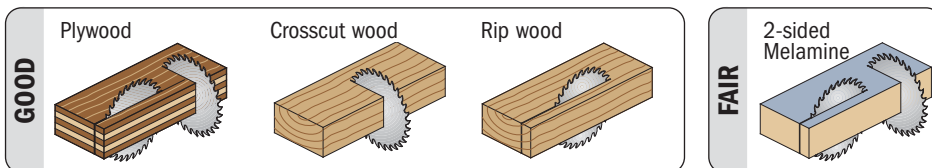

Order No. 1 pc.	Diameter mm	No. of teeth	Bore mm	Pin Hole	Type of grind β	Kerf mm	Plate mm	Hook Angle α
Crosscut blades								
285.040.10M	250	40	30	2/10/60+2/7/42	10° ATB	3.2	2.2	15°
285.048.12M	300	48	30	2/10/60+2/7/42	10° ATB	3.2	2.2	15°
285.054.14M	350	54	30	2/10/60+2/7/42	10° ATB	3.5	2.5	15°
Finish blades								
285.060.10M	250	60	30	2/10/60+2/7/42	15° ATB	3.2	2.2	10°
285.072.12M	300	72	30	2/10/60+2/7/42	15° ATB	3.2	2.2	10°
285.072.14M	350	72	30	2/10/60+2/7/42	10° ATB	3.5	2.5	15°

Panel Sizing Saw Blades

Diameter mm	Bore mm	Pin Hole	No. of teeth	Kerf thickness	Type of grind	Panel Sizing Saw Blade	Machine	Diameter mm	Bore mm	No. of teeth	Kerf thickness	Conical Scoring Blade
300	30	2+2	96	3,2	TCG	281.096.12M	ALTENDORF F45, WA80	120	22	24	3,1-4,0	288.120.24K
400	60	2	72	4,4	TCG	Y282.072.16U	ANTHON LN90, LNA100, PORTA100	180	20	36	4,3-5,5	Y288.160.3602
500	60	2	72	4,8	TCG	282.072.20U	PORTA150, LNB150					
300	30		60	4,4	TCG	282.060.12M	CASADEI MX, CX, SX, SV	125	20	24	4,3-5,5	288.125.24H2
350	30	4	72	4,4	TCG	282.072.14M	MX, CX, SX, SV	125	20	24	4,3-5,5	288.125.24H2
300	80	4+2+2	60	4,4	TCG	282.060.12W	GABBIANI GMS	160	55	36	4,3-5,5	288.160.360
350	80	4+2+2	72	4,4	TCG	282.072.14W	GMS 10-30-40-50	160	55	36	4,3-5,5	288.160.360
400	80	4+2+2	72	4,4	TCG	282.072.16W	GMS 10-30-40-50	160	55	36	4,3-5,5	288.160.360
500	80	4+2+2	72	4,8	TCG	Y282.072.20W		160	55	36	4,7-6,0	Y288.160.3602
300	75	4	60	4,4	TCG	282.060.12X	GIBEN FASTMATIC	125	45	24	4,3-5,5	288.125.24Q
350	75	4	72	4,4	TCG	282.072.14X	MK, GAMMA N, ST, SE, TREND, MK2	125	45	24	4,3-5,5	288.125.24Q
400	75	4	72	4,4	TCG	282.072.16X	G2000	125	45	24	4,3-5,5	288.125.24Q
400	75	4	72	4,4	TCG	282.072.16X	PRIMASTIC 101	160	45	36	4,3-5,5	288.160.36Q
400	75	4	72	4,4	TCG	282.072.16X	PRIMASTIC 201	215	50	42	4,3-5,5	288.215.42T
430	75	4	72	4,4	TCG	282.072.17X	PRIMASTIC 201	300	50	48	4,3-5,5	288.300.48T
550	100		72	5,2	TCG	282.072.22A	FASTMATIC	180	55	36	5,0-6,2	288.180.36Q
300	30		60	4,4	TCG	282.060.12M	HÖFER PS	180	20	36	4,3-5,5	Y288.180.36H
350	30	4+2+2	72	4,4	TCG	282.072.14M	PM	200	20	36	4,3-5,5	288.200.36H
400	30		72	4,4	TCG	282.072.16M	PM	200	20	36	4,3-5,5	288.200.36H
380	60		72	4,8	TCG	Y282.072.15U	HOLZMA HPP 81, HPL 81, 91	200	45	36	4,7-6,0	288.200.36Q
450	60		72	4,8	TCG	282.072.18U	HPP 11	180	45	36	4,7-6,0	288.180.36Q
500	60	2	72	4,8	TCG	282.072.20U	TYP 22	200	45	36	4,7-6,0	288.200.36Q
300	75	4	60	4,4	TCG	282.060.12X	HOMAG CH03	125	45	24	4,3-5,5	288.125.24Q
300	75	4	60	4,4	TCG	282.060.12X	CH04, CH06/10	150	45	36	4,3-5,5	288.150.36Q
400	75	4	72	4,4	TCG	282.072.16X	CH12	150	45	36	4,3-5,5	288.150.36Q
300	30		60	4,4	TCG	282.060.12M	MAYER	125	45	24	4,3-5,5	288.125.24Q
350	30	4	72	4,4	TCG	282.072.14M		125	45	24	4,3-5,5	288.125.24Q
400	30		72	4,4	TCG	282.072.16M		125	45	24	4,3-5,5	288.125.24Q
250	30		60	3,2	TCG	281.060.10M	PANHANS EURO 5, EURO 5 SFV	125	20	24	3,1-4	288.125.24K
300	30		60	4,4	TCG	282.060.12M	693/SH/SO	125	20	24	4,3-5,5	288.125.24H2
300	30		60	4,4	TCG	282.060.12M	EURO10 / SF, 693/SH70	180	30	36	4,3-5,5	288.180.36M
350	30	4	72	4,4	TCG	282.072.14M	EURO30SF, 693/SH90	180	30	36	4,3-5,5	288.180.36M
400	30		72	4,4	TCG	282.072.14M	693/SH110	180	30	36	4,3-5,5	288.180.36M
350	30	4	72	4,4	TCG	282.072.14M	SCHELLING FI, FM	200	20	36	4,3-5,5	288.200.36H
400	30		72	4,4	TCG	282.072.16M	FW/AW, AK	200	20	36	4,3-5,5	288.200.36H
450	80	2+4	72	4,8	TCG	282.072.18W2	SCHWEBEDISSSEN S50, S50 CNC					
250	30	2	60	3,2	TCG	281.060.10M	SCHEER FM	140	16	24	3,1-4	Y288.140.24E
350	30	4	72	4,4	TCG	282.072.14M	SCM Z15, Z32, Z45	160	55	36	4,3-5,5	288.160.36Q
400	80	2+4	72	4,4	TCG	282.072.16W2	SELCO WN 200, WNT 200	200	65	36	4,3-5,5	288.200.36J
430	80	2+4	72	4,4	TCG	282.072.17W2	WN 200, WNT 200	300	65	72	4,3-5,5	288.300.72J
450	80	2+4	72	4,8	TCG	282.072.18W2	WN 200, WNT 200	200	65	36	4,3-5,5	288.200.36J
300	30		60	4,4	TCG	282.060.12M	STETON SPLENDIDA	120	30	24	4,3-5,5	Y288.120.24M
400	60	2	72	4,4	TCG	Y282.072.16U	S2000	180	30	36	4,3-5,5	288.180.36M
500	60	2	72	4,8	TCG	282.072.20U	CENTURY	180	30	36	4,7-6,0	288.180.36M

CMT panel sizing saw blades are the perfect tools to cut chipboard and melamine panels.
To use on panel sizing machines.



281
282



CARBIDE GRADE	HARDNESS HRA	93.6
	RUPTURE STRENGTH PS.I.	334,000

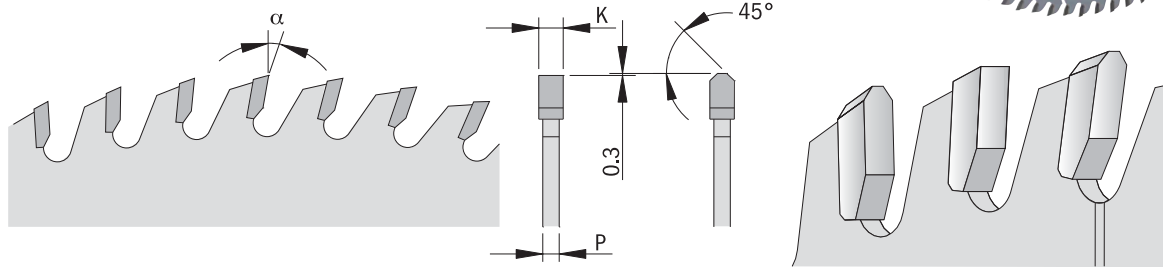
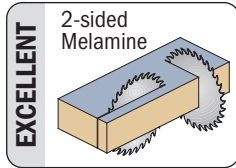

Order No. 1 pc.	Diameter mm	No. of teeth	Bore mm	Pin Hole	Type of grind	Kerf mm	Plate mm	Hook Angle
281.064.09M	220	64	30	2/7/42	TCG	3.2	2.2	10°
281.060.10M	250	60	30	2/10/60+2/7/42	TCG	3.2	2.2	10°
281.080.10M	250	80	30	2/10/60+2/7/42	TCG	3.2	2.2	10°
282.060.12M	300	60	30		TCG	4.4	3.2	16°
281.072.12M	300	72	30	2/10/60+2/7/42	TCG	3.2	2.2	10°
282.060.12X	300	60	75	4/9/100+2/14/110+2/7/110	TCG	4.4	3.2	16°
282.060.12W	300	60	80		TCG	4.4	3.2	16°
282.072.14M	350	72	30	4/9/100	TCG	4.4	3.2	16°
281.096.12M	300	96	30	2/10/60+2/7/42	TCG	3.2	2.2	10°
282.072.14T	350	72	50	3/12.5/80	TCG	4.4	3.2	16°
282.072.14W	350	72	80	4/9/100+2/14/110+2/7/110	TCG	4.4	3.2	16°
282.072.14X	350	72	75	4/15/105	TCG	4.4	3.2	16°
281.108.14M	350	108	30	2/10/60+2/7/42	TCG	3.5	2.5	10°
282.072.15U	380	72	60		TCG	4.8	3.5	16°
282.072.16U	400	72	60	2/11/85	TCG	4.4	3.2	16°
282.072.16M	400	72	30		TCG	4.4	3.2	16°
282.072.16X	400	72	75	4/15/105	TCG	4.4	3.2	16°
282.072.16W	400	72	80	4/9/100+2/14/110+2/7/110	TCG	4.4	3.2	16°
282.072.16W2	400	72	80	2/9/130+4/19/120	TCG	4.4	3.2	16°
282.072.17X	430	72	75	4/15/105	TCG	4.4	3.2	16°
282.072.17W2	430	72	80	2/9/130+4/19/120	TCG	4.4	3.2	16°
282.072.18U	450	72	60		TCG	4.8	3.5	16°
282.072.18W2	450	72	80	2/9/130+4/19/120	TCG	4.8	3.5	16°
282.072.20U	500	72	60	2/11/85	TCG	4.8	3.5	16°
Y282.072.20W	500	72	80	4/9/100+2/14/110+2/7/110	TCG	4.8	3.5	16°
282.072.22A	550	72	100		TCG	5.2	3.5	16°

Pin holes samples for panel sizing saw blades

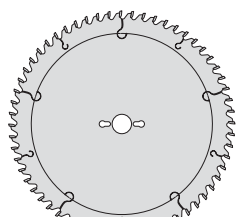

Saw blade with 2+2 pin holes
(2/10/60 + 2/7/42) positioned at 180°

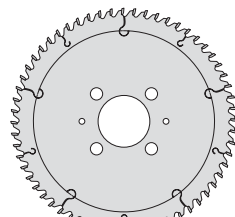

Saw blade with 2+4 pin holes
(2/9/130 + 4/19/120) positioned at 180° and 90°

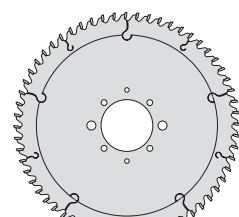

Saw blade with 4+2+2 pin holes
(4/9/100+2/14/110+2/7/110) positioned at 90° and 180°



288



Top-quality scoring blades are essential in many applications, especially with melamine and other laminates. We offer two types: The Conical grind tooth allows you to make different cut widths by increasing or decreasing the cut height.

For use on panel sizing machines.

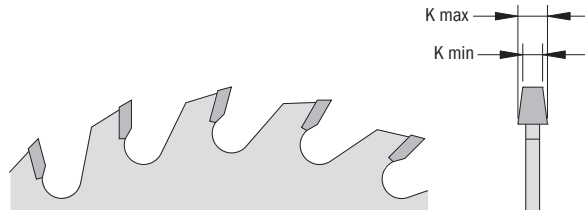

CARBIDE GRADE	HARDNESS	HRA	93.6
	RUPTURE STRENGTH	PS.I.	334,000

Order No. 1 pc.	Diameter mm	No. of teeth	Bore mm	Pin Hole	Type of grind	Kerf mm
Conical						
288.100.20H	100	20	20		Conical	3.1-4.0
288.120.24H	120	24	20		Conical	3.1-4.0
288.120.24K	120	24	22		Conical	3.1-4.0
288.125.24H	125	24	20		Conical	3.1-4.0
288.125.24H2	125	24	20		Conical	4.3-5.5
288.125.24K	125	24	22		Conical	3.1-4.0
288.125.24Q	125	24	45		Conical	4.3-5.5
Y288.140.24E	140	24	16	1/6/33	Conical	3.1-4.0
288.150.36Q	150	36	45		Conical	4.3-5.5
288.160.36Q	160	36	45	3/11/70	Conical	4.3-5.5
288.160.36Q	160	36	55	3/7/66	Conical	4.3-5.5
Y288.160.36Q2	160	36	55	3/7/66	Conical	4.7-6.0
Y288.180.36H	180	36	20		Conical	4.3-5.5
288.180.36M	180	36	30		Conical	4.3-5.5
288.180.36Q	180	36	45		Conical	4.7-6.0
288.180.44T	180	44	50	3/12.5/80	Conical	4.3-5.5
288.180.36Q	180	36	55		Conical	5.0-6.2
288.200.36H	200	36	20		Conical	4.3-5.5
288.200.36Q	200	36	45		Conical	4.7-6.0
288.200.36J	200	36	65	2/9/110	Conical	4.3-5.5
288.215.42T	215	42	50	3/15/80	Conical	4.3-5.5
288.300.48T	300	36	50	3/15/80	Conical	4.3-5.5
288.300.72J	300	72	65	2/9/110	Conical	4.3-5.5

Adjustable Scoring Blades



289



Top-quality scoring blades are essential in many applications, especially with melamine and other laminates. We offer two types: The Flat grind allows you to adjust the cut width by varying the number of shields.

For use on panel sizing machines.

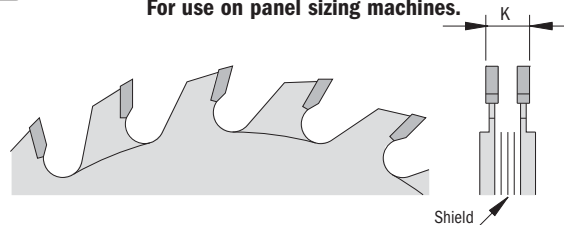

CARBIDE GRADE	HARDNESS	HRA	93.6
	RUPTURE STRENGTH	PS.I.	334,000

Order No. 1 pc.	Diameter mm	No. of teeth	Bore mm	Type of grind	Kerf mm
289.080.20H	80	10+10	20	Flat	2.8-3.6
289.100.20H	100	10+10	20	Flat	2.8-3.6
289.100.20K	100	10+10	22	Flat	2.8-3.6
289.120.24H	120	12+12	20	Flat	2.8-3.6
289.120.24K	120	12+12	22	Flat	2.8-3.6
289.125.24H	125	12+12	20	Flat	2.8-3.6
289.125.24K	125	12+12	22	Flat	2.8-3.6

The 4" CMT Biscuit Joiner blades with trademark orange PTFE Industrial coating make biscuit joining quick and easy. High-grade German steel and 8 micrograin carbide tipped teeth guarantee years of use. Fits Lamello, DeWalt, Porter-Cable, Skil, Bosch, Freud and other popular biscuit joiners models.



240-241

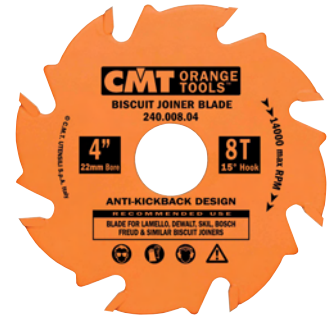

Order No. 1 pc.	Diameter		No. of teeth	Bore	Type of grind	Kerf	Plate
	inches	mm		mm		inches	inches
Fits Lamello, DeWalt, Skil, Bosch, Freud & similar Biscuit Joiners							
240.006.04	4	100	6	22	ATB	0.157	0.122
240.008.04	4	100	8	22	ATB	0.157	0.110
Fits older Porter-Cable & Lamello Biscuit Joiners							
241.008.04	4	100	8	22	ATB	0.157	0.154

Mini-Spot Circular Blade for Lamello

The new CMT Mini-Spot saw blade is ideal to do any type of small repairing on solid wood. Resin, knots and other wood flaws are not a problem anymore. By using original patches, the cut points will be covered up perfectly. The patches will be practically invisible because the wood and patch grain will be in the same direction. For use with Lamello or other machines.



240.004

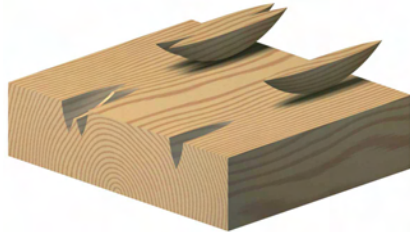

Order No. 1 pc.	Diameter		No. of teeth	Bore	Kerf	Plate	Hook Angle
	inches	mm		mm	inches	inches	
240.004.04	4	100	4	22	0.315	0.236	18°

Reduction Rings for Saw Blades

Order No.	D_Outside diam.	d_Inside diam.	T_Thickness
	inches	mm	inches
299.211.00		30	5/8
299.212.00		30	1
299.213.00	1	25.4	3/4
299.216.00	1	25.4	5/8
299.217.00	5/8	15.87	1/2
299.218.00	5/8	15.87	10mm

299

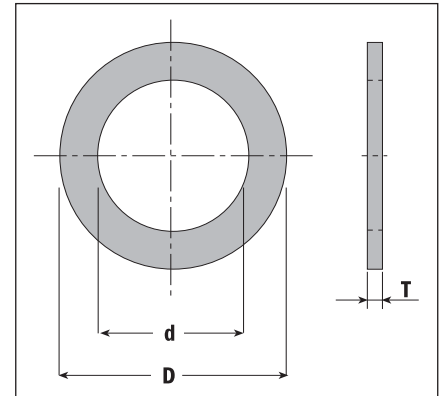

Patented Saw Blade Carry Case

U.S. Patent No. Des. 397,934

03.01



BLACK

ORANGE

Keeping your blades clean and stored properly is the key to longer blade life - so the CMT technical department designed this sturdy, HDPE plastic reusable blade case to hold all your CMT blades. Available in 6 sizes to fit most saw blade diameters.

Order No. black	Order No. orange	Carry Case for saw blade diameters
	03.01.0261	up to 5-3/8"
03.01.0201	03.01.0206	from 5-1/2" to 7-1/4"
03.01.0211	03.01.0209	from 7-3/8" to 8-1/2"
03.01.0202	03.01.0207	from 8-5/8" to 10"
03.01.0212	03.01.0210	from 10-1/8" to 12"
03.01.0203	03.01.0208	from 12-1/8" to 14"

Balance Blade & Sanding Disk & Saw Blade Stabilizer



299.111/112

Before starting a saw project, balance your CMT blade in your table saw with the CMT Balance Blade & Sanding Disk. Mount the Balance Blade & Sanding Disk in your table saw and line it up with a square for accuracy. Remove the balance blade and mount your saw blade for true and precise cuts. Or use the Balance Blade & Sanding Disk as a sander by attaching a self-stick sandpaper disk to the balance blade and installing it in your table saw.

Balance Blade & Sanding Disk

Order No. 1 pcs.	Description	Disk Diameter inches	Disk Diameter mm	Bore inches
299.111.00	Balance blade & Sanding disk	8	203	5/8
299.112.00	Balance blade & Sanding disk	10	250	5/8



299.101/102

The CMT Blade Stabilizer virtually eliminates rim vibration to make cleaner, straighter cuts and extend the life of your CMT saw blade. It also helps to eliminate distracting noise caused by vibration during cutting. NOTE - for use on stationary saws only. Each order includes 2 Stabilizers.

Saw Blade Stabilizer

Order No. 1 pc.	Description	Disk Diameter inches	Disk Diameter mm	Bore inches
299.101.00	Stabilizer (2) for 8" blades	3	75	5/8
299.102.00	Stabilizer (2) for 10" blades	5	125	5/8

Explanation of symbols and abbreviations

T.C.T.
(Tungsten carbide tipped)

Anti-kickback design

Low noise

Polycrystalline Diamond

Plastic carry case for saw blade (BLACK)

Plastic carry case for saw blade (ORANGE)

Cardboard box for saw blades

HRA = Hardness

P.S.I. = Transverse Rupture Strength



Solid Carbide Spiral Bits & Chucks



Collet Chuck HSK 169



Collet Chuck ISO 30 170



Precision Collet "ER32" - "ER40" 173



... 2-Edge Compression Spiral Bits 174



Solid Carbide 1-Edge Spiral Bit 174



Solid Carbide 2-Edge Spiral Bits 175



Solid Carbide 3-Edge Spiral Bit 176



Diamond Compression Bits 177



MDF Door Set 178

183-HSK/ISO For HSK-F63 and ISO30 chucks



Order No.	Description
183-HSK	Universal assembly support for chucks HSK-F63
183-ISO	Universal assembly support for chucks ISO30

CMT now offers a new universal assembly support system for HSK-F63 and ISO 30 chucks. The innovation lies in the special bidirectional roller bearings which clamp the tool holder to the flange. This unique system offers maximum protection to the tool taper and clamps are no longer needed!

The special bidirectional roller bearing, clamps the tool holder to the flange, offering maximum protection to the tool taper.



Cutter Arbor



183.360 ...with HSK tapered shank

Order No.	S_Shank diameter	For machines
183.360.00	HSK-F63	Homag, Eima, IMA from 9/94, Dubus, Weeke, Biesse, SCM, Morbidelli and Masterwood

183.260 ...with ISO 30 tapered shank

Order No.	S_Shank diameter	For machines
183.260.00	ISO 30	Biesse

Other measures available on request.

183.300

Order No. Right-hand rotation	Order No. Left-hand rotation	S_Shank diameter	For machines
183.300.01	183.300.02	HSK-F63	Homag, Eima, IMA from 9/94, Dubus, Weeke, Biesse, SCM, Morbidelli and Masterwood

Spare parts and accessories:

Order No.	Description
991.183.00	C-Spanner 52/55
992.183.01	Clamping nut, M40x1,5 right
992.183.02	Clamping nut, M40x1,5 left
992.183.11	Clamping nut with bearing, M40x1,5 right
992.183.12	Clamping nut with bearing, M40x1,5 left

For precision collets "ER32" Order No. 184.000 please see page 173

183.310

Order No. Right-hand rotation	Order No. Left-hand rotation	S_Shank diameter	For machines
183.310.01	183.310.02	HSK-F63	For Homag, Eima, IMA from 9/94, Dubus, Weeke, Biesse, SCM, Morbidelli and Masterwood machines

Spare parts and accessories:

Order No.	Description
991.283.00	C-Spanner 58/62/65
992.383.01	Clamping nut, M50x1,5 right
992.383.02	Clamping nut, M50x1,5 left
992.383.11	Clamping nut with bearing, M50x1,5 right

For precision collets "ER40" Order No. 184.002 please see page 173





183.200

Order No. Right-hand rotation	Order No. Left-hand rotation	S_Shank diameter	For machines
183.200.01	183.200.02	ISO 30	Biesse

183.210

Order No. Right-hand rotation	Order No. Left-hand rotation	S_Shank diameter	For machines
183.210.01	183.210.02	ISO 30	Biesse with Omlat engine, Bulleri, Busellato, CMS and IMA

183.220

Order No. Right-hand rotation	Order No. Left-hand rotation	S_Shank diameter	For machines
183.220.01	183.220.02	ISO 30	Alberti and Masterwood

Spare parts and accessories:

Order No.	Description
995.200.00	Retaining stud Ø12/8mm for chuck 183.200
995.201.00	Retaining stud Ø13/9mm for chuck 183.210
995.202.00	Retaining stud Ø12.8/9mm for chuck 183.220
991.183.00	C-Spanner 52/55
992.183.01	Clamping nut, M40x1,5 right
992.183.02	Clamping nut, M40x1,5 left
992.183.11	Clamping nut with bearing, M40x1,5 right
992.183.12	Clamping nut with bearing, M40x1,5 left

For precision collets “ER32” Order No. 184.000 please see page 173



183.201

Order No. Right-hand rotation	S_Shank diameter	For machines
183.201.01	ISO 30	Biesse

183.211

Order No. Right-hand rotation	S_Shank diameter	For machines
183.211.01	ISO 30	Biesse machines with Omlat engine and Bulleri, CMS and IMA

183.221

Order No. Right-hand rotation	S_Shank diameter	For machines
183.221.01	ISO 30	Alberti and Masterwood

Spare parts and accessories:

Order No.	Description
995.200.00	Retaining stud Ø12/8mm for chuck 183.201
995.201.00	Retaining stud Ø13/9mm for chuck 183.211
995.202.00	Retaining stud Ø12.8/9mm for chuck 183.221
991.283.00	C-Spanner 58/62/65
992.383.01	Clamping nut, M50x1,5 right
992.383.02	Clamping nut, M50x1,5 left
992.383.11	Clamping nut with bearing, M50x1,5 right

For precision collets “ER40” Order No. 184.002 please see page 173

183.251 with aluminum flange already assembled

Order No. Right-hand rotation	Order No. Left-hand rotation	S_Shank diameter	For machines
183.251.01	183.251.02	ISO 30	Morbidelli and SCM

183.250

Order No. Right-hand rotation	Order No. Left-hand rotation	S_Shank diameter	For machines
183.250.01	183.250.02	ISO 30	Morbidelli and SCM

Spare parts and accessories:

Order No.	Description
995.250.00	Retaining stud Ø8.5mm for chuck 183.250/251
992.501.00	Aluminium flange Ø69.5mm for chuck 183.251
991.183.00	C-Spanner 52/55
992.183.01	Clamping nut, M40x1,5 right
992.183.02	Clamping nut, M40x1,5 left
992.183.11	Clamping nut with bearing, M40x1,5 right
992.183.12	Clamping nut with bearing, M40x1,5 left

For precision collets “ER32” Order No. 184.000 please see page 173

183.255

Order No. Right-hand rotation	S_Shank diameter	For machines
183.255.01	ISO 30	Morbidelli/SCM

Spare parts and accessories:

Order No.	Description
995.250.00	Retaining stud Ø8.5mm for chuck 183.255
991.283.00	C-Spanner 58/62/65
992.283.01	Clamping nut, M48x2 right
185.250.00	Precision collet Ø25mm DIN6388

For precision collets Ø2mm to Ø25mm available on request

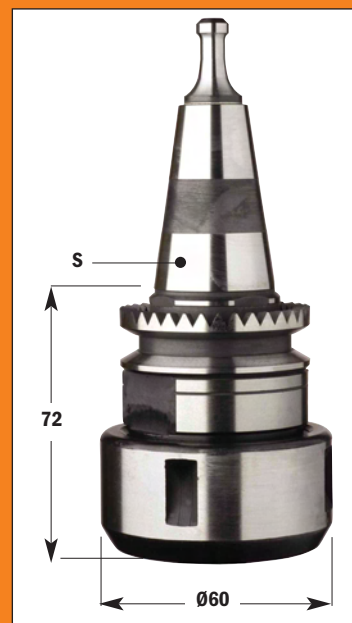
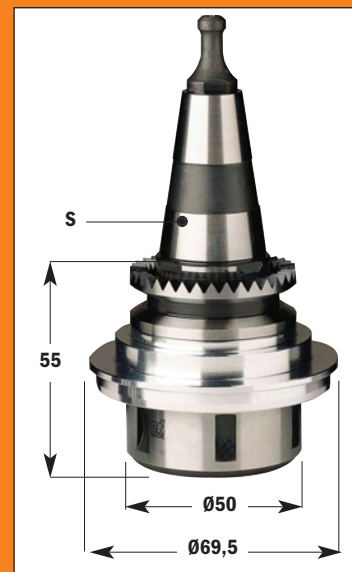

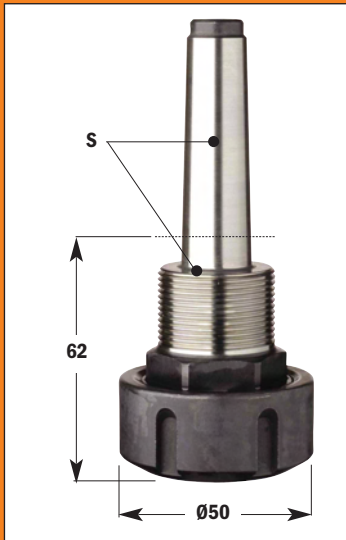

183.000/100

Order No. Right-hand rotation	Order No. Left-hand rotation	S_Shank diameter	For machines
183.000.01	183.000.02	MK2/M30x1.5mm	with MK2 system
183.100.01		MK3/M30x1.5mm	with MK3 system

Spare parts and accessories:

Order No.	Description
991.183.00	C-Spanner 52/55
992.183.01	Clamping nut, M40x1,5 right
992.183.02	Clamping nut, M40x1,5 left
992.183.11	Clamping nut with bearing, M40x1,5 right
992.183.12	Clamping nut with bearing, M40x1,5 left

For precision collets "ER32" Order No. 184.000 please see page 163



993.0 Cap nut for point to point machines

Order No. Right-hand rotation	Order No. Left-hand rotation	Internal Thread	For machines
993.020.01	993.020.02	Ø20x14F1"	with M33x3 threaded spindle nose
993.030.01	993.030.02	M30x1.5	

Collet Chuck Parallel Shank Ø25mm



183.400

Order No. Right-hand rotation	S_Shank diameter	For machines
183.400.01	Ø25x55mm	with PS Leuco System

Spare parts and accessories:

Order No.	Description
995.400.00	Retaining stud for PS Leuco System
991.183.00	C-Spanner 52/55
992.183.01	Clamping nut, M40x1,5 right
992.183.11	Clamping nut with bearing, M40x1,5 right
992.183.12	Clamping nut with bearing, M40x1,5 left

For precision collets "ER32" Order No. 184.000 please see page 163

184.000

Order No.	D ₃ _For shank diameter inches	diameter mm
184.030.00		3
184.040.00		4
184.050.00		5
184.060.00		6
184.065.00	1/4	6.35
184.070.00		7
184.080.00	5/16	8
184.100.00	3/8	10
184.120.00		12
184.130.00	1/2	13
184.140.00		14
184.160.00	5/8	16
184.180.00		18
184.190.00	3/4	19
184.200.00		20

For collet chucks Order No.
183.000/100/200/210/220/250/251/300/400

TECHNICAL DETAILS

- Replaceable collets Std "ER32" (from 3 to 20mm)
- Fits most tapered spindle noses
- Wide clamping tolerance ± 0,7mm

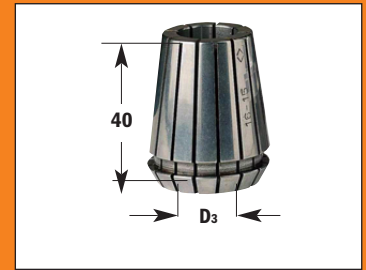

Precision Collet "ER40"

184.002

Order No.	D ₃ _For shank diameter inches	diameter mm
184.042.00		4
184.052.00		5
184.062.00		6
184.072.00		7
184.082.00	5/16	8
184.102.00	3/8	10
184.122.00		12
184.132.00	1/2	13
184.142.00		14
184.162.00	5/8	16
184.182.00		18
184.192.00	3/4	19
184.202.00		20
184.252.00		25

For collet chucks Order No.
183.201/211/221/310

TECHNICAL DETAILS

- Replaceable collets Std "ER40" (from 4 to 25mm)
- Fits most tapered spindle noses
- Wide clamping tolerance ± 0,7mm



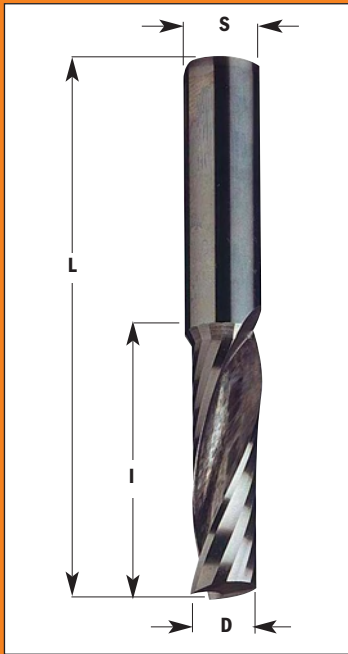

198 Upcut 1-Edge

Order No. Right-hand	D_Cutting diameter		I_Cutting length	L_Overall length	S_Shank diameter
	inches	mm	inches	inches	inches
198.001.11	1/8	3.18	1/2	2	1/8
198.005.11	3/16	4.76	5/8	2	3/16
198.007.11	1/4	6.35	3/4	2	1/4
198.008.11	1/4	6.35	1	2-1/2	1/4
198.504.11	3/8	9.52	1-1/8	3	3/8

TECHNICAL DETAILS:

- Premium quality super-micrograin carbide
- 1 up cut spiral cutting edges (Z1)
- Provides an excellent finish on the lower side of the workpiece
- Upward chip ejection

APPLICATION:

used for cutting, copying, panel sizing and any routing applications in solid wood, or wood composites, plastic materials and laminates. Used a high feed speed on well-clamped workpiece. Can used on machining centres, point to point machines, CNC routers and hand-held routers equipped with chucks or adaptors.

Solid Carbide 2-Edge Compression Spiral Bits

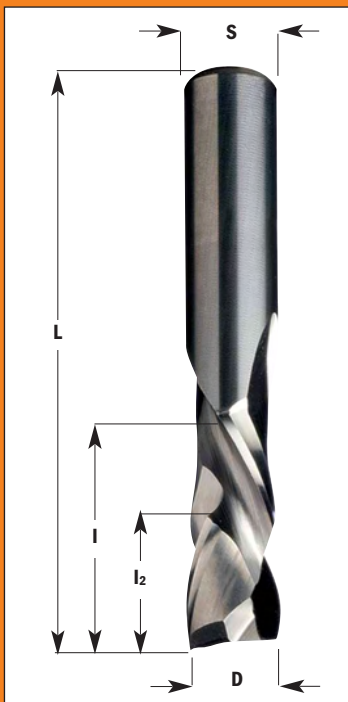

190 Compression Upcut & Downcut 2-Edge

Order No. Right-hand	D_Cutting diameter		I_Cutting length	I ₂ Upcut Cutting length	L_Overall length	S_Shank diameter
	inches	mm	inches	inches	inches	inches
190.504.11	3/8	9.53	1-1/8	7/16	3	3/8
190.505.11	1/2	12.7	1	5/8	3	1/2
190.506.11	1/2	12.7	1-1/8	5/8	3	1/2
190.507.11	1/2	12.7	1-3/8	5/8	3-1/2	1/2
190.508.11	1/2	12.7	1-5/8	5/8	4	1/2

190 Mortise Compression Upcut & Downcut 2-Edge

Order No. Right-hand	D_Cutting diameter		I_Cutting length	I ₂ Upcut Cutting length	L_Overall length	S_Shank diameter
	inches	mm	inches	inches	inches	inches
190.513.11	3/8	9.53	7/8	3/16	3	3/8
190.515.11	1/2	12.7	7/8	13/64	3	1/2
190.517.11	1/2	12.7	1-3/8	13/64	3-1/2	1/2

TECHNICAL DETAILS:

- Premium quality super-micrograin carbide - 2+2 spiral cutting edges (Z2+2)
- Provides excellent finish on both top and bottom side of the workpiece
- The upcut provides an excellent finish on the bottom edge. The downcut provides an excellent finish on the top edge.

APPLICATION: for an excellent edge finish on the top and bottom sides of laminates and double sided melamine. Can also be used with hardwoods and other wood and plastic composites. For fast feed rates on CNC routers, machining centers and point to point machines for ripping, panel sizing, template routing and other routing applications.

191 Upcut 2-Edge

Order No. Right-hand	D_Cutting diameter		I_Cutting length	L_Overall length	S_Shank diameter
	inches	mm	inches	inches	inches
191.001.11	1/8	3.18	1/2	2	1/4
191.003.11	5/32	3.97	1/2	2	1/4
191.005.11	3/16	4.76	3/4	2	1/4
191.007.11	1/4	6.35	3/4	2	1/4
191.008.11	1/4	6.35	1	2-1/2	1/4
191.501.11	5/16	7.94	1	3	1/2
191.503.11	3/8	9.53	1-1/4	3	1/2
191.505.11	1/2	12.7	1-1/4	3	1/2
191.506.11	1/2	12.7	1-1/2	3-1/2	1/2
191.507.11	1/2	12.7	2	4	1/2
191.509.11	5/8	15.88	2-1/8	4-5/16	5/8
191.511.11	3/4	19.05	2-1/8	4-5/16	3/4

NEW 191.008.11-X10 **10 pcs. in masterpack**

TECHNICAL DETAILS:

- Premium quality super-micrograin carbide
- 2 spiral cutting edges (Z2)
- Provides excellent finish on bottom side of the workpiece - Upward chip ejection

APPLICATION:

For an excellent edge finish on the bottom side of laminates and melamines. Can also be used with hardwoods and other wood and plastic composites.

For fast feed rates on CNC routers, machining centers and point to point machines for ripping, panel sizing, template routing and other routing applications.

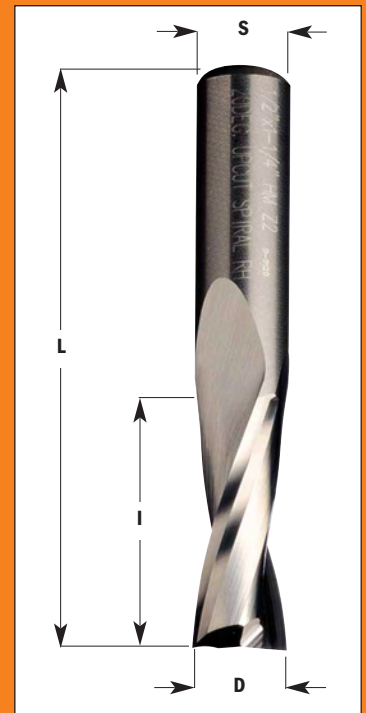

192 Downcut 2-Edge

Order No. 1/4" shank	Order No. 1/2" shank	D_Cutting diameter		I_Cutting length	L_Overall length
		inches	mm	inches	inches
192.001.11		1/8	3.18	1/2	2
192.003.11		5/32	3.97	1/2	2
192.005.11		3/16	4.76	3/4	2
192.007.11		1/4	6.35	3/4	2
192.008.11		1/4	6.35	1	2-1/2
	192.501.11	5/16	7.94	1	3
	192.503.11	3/8	9.53	1-1/4	3
	192.505.11	1/2	12.7	1-1/4	3
	192.506.11	1/2	12.7	1-1/2	3-1/2
	192.507.11	1/2	12.7	2	4

TECHNICAL DETAILS:

- Premium quality super-micrograin carbide
- 2 spiral cutting edges (Z2)
- Provides excellent finish on top side of the workpiece - Downward chip ejection

APPLICATION:

For an excellent edge finish on the bottom side of laminates and melamines. Can also be used with hardwoods and other wood and plastic composites.

For fast feed rates on CNC routers, machining centers and point to point machines for ripping, panel sizing, template routing and other routing applications.

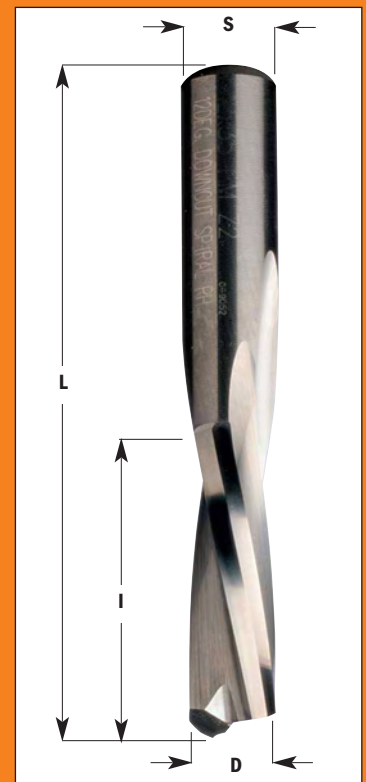

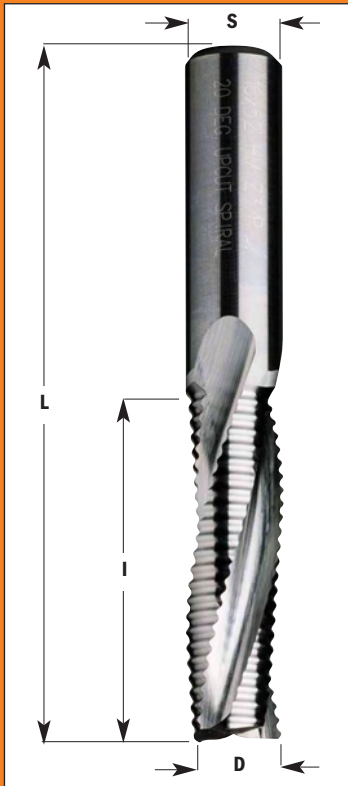

195 Upcut 3-Edge Chipbreaker

Order No. Right-hand	D_Cutting diameter inches mm	I_Cutting length inches	L_Overall length inches	S_Shank diameter inches
195.506.11	1/2 12.7	1-1/2	3-1/2	1/2
195.509.11	5/8 15.88	2-1/8	4-5/16	5/8
195.511.11	3/4 19.05	2-1/8	4-5/16	3/4

TECHNICAL DETAILS:

- Premium quality super-micrograin carbide
- 3 spiral cutting edges [Z3]
- Tooth depth max 0.3mm
- For fast routing on CNC equipment when edge finish is less important
- Upward chip ejection.

APPLICATION:

For fast removal of material in panel sizing operations.

For fast feed rates on CNC routers, machining centers and point to point machines for ripping, panel sizing, template routing and other routing applications.

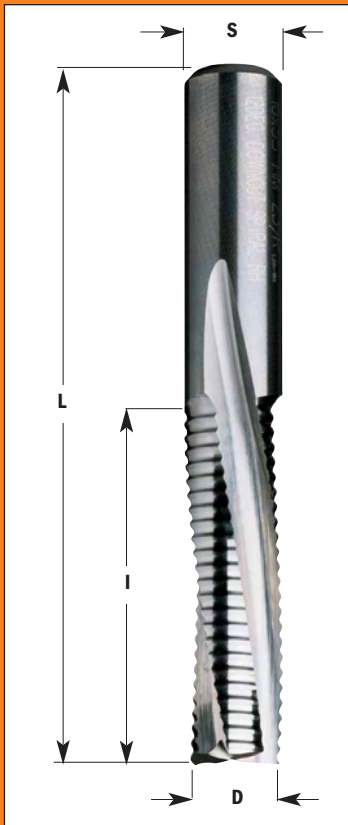

196 Downcut 3-Edge Chipbreaker

Order No. Right-hand	D_Cutting diameter inches mm	I_Cutting length inches	L_Overall length inches	S_Shank diameter inches
196.506.11	1/2 12.7	1-1/2	3-1/2	1/2
196.509.11	5/8 15.88	2-1/8	4-5/16	5/8
196.511.11	3/4 19.05	2-1/8	4-5/16	3/4

TECHNICAL DETAILS:

- Premium quality super-micrograin carbide
- 3 spiral cutting edges (Z3)
- Tooth depth max 0.3mm
- For fast routing on CNC equipment when edge finish is less important
- Downward chip ejection.

APPLICATION:

For fast removal of material in panel sizing operations.

For fast feed rates on CNC routers, machining centers and point to point machines for ripping, panel sizing, template routing and other routing applications.



140 DIAMOND

Order No. Right-hand	D_Cutting diameter		I_Cutting length	L_Overall length	S_Shank diameter	Z_No. of teeth
	inches	mm	inches	inches	inches	
140.127.61	1/2	12.7	1-1/16	2-3/4	1/2	1+1 (4DP+1HW)
140.128.61	1/2	12.7	1-13/32	3-1/8	1/2	1+1 (4DP+1HW)
140.158.61	5/8	15.87	1-1/16	3	5/8	1+1 (3DP+1HW)
140.159.61	5/8	15.87	1-49/64	4	5/8	1+1 (5DP+1HW)
140.190.61	3/4	19.05	1-1/16	4	3/4	1+1 (3DP+1HW)
140.192.61	3/4	19.05	1-49/64	4	3/4	1+1 (5DP+1HW)

TECHNICAL DETAILS:

- Super strength steel
- DP (Diamond) cutting edge
- HW (Carbide tipped) plunging tip
- Resharpenable cutter

APPLICATION:

for routing and sizing ultra-hard and abrasive material.
Can be used on machining centres, CNC routers equipped with chucks or adaptors.



Straight router cutters with knives

653 HW Z1+1

Shank Ø1/2"

Order No. Right-hand	D_Cutting diameter		I_Cutting length inches	L_Overall length inches	Spare knives	
	inches	mm			side	top
653.158.11	5/8	15,8	28,3	91,5	790.283.12	790.075.00
653.159.11	5/8	15,8	48,3	111,5	790.483.12	790.075.00

Spare parts and accessories:

Order No.	Description
790.075.00	Knives 7,5 x 12 x 1,5mm
790.096.00	Knives 9,6 x 12 x 1,5mm
790.283.12	Knives 28,3 x 12 x 1,5mm
790.483.12	Knives 48,3 x 12 x 1,5mm
990.072.00	Torx screw M3,5x3,5mm
990.074.00	Torx screw M4x3,5mm
990.075.00	Torx screw M4x6mm
991.061.00	Torx key T15

TECHNICAL DETAILS:

- Super Strength steel
- 2 cutting edges (Z1+1)

APPLICATION: straight router bit with one replaceable plunging knife and one side knife fixed by special Torx screws. The body is precise balanced. For finishing and routing, plunge cutting and grooving in boards materials (laminated chipboards, MDF) and hard wood.
For use on CNC machining centers.

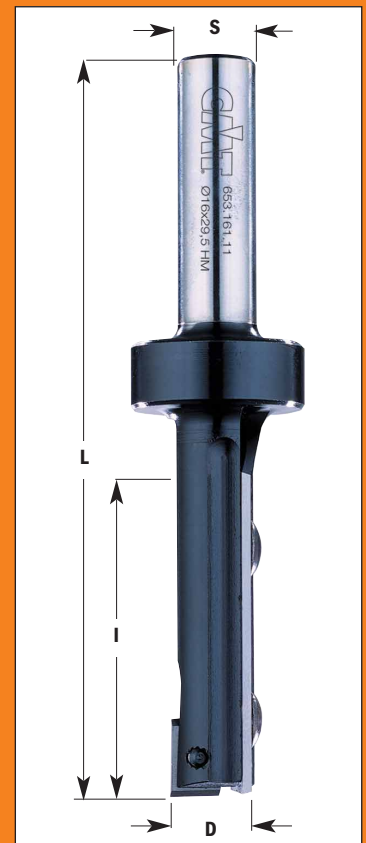

Complete set for MDF Door

new

CMT ORANGE TOOLS™

615.004.01

CARBIDE TIPPED



Open some new doors with CMT. Our 4-piece set includes the most popular profile to make MDF panel doors for kitchens and bathrooms. Each bit is made from bar stock steel and the highest quality tungsten carbide knives. The bodies support 5 different profile knives allowing enormous possibilities for easy and economical construction. The highest quality materials, superior balancing tolerances and precision sharpening, allows for the smoothest possible finish from your CNC machine.



- Spare parts:**
- 991.061.00 Torx key T15
 - 990.073.00 Torx screw M3,5x5
 - 990.075.00 Torx screw M4x6
 - 990.077.00 Torx screw M3,5x7

Order No.	Set contains
20mm shank 615.004.01	Complete set for MDF Door (Profile no. 1)

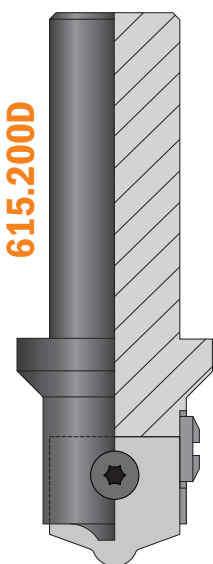
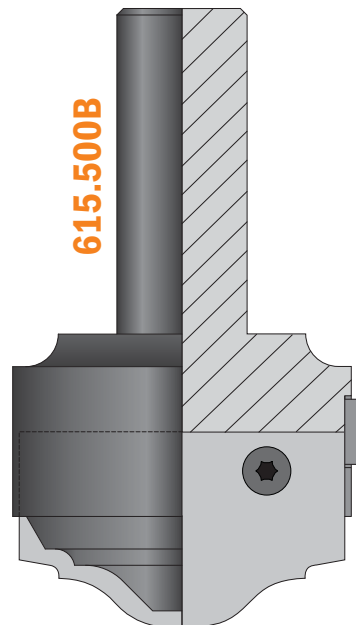
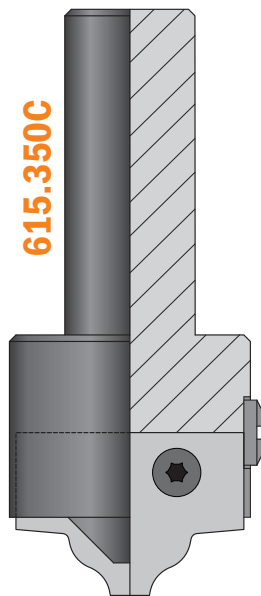
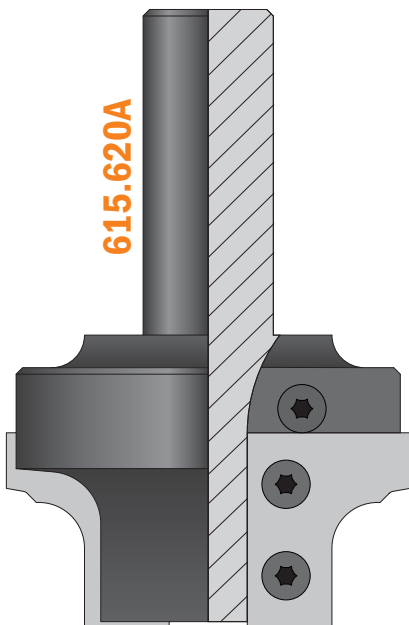
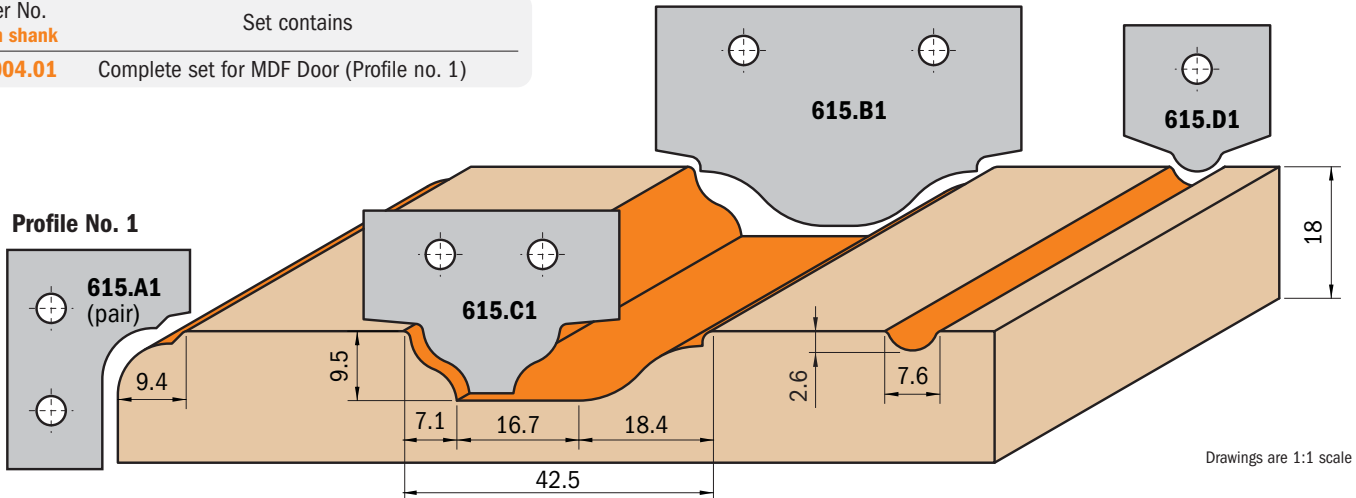

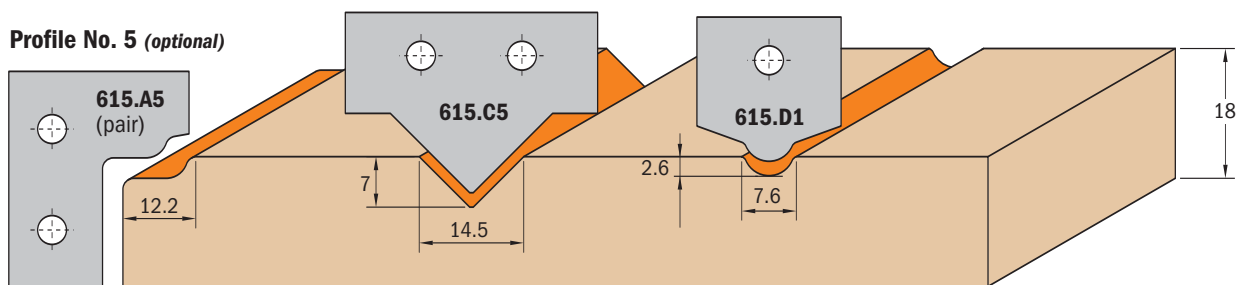
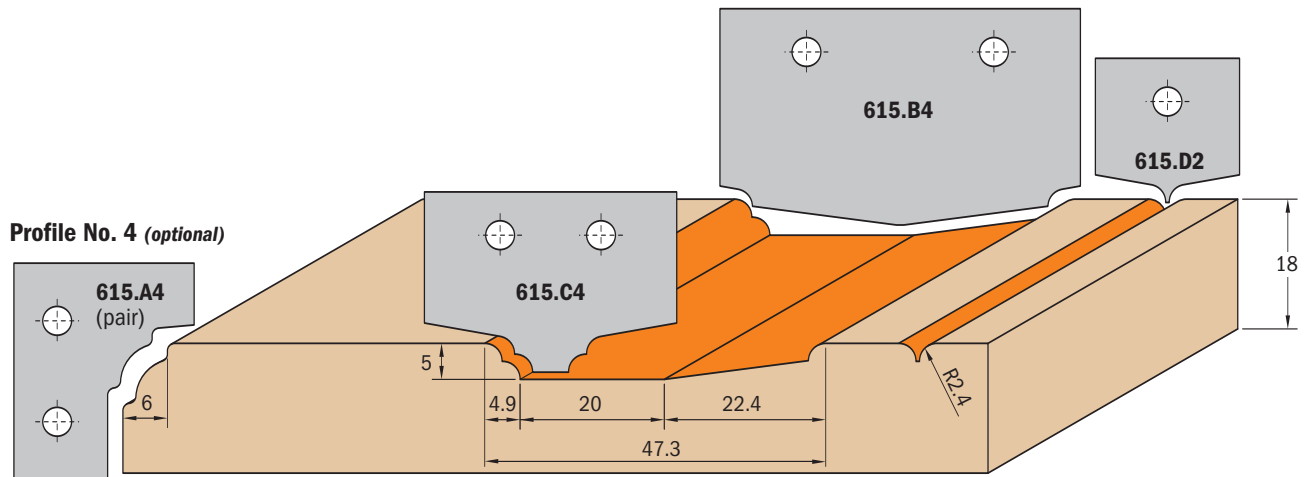
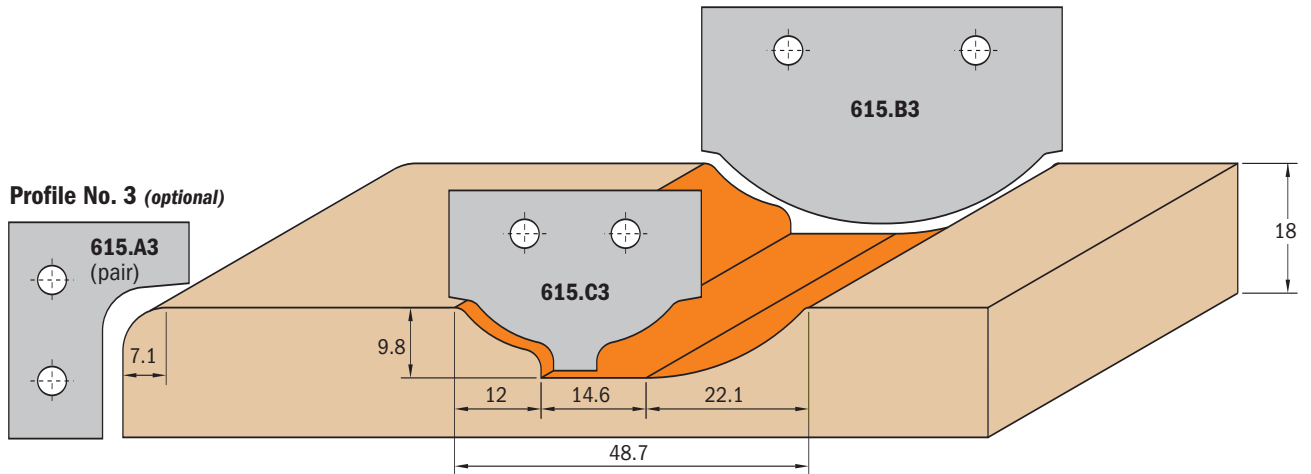
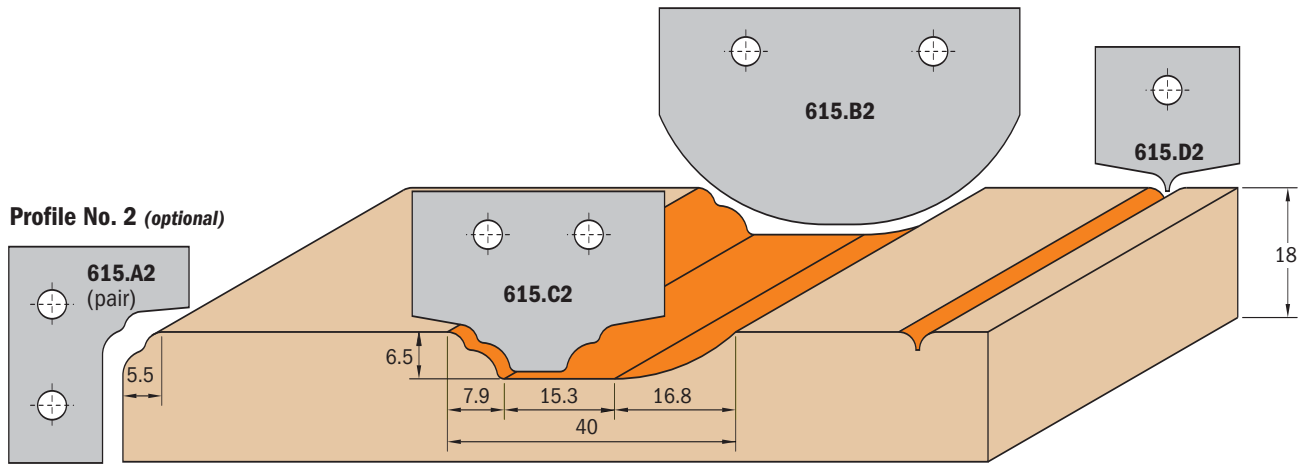

V-Groove - folding - signmaking CNC router cutters new **CMT ORANGE TOOLS™**

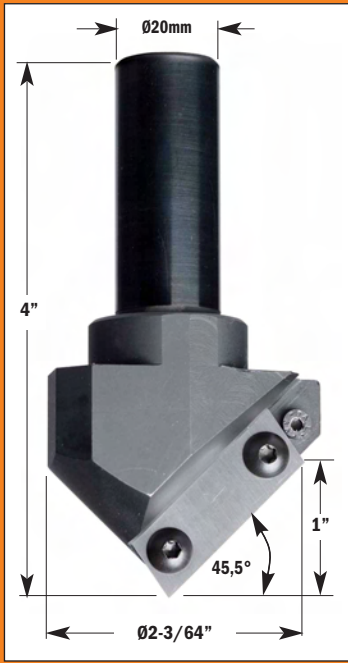

663.101.11 HW Z1

Shank Ø20mm

Order No. Right-hand	D_Cutting diameter		I_Cutting length		L_Overall length
	inches	mm	inches	mm	inches
663.101.11	2-3/64	52	1		4

Spare parts and accessories:

Order No.	Description
790.360.01	Knives 36x12x1,5mm
990.077.00	Screw Torx M3,5x7
991.061.00	Torx key T15

TECHNICAL DETAILS:

- Super Strength steel
- 1 cutting edges (Z1)

APPLICATION: this innovative CNC router bit offer you endless range of possibilities for V-groove, miter folds, signmaking, lettering and chamfer edges.

The tool mount a high grade of HWM reversible knife ideal for general purpose, chipboard and plywood but an higher quality is available for laminated and MDF material.

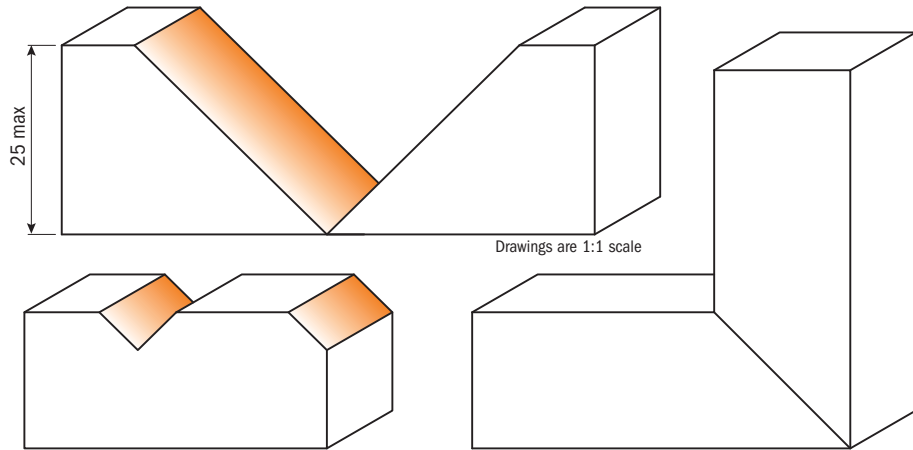

Spoilboard surfacing router cutters new

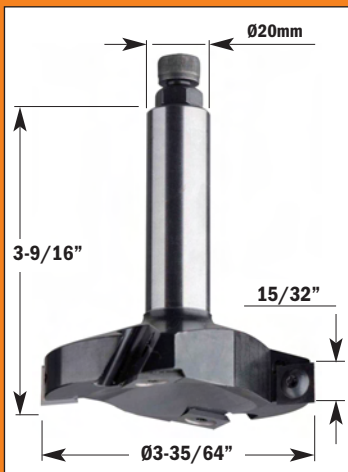

663.001.11 HW Z2+2

Shank Ø20mm

Order No. Right-hand	D_Cutting diameter		I_Cutting length		L_Overall length
	inches	mm	inches	mm	inches
663.001.11	3-35/64"	80	15/32	12	3-9/16

Spare parts and accessories:

Order No.	Description
790.120.00	Knives 12x12x1,5mm
990.075.00	Screw Torx T15 M4x6
991.061.00	Torx key T15
790.140.00	Knives 14x14x2mm
990.083.00	Screw Torx T20 M6x9
991.072.00	Torx key T20

TECHNICAL DETAILS:

- Super Strength steel
- 2 cutting edges (Z2)
- 2 scores knives (V2)

APPLICATION: new router bit for CNC router ideal for fast removal of material over a large surface area leaving an improved finish at the bottom of the cut. Used on soft and hard woods, particle board and MDF . The router bit utilizes 4-sided HWM inserts.

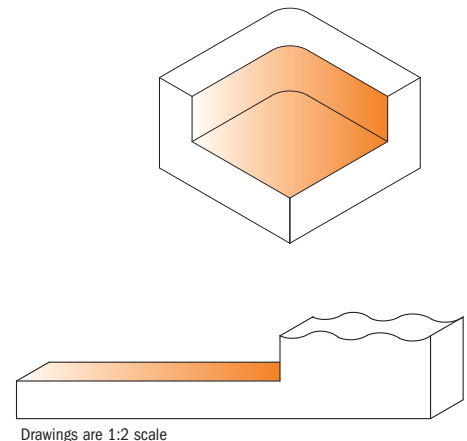

Cost effective solution compared to brazed router bits and solid carbide spiral bits.



Dowel Drills



X-Treme Solid Carbide Dowel Drills 184



X-Treme Dowel Drills 185



2-Flute Dowel Drill 186



Solid Carbide Twist Drills 191



4-Flute Dowel Drills for Through Holes 193



Countersinks for Dowel Drills 195



Dowel Drills with Threaded Shank 189



Diamond Hinge Boring Bits 196



Adaptors 197

X-TREME BORING BITS

SETTING A NEW STANDARD FOR PERFORMANCE AND VALUE

NEW DOWN CUT ROUND SHARPENING

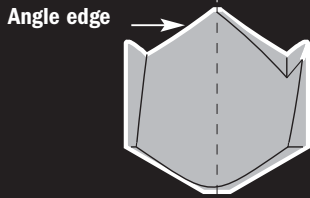

EXTRA-FINE MICROGRAIN CARBIDE

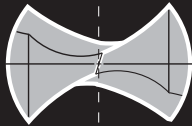

Reduced boring surface enabling
faster feed speed

STANDARD SHARPENING

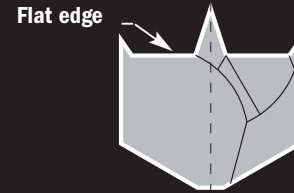

STANDARD CARBIDE

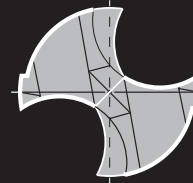

Standard boring surface

Finest Industrial Quality Micrograin Carbide

CMT puts the finest quality at the cutting edge. Produced by Luxembourg's Cerametal, CMT's carbide tips are selected from carbide grades which hold an edge longer and improve durability and impact resistance.

PT.FE. Coating

Our PTFE coating provides a non-stick surface that prevents residue accumulation on the bit. Baked on at 420° C, this unique, industrial strength material is specifically designed to meet the requirements of woodworking tools.

High-Strength Steel Body

The shanks and bodies of all our bits are machined from solid bar stock steel made by Von Moos Steel in Switzerland. The primary mechanical properties are:

- superior strength
- high level uniformity
- minimal distortion
- exceptional resistance to fatigue and abrasion



Micrograin Carbide Sharpening

The sharpening on the carbide cutting edge provides a $0.4\mu/\text{mm}$ micrograin finish. This is done on automated CNC machines that are equipped with as many as 6 axes for maximum accuracy.

Special metal shock resistant brazing

Micrograin carbide tips are applied with a special brazing compound. This allows a higher brazing temperature than other methods, and guarantees a solid bond of every tip on every bit.

Steel shank grinding

CMT grinds the steel shank to a micrograin finish of $0.8\mu/\text{mm}$. The smooth finish on the shank determines how well the drill fits into your machine. A rough grind results in a poor grip by the chuck and wobbly rotation.

314.21/22 SOLID CARBIDE

Order No. Right-hand	Order No. Left-hand	D_Cutting diameter		I_Cutting length	L_Overall length	S_Shank diam.
		inches	mm	mm	mm	mm
314.040.21	314.040.22	5/32	4	40	70	10x20
314.050.21	314.050.22		5	40	70	10x20
314.060.21	314.060.22		6	40	70	10x20
314.080.21	314.080.22	5/16	8	40	70	10x20

new
new

spare parts: 990.008.00 Screw M5x8mm

For panel with a 20-25mm maximum thickness

TECHNICAL DETAILS:

- Premium quality super-strength steel
- S.T.C. spiral portion with center point - 2 precision ground cutting edges (Z2) - 2 spiral flutes
- Parallel shank with driving flat and adjustable screw length.

APPLICATION: used on boring machines alone and dowel drilling devices. Use for drilling through holes in solid wood, wood composites, plastic and laminated materials.

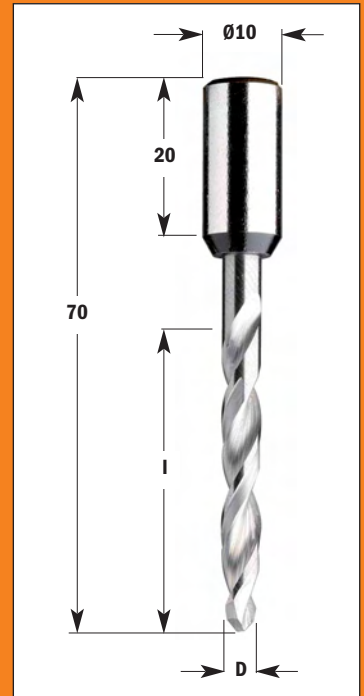

313.41/42 CARBIDE TIPPED

Order No. Right-hand	Order No. Left-hand	D_Cutting diameter	I_Cutting length	L_Overall length	S_Shank diam.
		mm	mm	mm	mm
313.050.41	313.050.42	5	27	57.5	10x26
313.080.41	313.080.42	8	27	57.5	10x26

spare parts: 990.003.00 Screw M5x10mm

For panel with a 20mm maximum thickness

314.41/42 CARBIDE TIPPED

Order No. Right-hand	Order No. Left-hand	D_Cutting diameter	I_Cutting length	L_Overall length	S_Shank diam.
		mm	mm	mm	mm
314.050.41	314.050.42	5	35	70	10x26
314.080.41	314.080.42	8	35	70	10x26

spare parts: 990.003.00 Screw M5x10mm

For panel with a 30mm maximum thickness

TECHNICAL DETAILS:

- Premium quality super-strength steel
- Spiral portion coated with orange or black P.T.F.E.
- Extra-fine micrograin carbide spiral portion with center point
- 2 precision ground cutting edges (Z2)
- 2 spiral flutes
- Parallel shank with driving flat and adjustable screw length.

APPLICATION: used on boring machines and dowel drilling devices. Use for drilling through holes in solid wood, wood composites, plastic and laminated materials.

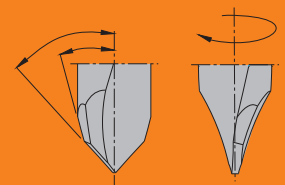
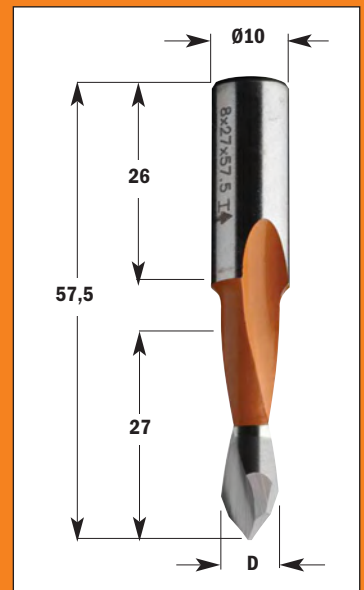

2 precision ground cutting edges

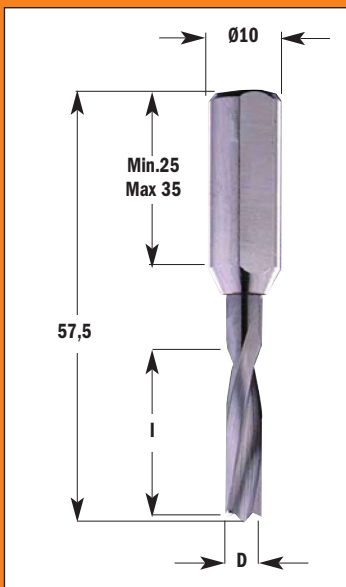

310.21/22 SOLID CARBIDE

new

Order No. Right-hand	Order No. Left-hand	D_Cutting diameter inches	D_Cutting diameter mm	I_Cutting length mm	L_Overall length mm	S_Shank diam. mm
310.530.21	310.530.22		3	9	57.5	10x35
310.030.21	310.030.22		3	18	57.5	10x25
310.040.21	310.040.22		4	20	57.5	10x25
310.050.21	310.050.22		5	22	57.5	10x25
310.060.21	310.060.22		6	22	57.5	10x25
310.064.21	310.064.22	1/4	6.35	22	57.5	10x25

spare parts: 990.003.00 Screw M5x10mm

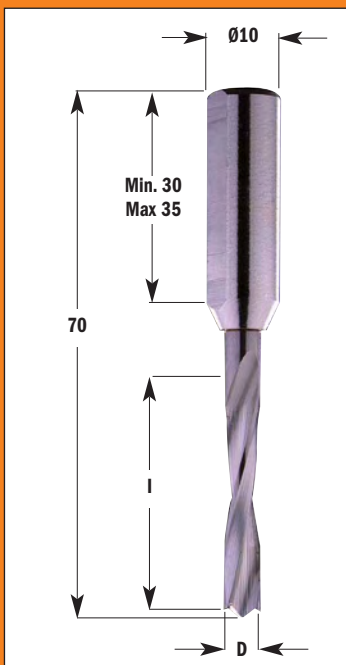

311.21/22 SOLID CARBIDE

Order No. Right-hand	Order No. Left-hand	D_Cutting diameter inches	D_Cutting diameter mm	I_Cutting length mm	L_Overall length mm	S_Shank diam. mm
311.030.21	311.030.22		3	18	70	10x35
311.040.21	311.040.22		4	27	70	10x30
311.050.21	311.050.22		5	30	70	10x30
311.060.21	311.060.22		6	30	70	10x30
311.064.21	311.064.22	1/4	6.35	30	70	10x30

spare parts: 990.003.00 Screw M5x10mm

TECHNICAL DETAILS:

- Premium quality super-strength steel
- S.T.C. spiral portion with center point - 2 cutting edges (Z2) - 2 spiral flutes
- 2 curved, negatively ground spurs (V2) - Parallel shank with driving flat and adjustable screw length.

APPLICATION: used on boring machines alone or with chucks for drilling blind holes in solid wood, wood composites, plastic and laminated materials.

Perfect for all materials and long lasting performance

CMT announces the new series of solid carbide boring bits, now available from their extensive industrial line. These bits are entirely made of premium quality super micrograin carbide from Ceratizit in Luxembourg. The entire series offers several design features:

- The unique tip has curved, negatively ground spurs to produce exceptionally clean bores with no rough edges. Center point balanced.
- The cylindrical head is bigger than traditional tips and is extremely resistant to prolonged use. Lasts longer between sharpenings.
- The plunge edge runs all the way to the center of the bit to reduce drilling resistance and increase production speed.
- The solid carbide construction guarantees an almost infinite number of sharpenings, and because it is a solid unit of carbide, it offers an extra safety feature.
- Ideal for hard woods and difficult composites such as particle board, MDF and veneer.
- Excellent performance on high-speed boring units and CNC routers.

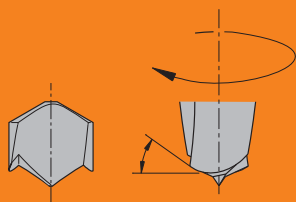

Down cut round engraver

310.41/42 CARBIDE TIPPED

Order No. Right-hand	Order No. Left-hand	D_Cutting diameter mm	I_Cutting length mm	L_Overall length mm	S_Shank diam. mm
310.050.41	310.050.42	5	27	57.5	10x27
310.060.41	310.060.42	6	27	57.5	10x27
310.070.41	310.070.42	7	27	57.5	10x27
310.080.41	310.080.42	8	27	57.5	10x27
310.090.41	310.090.42	9	27	57.5	10x27
310.100.41	310.100.42	10	27	57.5	10x27

spare parts: 990.003.00 Screw M5x10mm

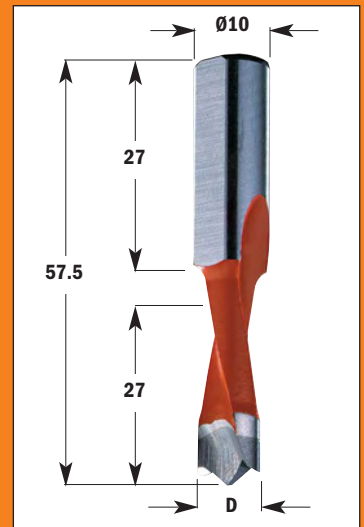

311.41/42 CARBIDE TIPPED

Order No. Right-hand	Order No. Left-hand	D_Cutting diameter mm	I_Cutting length mm	L_Overall length mm	S_Shank diam. mm
311.050.41	311.050.42	5	35	70	10x30
311.060.41	311.060.42	6	35	70	10x30
311.070.41	311.070.42	7	35	70	10x30
311.080.41	311.080.42	8	35	70	10x30
311.090.41	311.090.42	9	35	70	10x30
311.100.41	311.100.42	10	35	70	10x30

spare parts: 990.003.00 Screw M5x10mm

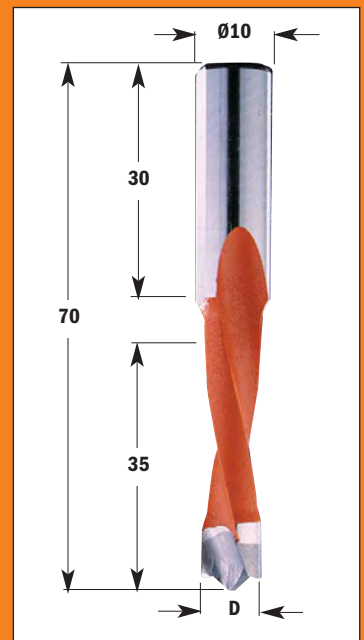

TECHNICAL DETAILS:

- Premium quality super-strength steel
- Spiral portion coated with orange or black P.T.F.E.
- Extra-fine micrograin carbide spiral portion with center point - 2 cutting edges (Z2) - 2 spiral flutes
- 2 curved, negatively ground spurs (V2) - Parallel shank with driving flat and adjustable screw length.

APPLICATION: used on boring machines alone or with chucks for drilling blind holes in solid wood, wood composites, plastic and laminated materials.

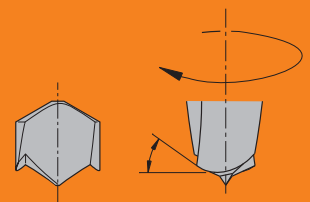

Down cut round engraver

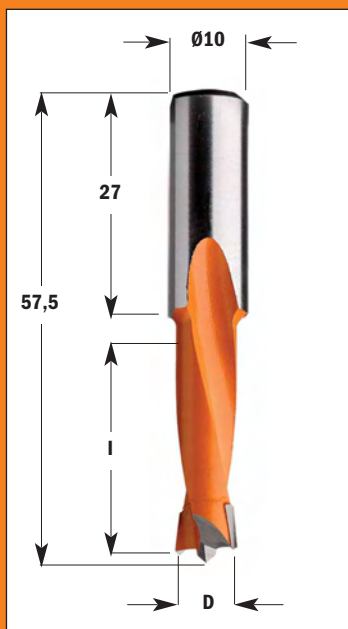

310 CARBIDE TIPPED

Order No. Right-hand	Order No. Left-hand	D_Cutting diameter inches	D_Cutting diameter mm	I_Cutting length mm	L_Overall length mm	S_Shank diam. mm
310.040.11	310.040.12	5/32	4	18	57.5	10x27
310.045.11	310.045.12		4.5	22	57.5	10x27
310.047.11	310.047.12	3/16	4.76	27	57.5	10x27
310.050.11	310.050.12		5	27	57.5	10x27
310.051.11	310.051.12		5.1	27	57.5	10x27
310.052.11	310.052.12		5.2	27	57.5	10x27
310.055.11	310.055.12	7/32	5.55	27	57.5	10x27
310.060.11	310.060.12		6	27	57.5	10x27
310.064.11	310.064.12	1/4	6.35	27	57.5	10x27
310.065.11	310.065.12		6.5	27	57.5	10x27
310.070.11	310.070.12		7	27	57.5	10x27
310.080.11	310.080.12		8	27	57.5	10x27
310.082.11	310.082.12		8.2	27	57.5	10x27
310.090.11	310.090.12		9	27	57.5	10x27
310.095.11	310.095.12	3/8	9.52	27	57.5	10x27
310.100.11	310.100.12		10	27	57.5	10x27
310.110.11	310.110.12		11	27	57.5	10x27
310.120.11	310.120.12		12	27	57.5	10x27
310.127.11	310.127.12	1/2	12.7	27	57.5	10x27
310.130.11	310.130.12		13	27	57.5	10x27
310.140.11	310.140.12		14	27	57.5	10x27
310.150.11	310.150.12		15	27	57.5	10x27
310.160.11	310.160.12		16	27	57.5	10x27

310.050.11-X50 310.050.12-X50 50 pcs. in Masterpack

spare parts: 990.003.00 Screw M5x10mm

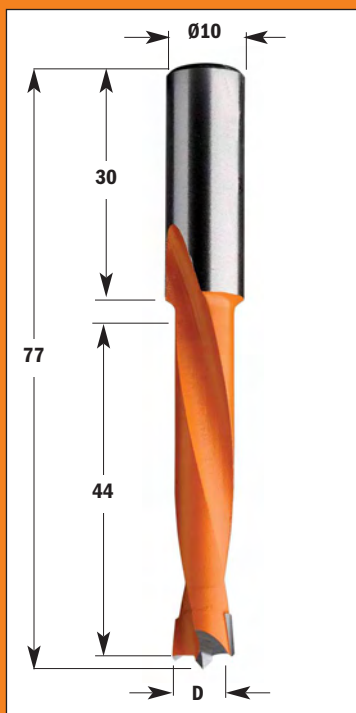

362 CARBIDE TIPPED

Order No. Right-hand	Order No. Left-hand	D_Cutting diameter mm	I_Cutting length mm	L_Overall length mm	S_Shank diam. mm
362.050.11	362.050.12	5	44	77	10x30
362.060.11	362.060.12	6	44	77	10x30
362.070.11	362.070.12	7	44	77	10x30
362.080.11	362.080.12	8	44	77	10x30
362.100.11	362.100.12	10	44	77	10x30
362.120.11	362.120.12	12	44	77	10x30

spare parts: 990.003.00 Screw M5x10mm

TECHNICAL DETAILS:

- Super-strength steel - Spiral portion coated with orange or black P.T.F.E.
- T.C.T. head with precision balanced center point - 2 precision ground T.C.T. cutting edges (Z2) - 2 spiral flutes
- 2 negatively ground spurs (V2) - Parallel shank with driving flat and adjustable screw.

APPLICATION: used on boring machines equipped with adaptors or chucks. Used to drill blind holes in solid wood, wood composites, plastic and laminated materials.

311 CARBIDE TIPPED

Order No. Right-hand	Order No. Left-hand	D_Cutting diameter inches	D_Cutting diameter mm	I_Cutting length mm	L_Overall length mm	S_Shank diam. mm
311.040.11	311.040.12	5/32	4	26	70	10x30
311.045.11	311.045.12		4.5	35	70	10x30
311.047.11	311.047.12	3/16	4.76	35	70	10x30
311.050.11	311.050.12		5	35	70	10x30
311.051.11	311.051.12		5.1	35	70	10x30
311.052.11	311.052.12		5.2	35	70	10x30
311.055.11	311.055.12	7/32	5.55	35	70	10x30
311.060.11	311.060.12		6	35	70	10x30
311.064.11	311.064.12	1/4	6.35	35	70	10x30
311.065.11	311.065.12		6.5	35	70	10x30
311.070.11	311.070.12		7	35	70	10x30
311.080.11	311.080.12		8	35	70	10x30
311.082.11	311.082.12		8.2	35	70	10x30
311.090.11	311.090.12		9	35	70	10x30
311.095.11	311.095.12	3/8	9.52	35	70	10x30
311.100.11	311.100.12		10	35	70	10x30
311.110.11	311.110.12		11	35	70	10x30
311.111.11	311.111.12	7/16	11.1	35	70	10x30
311.120.11	311.120.12		12	35	70	10x30
311.127.11	311.127.12	1/2	12.7	35	70	10x30
311.130.11	311.130.12		13	35	70	10x30
311.140.11	311.140.12		14	35	70	10x30
311.150.11	311.150.12		15	35	70	10x30
311.160.11	311.160.12		16	35	70	10x30

spare parts: 990.003.00 Screw M5x10mm

TECHNICAL DETAILS:

- Super-strength steel - Spiral portion coated with orange or black P.T.F.E.
- T.C.T. head with precision balanced center point - 2 precision ground T.C.T. cutting edges (Z2) - 2 spiral flutes
- 2 negatively ground spurs (V2) - Parallel shank with driving flat and adjustable screw.

APPLICATION: used on boring machines equipped with adaptors or chucks. Used to drill blind holes in solid wood, wood composites, plastic and laminated materials.

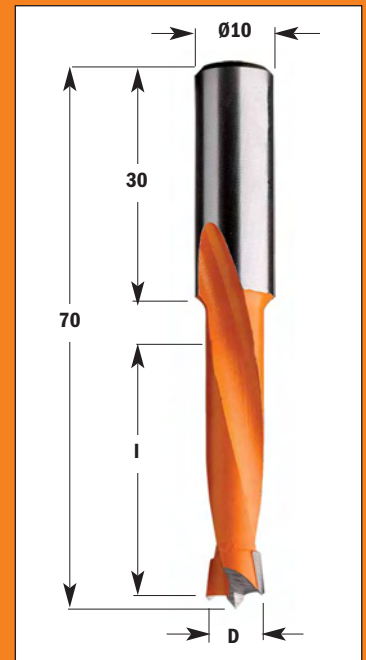

2 Flute Dowel Drills with Countersink

376-377 CARBIDE TIPPED

Order No. Right-hand	Order No. Left-hand	D_Cutting diameter mm	I_Cutting length mm	L_Overall length mm	S_Shank diam. mm
376.080.11	376.080.12	8	12	57.5	10
376.081.11	376.081.12	8	15	57.5	10
376.082.11	376.082.12	8	20	57.5	10
376.100.11	376.100.12	10	12	57.5	10
376.101.11	376.101.12	10	15	57.5	10
376.102.11	376.102.12	10	20	57.5	10
377.080.11	377.080.12	8	12	70	10
377.081.11	377.081.12	8	15	70	10
377.082.11	377.082.12	8	20	70	10
377.100.11	377.100.12	10	12	70	10
377.101.11	377.101.12	10	15	70	10
377.102.11	377.102.12	10	20	70	10

spare parts: 990.003.00 Screw M5x10mm

TECHNICAL DETAILS:

- Super-strength steel - Spiral portion coated with orange or black P.T.F.E.
- T.C.T. head with precision balanced center point - 2+2 precision ground T.C.T. cutting edges (Z2+2)
- 2 spiral flutes - 2 negatively ground spurs (V2) - Parallel shank with driving flat and adjustable screw.

APPLICATION: used for drilling and countersinking in solid wood, wood composites, plastic and laminated materials. Suitable for high performance speed on boring machines equipped with adaptors or chucks.

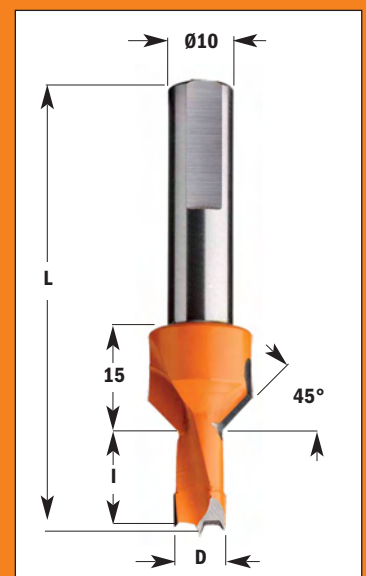

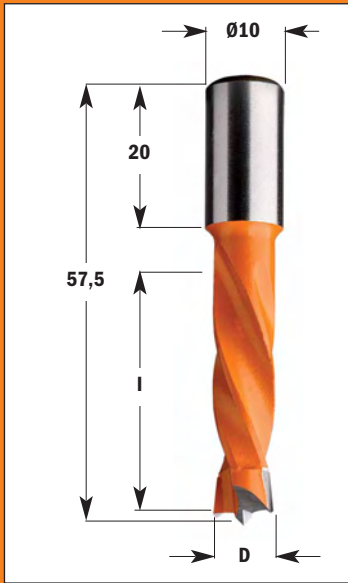

308 CARBIDE TIPPED

Order No. Right-hand	Order No. Left-hand	D_Cutting diameter		I_Cutting length	L_Overall length	S_Shank diam.
		inches	mm	mm	mm	mm
308.040.11	308.040.12	5/32	4	26	57.5	10x20
308.050.11	308.050.12		5	30	57.5	10x20
308.060.11	308.060.12		6	30	57.5	10x20
308.064.11	308.064.12	1/4	6.35	30	57.5	10x20
308.070.11	308.070.12		7	30	57.5	10x20
308.080.11	308.080.12		8	30	57.5	10x20
308.090.11	308.090.12		9	30	57.5	10x20
308.095.11	308.095.12	3/8	9.52	30	57.5	10x20
308.100.11	308.100.12		10	30	57.5	10x20
308.110.11	308.110.12		11	30	57.5	10x20
308.120.11	308.120.12		12	30	57.5	10x20
308.127.11	308.127.12	1/2	12.7	30	57.5	10x20
308.130.11	308.130.12		13	30	57.5	10x20
308.140.11	308.140.12		14	30	57.5	10x20
308.150.11	308.150.12		15	30	57.5	10x20
308.160.11	308.160.12		16	30	57.5	10x20

spare parts: 990.003.00 Screw M5x10mm

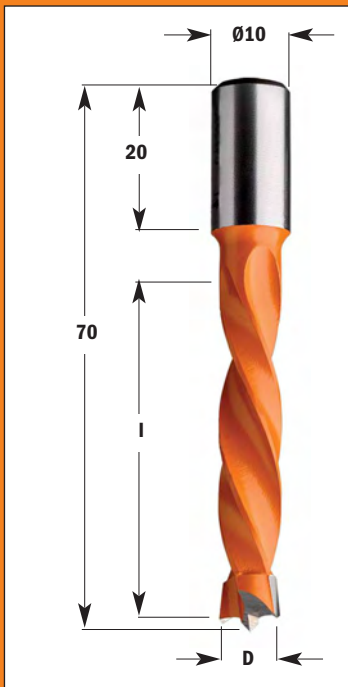

309 CARBIDE TIPPED

Order No. Right-hand	Order No. Left-hand	D_Cutting diameter		I_Cutting length	L_Overall length	S_Shank diam.
		inches	mm	mm	mm	mm
309.040.11	309.040.12	5/32	4	30	70	10x20
309.050.11	309.050.12		5	43	70	10x20
309.060.11	309.060.12		6	43	70	10x20
309.064.11	309.064.12	1/4	6.35	43	70	10x20
309.070.11	309.070.12		7	43	70	10x20
309.075.11	309.075.12		7.5	43	70	10x20
309.080.11	309.080.12		8	43	70	10x20
309.090.11	309.090.12		9	43	70	10x20
309.095.11	309.095.12	3/8	9.52	43	70	10x20
309.100.11	309.100.12		10	43	70	10x20
309.110.11	309.110.12		11	43	70	10x20
309.120.11	309.120.12		12	43	70	10x20
309.127.11	309.127.12	1/2	12.7	43	70	10x20
309.130.11	309.130.12		13	43	70	10x20
309.140.11	309.140.12		14	43	70	10x20
309.150.11	309.150.12		15	43	70	10x20
309.160.11	309.160.12		16	43	70	10x20

spare parts: 990.003.00 Screw M5x10mm

TECHNICAL DETAILS:

- Super-strength steel
- Spiral portion coated with orange or black P.T.F.E.
- T.C.T. head with precision balanced center point - 2 precision ground T.C.T. cutting edges (Z2) - 4 spiral flutes
- 2 negatively ground spurs (V2) - Parallel shank with driving flat and adjustable screw.

APPLICATION: used on boring machines equipped with adaptors or chucks. Used to drill blind holes in solid wood, wood composites, plastic and laminated materials.

372 CARBIDE TIPPED

Order No. Right-hand	Order No. Left-hand	D_Cutting diameter mm	I_Cutting length mm	L_Overall length mm	S_Shank diam. mm
372.050.11	372.050.12	5	65	105	10x30
372.060.11	372.060.12	6	65	105	10x30
372.080.11	372.080.12	8	65	105	10x30
372.100.11	372.100.12	10	65	105	10x30
372.120.11	372.120.12	12	65	105	10x30

spare parts: 990.003.00 Screw M5x10mm

373 CARBIDE TIPPED

Order No. Right-hand	Order No. Left-hand	D_Cutting diameter mm	I_Cutting length mm	L_Overall length mm	S_Shank diam. mm
373.050.11	373.050.12	5	50	85	10x27
373.060.11	373.060.12	6	50	85	10x27
373.080.11	373.080.12	8	50	85	10x27
373.100.11	373.100.12	10	50	85	10x27
373.120.11	373.120.12	12	50	85	10x27

spare parts: 990.003.00 Screw M5x10mm

TECHNICAL DETAILS:

- Super-strength steel
- Spiral portion coated with orange or black P.T.F.E.
- T.C.T. head with precision balanced center point
- 2 precision ground T.C.T. cutting edges (Z2)
- 4 spiral flutes
- 2 negatively ground spurs (V2)
- Parallel shank with driving flat and adjustable screw.

APPLICATION: used on boring machines equipped with adaptors or chucks. Used to drill blind holes in solid wood, wood composites, plastic and laminated materials.

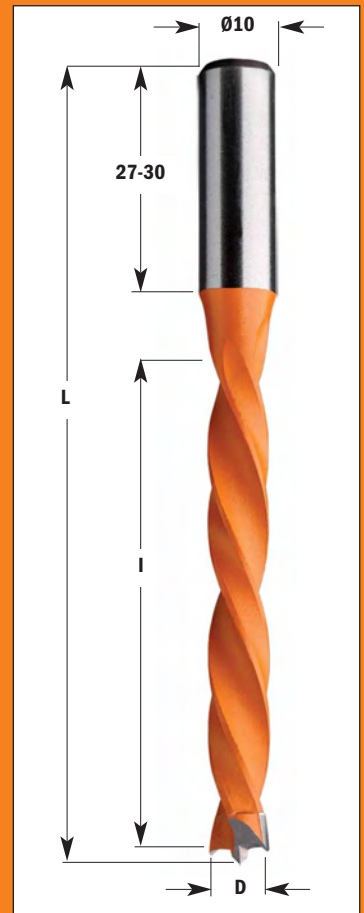

346 CARBIDE TIPPED Shank = M10

Order No. Right-hand	Order No. Left-hand	D_Cutting diameter mm	I_Cutting length mm	LB_Adjusting length mm
346.050.11	346.050.12	5	43	63
346.060.11	346.060.12	6	43	63
346.080.11	346.080.12	8	43	63
346.100.11	346.100.12	10	43	63
346.120.11	346.120.12	12	43	63

FOR USE ON THE FOLLOWING MACHINES:

Ayen, Holzma, Knoevenagel, Mayer, Torwegge

TECHNICAL DETAILS:

- Super-strength steel
- T.C.T. head with precision balanced center point
- 2 precision ground cutting edges (Z2) - 4 spiral flutes
- 2 spurs (V2)

APPLICATION: used on boring machines equipped with chucks. Used to drill blind holes in solid wood, wood composites, plastic and laminated materials.



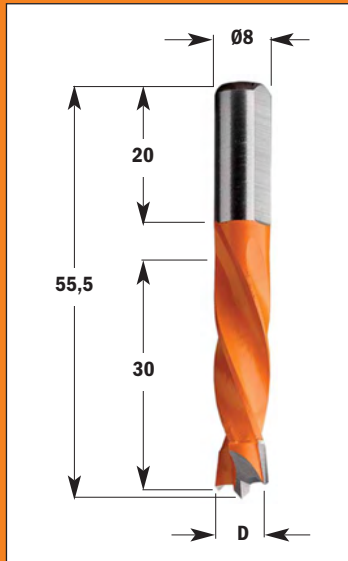

306 CARBIDE TIPPED

Order No. Right-hand	Order No. Left-hand	D_Cutting diameter inches	D_Cutting diameter mm	I_Cutting length mm	L_Overall length mm	S_Shank diam. mm
• 306.030.21			3	18	57.5	8x20
306.050.11	306.050.12		5	30	55.5	8x20
306.055.11	306.055.12	7/32	5.55	30	55.5	8x20
306.060.11	306.060.12		6	30	55.5	8x20
306.064.11	306.064.12	1/4	6.35	30	55.5	8x20
306.070.11	306.070.12		7	30	55.5	8x20
306.080.11	306.080.12		8	30	55.5	8x20
306.090.11	306.090.12		9	30	55.5	8x20
306.100.11	306.100.12		10	30	55.5	8x20
306.120.11	306.120.12		12	30	55.5	8x20

spare parts: 990.003.00 Screw M5x10mm

• Solid Tungsten Carbide

TECHNICAL DETAILS:

- Super-strength steel
- Spiral portion coated with orange or black P.T.F.E.
- T.C.T. head with precision balanced center point - 2 precision ground cutting edges (Z2) - 4 spiral flutes
- 2 negatively ground spurs
- Parallel shank with driving flat and adjustable screw.

APPLICATION: used on boring machines equipped with chucks or adaptors. Used to drill blind holes in solid wood, wood composites, plastic and laminated materials.

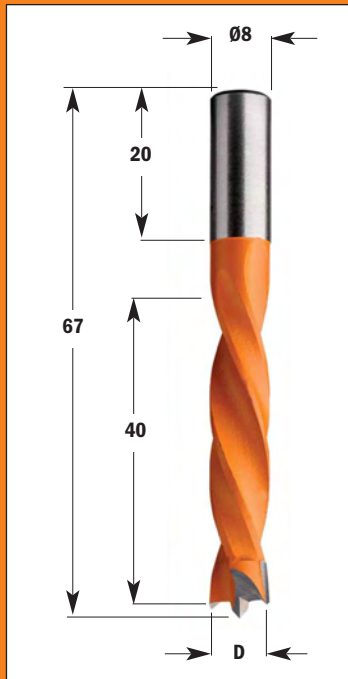

307 CARBIDE TIPPED

Order No. Right-hand	Order No. Left-hand	D_Cutting diameter inches	D_Cutting diameter mm	I_Cutting length mm	L_Overall length mm	S_Shank diam. mm
307.050.11	307.050.12		5	40	67	8x20
307.055.11	307.055.12	7/32	5.55	40	67	8x20
307.060.11	307.060.12		6	40	67	8x20
307.064.11	307.064.12	1/4	6.35	40	67	8x20
307.070.11	307.070.12		7	40	67	8x20
307.080.11	307.080.12		8	40	67	8x20
307.090.11	307.090.12		9	40	67	8x20
307.095.11	307.095.12	3/8	9.52	40	67	8x20
307.100.11	307.100.12		10	40	67	8x20
307.120.11	307.120.12		12	40	67	8x20

spare parts: 990.003.00 Screw M5x10mm

TECHNICAL DETAILS:

- Super-strength steel
- Spiral portion coated with orange or black P.T.F.E.
- T.C.T. head with precision balanced center point - 2 precision ground cutting edges (Z2) - 4 spiral flutes
- 2 negatively ground spurs
- Parallel shank with driving flat and adjustable screw.

APPLICATION: used on boring machines equipped with chucks or adaptors. Used to drill blind holes in solid wood, wood composites, plastic and laminated materials.

364 Shank = Ø10x20mm

Order No.	D _s _For shank diameter mm	L_Overall length mm
364.020.00	2	38
364.025.00	2.5	38
364.030.00	3	38
364.032.00	3.2	38
364.035.00	3.5	38
364.040.00	4	38
364.045.00	4.5	38
364.050.00	5	38
spare parts: 990.001.00	Screw M5x5mm	
991.062.00	Allen key 2.5mm	

To use with the following items: 363

TECHNICAL DETAILS:

- Super-strength steel
- Quick and secure assembly on twist drills
- Precision relief
- Parallel shank with driving flat and length adjusting screw.

APPLICATION:

or use with twist drills with common shank and bushing diameter. Used on boring machines equipped with adaptors chucks.

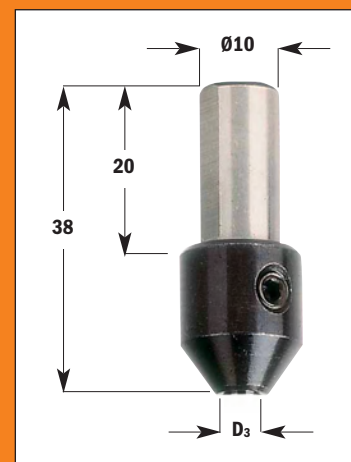

365 Shank = Ø10x23mm

Order No.	D _s _For shank diameter mm
365.020.00	2
365.025.00	2.5
365.030.00	3
365.032.00	3.2
365.035.00	3.5
365.040.00	4
365.045.00	4.5
365.050.00	5

To use with the following items: 363

TECHNICAL DETAILS:

- Super-strength steel
- Shank with driving flat
- Axial cuttings for cylindrical drill clamps

APPLICATION:

used with spiral boring bits with shank diameter equal to the bushing diameter. Used on boring machines equipped with adaptors.

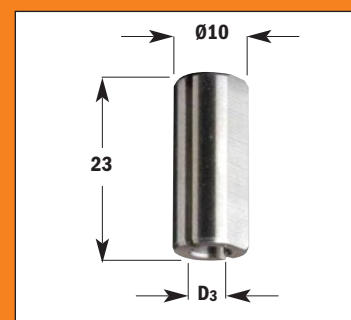

Solid Carbide Twist Drills

363 SOLID CARBIDE

Order No. Right-hand	Order No. Left-hand	D_Cutting diameter mm	I_Cutting length mm	L_Overall length mm	S_Shank diam. mm
"V" point 120° sharpening					
363.020.11	363.020.12	2	25	49	2
363.025.11	363.025.12	2.5	27	57	2.5
363.030.11	363.030.12	3	27	55	3
363.032.11	363.032.12	3.2	27	52	3.2
363.035.11	363.035.12	3.5	27	52	3.5
363.040.11	363.040.12	4	27	55	4
363.045.11	363.045.12	4.5	28	58	4.5
363.050.11	363.050.12	5	28	62	5
X-Treme new down cut round sharpening					
363.025.21	363.025.22	2.5	27	57	2.5
363.030.21	363.030.22	3	27	55	3
363.040.21	363.040.22	4	27	55	4
363.050.21	363.050.22	5	28	62	5

To use with the following items: 364-365

TECHNICAL DETAILS:

- Premium quality S.T.C. - 2 precision ground cutting edges (Z2)
- 2 spiral flutes - Common shank and drilling diameter (S=D)

APPLICATION: used in adapter bushings.

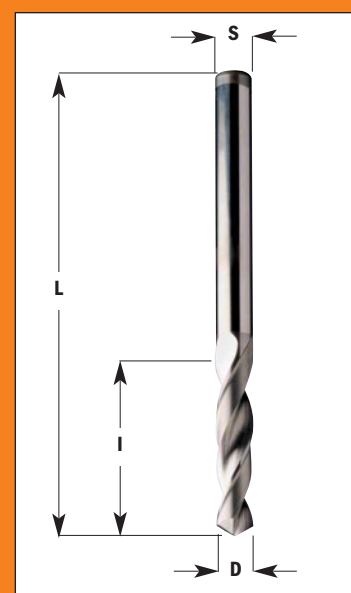

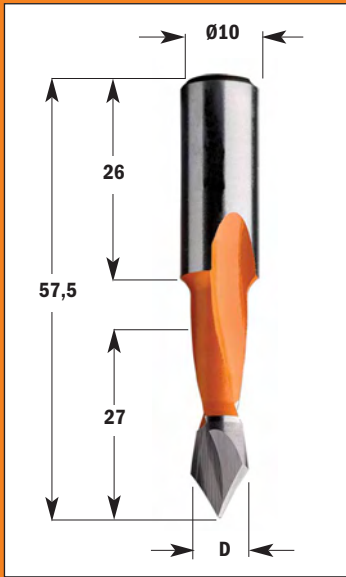

313 CARBIDE TIPPED

Order No. Right-hand	Order No. Left-hand	D_Cutting diameter mm	I_Cutting length mm	L_Overall length mm	S_Shank diam. mm
313.050.11	313.050.12	5	27	57.5	10x26
313.060.11	313.060.12	6	27	57.5	10x26
313.080.11	313.080.12	8	27	57.5	10x26
313.100.11	313.100.12	10	27	57.5	10x26

spare parts: 990.003.00 Screw M5x10mm

For panel with a 20mm maximum thickness

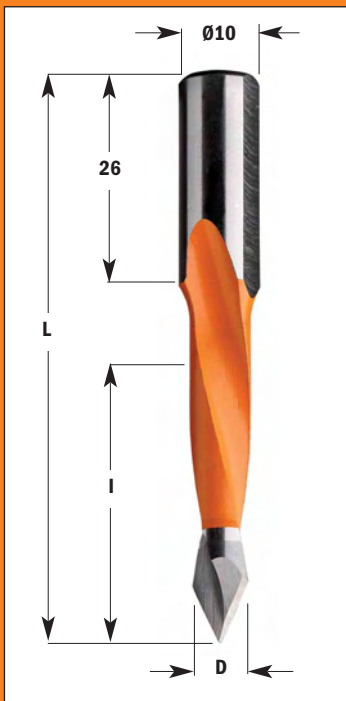

314 CARBIDE TIPPED

Order No. Right-hand	Order No. Left-hand	D_Cutting diameter inches mm	I_Cutting length mm	L_Overall length mm	S_Shank diam. mm
314.040.11	314.040.12	5/32 4	30	70	10x26
314.047.11	314.047.12	3/16 4.76	35	70	10x26
314.050.11	314.050.12	5	35	70	10x26
314.055.11	314.055.12	7/32 5.55	35	70	10x26
314.060.11	314.060.12	6	35	70	10x26
314.064.11	314.064.12	1/4 6.35	35	70	10x26
314.070.11	314.070.12	7	35	70	10x26
314.080.11	314.080.12	8	35	70	10x26
314.090.11	314.090.12	9	35	70	10x26
314.095.11	314.095.12	3/8 9.52	35	70	10x26
314.100.11	314.100.12	10	35	70	10x26
314.120.11	314.120.12	12	35	70	10x26
314.127.11	314.127.12	1/2 12.7	35	70	10x26

spare parts: 990.003.00 Screw M5x10mm

For panel with a 30mm maximum thickness

366 CARBIDE TIPPED

Order No. Right-hand	Order No. Left-hand	D_Cutting diameter mm	I_Cutting length mm	L_Overall length mm	S_Shank diam. mm
366.050.11	366.050.12	5	44	77	10x26
366.060.11	366.060.12	6	44	77	10x26
366.080.11	366.080.12	8	44	77	10x26
366.100.11	366.100.12	10	44	77	10x26
366.120.11	366.120.12	12	44	77	10x26

spare parts: 990.003.00 Screw M5x10mm

For panel with a 40mm maximum thickness

TECHNICAL DETAILS:

- Super-strength steel
- Spiral portion coated with orange or black P.T.F.E.
- T.C.T. head with precision balanced center point - 2 precision ground T.C.T. cutting edges (Z2) - 2 spiral flutes
- Parallel shank with driving flat and adjustable screw.

APPLICATION: used on boring machines and dowel drilling devices. Used for drilling through holes in solid wood, wood composites, plastic and laminated materials.

374 CARBIDE TIPPED

Order No. Right-hand	Order No. Left-hand	D_Cutting diameter mm	I_Cutting length mm	L_Overall length mm	S_Shank diam. mm
374.050.11	374.050.12	5	30	57.5	10x20
374.080.11	374.080.12	8	30	57.5	10x20

spare parts: 990.003.00 Screw M5x10mm

For panel with a 25mm maximum thickness

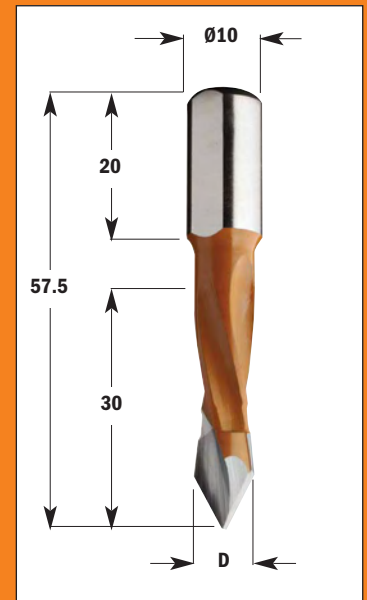

375 CARBIDE TIPPED

Order No. Right-hand	Order No. Left-hand	D_Cutting diameter mm	I_Cutting length mm	L_Overall length mm	S_Shank diam. mm
375.050.11	375.050.12	5	40	70	10x25
375.060.11	375.060.12	6	40	70	10x25
375.070.11	375.070.12	7	40	70	10x25
375.080.11	375.080.12	8	40	70	10x25
375.100.11	375.100.12	10	40	70	10x20

spare parts: 990.003.00 Screw M5x10mm

For panel with a 35mm maximum thickness

TECHNICAL DETAILS:

- Super-strength steel
- Spiral portion coated with orange or black P.T.F.E.
- T.C.T. head with precision balanced center point
- 2 precision ground cutting edges (Z2)
- 4 spiral flutes
- Parallel shank with driving flat and adjustable screw.

APPLICATION: used on boring machines and dowel drilling devices.
Used for drilling through holes in solid wood, wood composites, plastic and laminated materials.

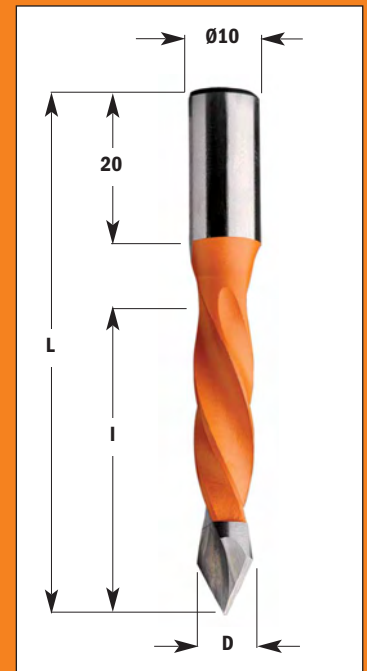

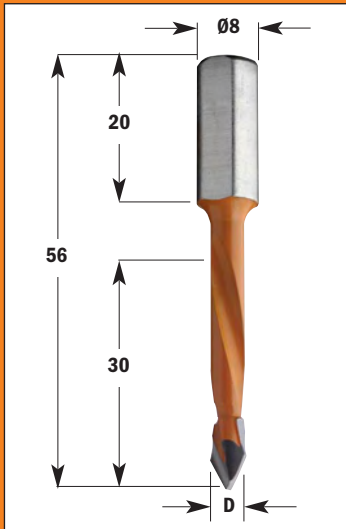

367 CARBIDE TIPPED

Order No. Right-hand	Order No. Left-hand	D_Cutting diameter mm	I_Cutting length mm	L_Overall length mm	S_Shank diam. mm
367.050.11	367.050.12	5	30	56	8x20
367.080.11	367.080.12	8	30	56	8x20

spare parts: 990.003.00 Screw M5x10mm

For panel with a 25mm maximum thickness

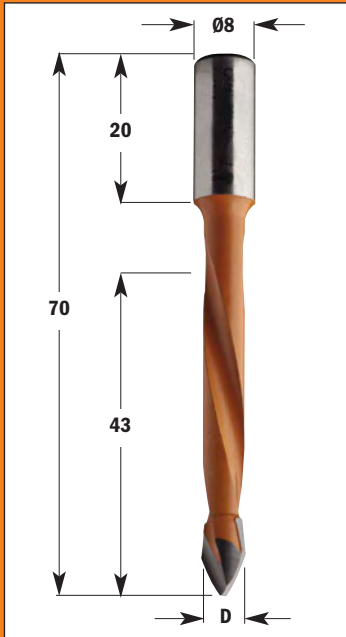

368 CARBIDE TIPPED

Order No. Right-hand	Order No. Left-hand	D_Cutting diameter mm	I_Cutting length mm	L_Overall length mm	S_Shank diam. mm
368.050.11	368.050.12	5	43	70	8x20
368.060.11	368.060.12	6	43	70	8x20
368.070.11	368.070.12	7	43	70	8x20
368.080.11	368.080.12	8	43	70	8x20

spare parts: 990.003.00 Screw M5x10mm

For panel with a 40mm maximum thickness

TECHNICAL DETAILS:

- Super-strength steel
- Spiral portion coated with orange or black P.T.F.E.
- T.C.T. head with precision balanced center point
- 2 precision ground cutting edges (Z2)
- 2 spiral flutes
- Parallel shank with driving flat and adjustable screw.

APPLICATION: used on boring machines and dowel drilling devices.

Used for drilling through holes in solid wood, wood composites, plastic and laminated materials.

316 CARBIDE TIPPED

Order No. Right-hand	Order No. Left-hand	For bit diameter mm	D_Cutting diameter mm
316.040.11	316.040.12	4	16
316.050.11	316.050.12	5	16
316.060.11	316.060.12	6	16
316.070.11	316.070.12	7	16
316.080.11	316.080.12	8	18
316.090.11	316.090.12	9	18
316.100.11	316.100.12	10	20
316.120.11	316.120.12	12	20

spare parts: 990.002.00 Screw M5x5mm
991.062.00 Allen key 2.5mm

For assembly on the spiral head of the bit. Adjustable depth.

For use with the following parts: 306-307-308-309-344-346-372-373-374-375 carbide tipped

TECHNICAL DETAILS:

- Super-strength steel
- 2 precision ground carbide tipped cutting edges (Z2)

APPLICATION: used for chamfering and drilling in solid wood, wood composites, plastic and laminated materials.

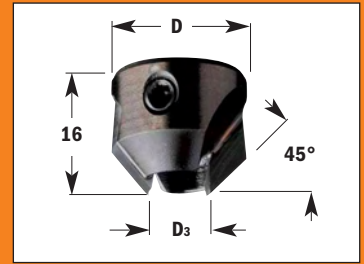

Countersink for 2 Flute Drills

315 CARBIDE TIPPED

Order No. Right-hand	Order No. Left-hand	For bit diameter mm	D_Cutting diameter mm
315.200.11	315.200.12	From 5 to 10	20
315.220.11	315.220.12	From 11 to 12	22

spare parts: 990.006.00 Screw M5x5mm
991.062.00 Allen key 2,5mm

For assembly on the shank of the drill.

For use with the following parts: 310-311-362-313-314-366 carbide tipped

TECHNICAL DETAILS:

- Super-strength steel
- 2 precision ground carbide tipped cutting edges (Z2)
- Clamps directly on to the shank of the drills.

APPLICATION: used for chamfering and drilling in solid wood, wood composites, plastic and laminated materials.

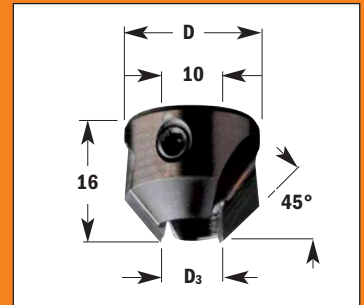

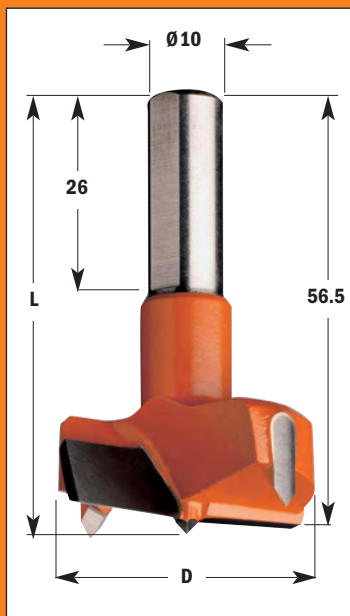

TECHNICAL DETAILS:

- Super-strength steel
- Cutter portion coated with orange or black P.T.F.E.
- T.C.T. head with precision balanced center point
- 2 precision ground cutting edges (Z2)
- 2 negatively ground spurs
- Parallel shank with driving flat and adjustable screw.

APPLICATION: ideal for hinges. Used on boring machines equipped with chucks or adaptors. Used for drilling accurate and clean-cut blind holes in solid wood, wood composites, plastic and laminated materials.



317 CARBIDE TIPPED

Order No. Right-hand	Order No. Left-hand	D_Cutting diameter mm	L_Overall length mm	S_Shank diam. mm
317.140.11	317.140.12	14	57.5	10x26
317.150.11	317.150.12	15	57.5	10x26
317.160.11	317.160.12	16	57.5	10x26
317.170.11	317.170.12	17	57.5	10x26
317.180.11	317.180.12	18	57.5	10x26
317.190.11	317.190.12	19	57.5	10x26
317.200.11	317.200.12	20	57.5	10x26
317.220.11	317.220.12	22	57.5	10x26
317.240.11	317.240.12	24	57.5	10x26
317.250.11	317.250.12	25	57.5	10x26
317.260.11	317.260.12	26	57.5	10x26
317.280.11	317.280.12	28	57.5	10x26
317.300.11	317.300.12	30	57.5	10x26
317.320.11	317.320.12	32	57.5	10x26
317.350.11	317.350.12	35	57.5	10x26
317.380.11	317.380.12	38	57.5	10x26
317.400.11	317.400.12	40	57.5	10x26

spare parts: 990.003.00 Screw M5x10mm

369 CARBIDE TIPPED

Order No. Right-hand	Order No. Left-hand	D_Cutting diameter mm	L_Overall length mm	S_Shank diam. mm
369.140.11	369.140.12	14	70	10x26
369.150.11	369.150.12	15	70	10x26
369.160.11	369.160.12	16	70	10x26
369.180.11	369.180.12	18	70	10x26
369.200.11	369.200.12	20	70	10x26
369.220.11	369.220.12	22	70	10x26
369.250.11	369.250.12	25	70	10x26
369.260.11	369.260.12	26	70	10x26
369.300.11	369.300.12	30	70	10x26
369.350.11	369.350.12	35	70	10x26
369.400.11	369.400.12	40	70	10x26

spare parts: 990.003.00 Screw M5x10mm

Diamond Hinge Boring Bits



new

317 DIAMOND

Order No. Right-hand	Order No. Left-hand	D_Cutting diameter mm	L_Overall length mm	S_Shank diam. mm
317.150.61	317.150.62	15	57.5	10x26
317.350.61	317.350.62	35	57.5	10x26

369 DIAMOND

Order No. Right-hand	Order No. Left-hand	D_Cutting diameter mm	L_Overall length mm	S_Shank diam. mm
369.150.61	369.150.62	15	70	10x26
369.350.61	369.350.62	35	70	10x26

TECHNICAL DETAILS: - Super-strength steel - DP (Polycrystalline Diamond) head with precision balanced center point
 - 2 precision ground DP (Polycrystalline Diamond) cutting edges (Z2)
 - 2 negatively ground DP (Polycrystalline Diamond) spurs (V2) - Parallel shank with driving flat and adjustable screw.

APPLICATION: ideal for hinges. Use on boring machines equipped with adaptors or chucks. Use for drilling accurate and clean-cut blind holes in wood composites, plastic and laminated materials. Long lasting boring performance 20 times comparing to HW material.

301 Shank = M8

Order No. Right-hand	Order No. Left-hand	D ₃ _For shank diameter mm	D ₂ _Overall diameter mm
301.000.01	301.000.02	10	19.5
<i>spare parts:</i> 990.006.00 Screw M5x5mm			
991.062.00 Allen key 2.5mm			

FOR USE ON THE FOLLOWING MACHINES:

Nottmeyer

302 Shank = M10

Order No. Right-hand	Order No. Left-hand	D ₃ _For shank diameter mm	D ₂ _Overall diameter mm
302.080.01	302.080.02	8	16
302.000.01	302.000.02	10	19.5
<i>spare parts:</i> 990.006.00 Screw M5x5mm			
991.062.00 Allen key 2.5mm			

FOR USE ON THE FOLLOWING MACHINES:

Ayen, Holzma, Knoevenagel, Mayer, Torwegge

303 Shank = M10 with centering cone 30°

Order No. Right-hand	Order No. Left-hand	D ₃ _For shank diameter mm	D ₂ _Overall diameter mm
303.080.01	303.080.02	8	16
303.000.01	303.000.02	10	19.5
<i>spare parts:</i> 990.006.00 Screw M5x5mm			
991.062.00 Allen key 2.5mm			

FOR USE ON THE FOLLOWING MACHINES:

Alberti, Balestrini, Bilek, Busellato, Schleicher

304 Shank = M8 with centering cone 20° 48'

Order No. Right-hand	Order No. Left-hand	D ₃ _For shank diameter mm	D ₂ _Overall diameter mm
304.000.01	304.000.02	10	19.5
<i>spare parts:</i> 990.006.00 Screw M5x5mm			
991.062.00 Allen key 2.5mm			

FOR USE ON THE FOLLOWING MACHINES:

Balestrini, Bilek

TECHNICAL DETAILS:

- High precision - Total reliability - Perfectly centered - Rotation defect-free
- Super-strength steel - Precision relief on all surfaces - Quick drill change
- Adaptable to a variety of different spindle nose designs.

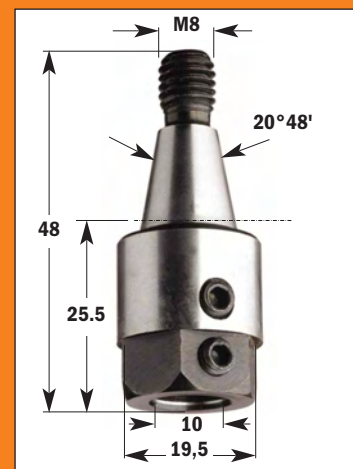
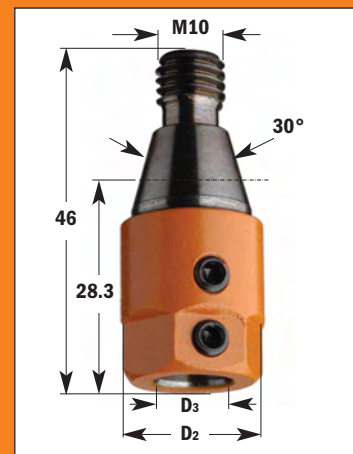
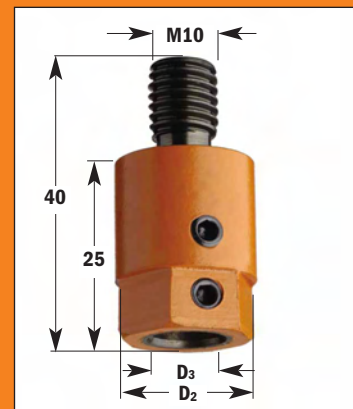
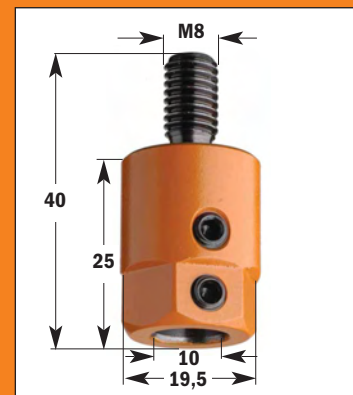

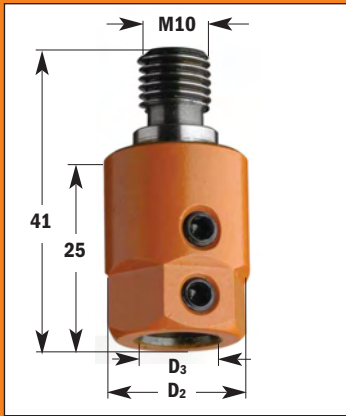

305 Shank = M10 with seating Ø11x4mm

Order No. Right-hand	Order No. Left-hand	D ₃ _For shank diameter mm	D ₂ _Overall diameter mm
305.080.01	305.080.02	8	16
305.000.01	305.000.02	10	19.5

spare parts: 990.006.00 Screw M5x5mm
991.062.00 Allen key 2.5mm

FOR USE ON THE FOLLOWING MACHINES:

Biesse, Masterwood, Morbidelli, Torwegge, Vitap, Weeke

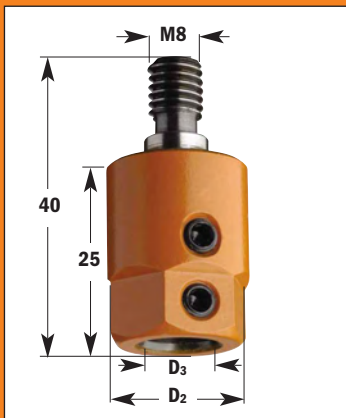

358 Shank = M8 with seating Ø9x4mm

Order No. Right-hand	Order No. Left-hand	D ₃ _For shank diameter mm	D ₂ _Overall diameter mm
358.080.01	358.080.02	8	16
358.000.01	358.000.02	10	19.5

spare parts: 990.006.00 Screw M5x5mm
991.062.00 Allen key 2.5mm

FOR USE ON THE FOLLOWING MACHINES:

Masterwood, Nottmeyer, Morbidelli



360.001 ...for Biesse machines

Order No. Right-hand	Order No. Left-hand	D ₃ _For shank diameter mm	D ₂ _Overall diameter mm
360.001.01	360.001.02	10	20

spare parts: 990.007.00 Screw M6x6mm
991.067.00 Allen key 3mm

FOR USE ON THE FOLLOWING MACHINES:

For Biesse machines with quick drill change attachment

360.101 ...for Vitap machines

Order No. Right-hand & Left-Hand	D ₃ _For shank diameter mm	D ₂ _Overall diameter mm
360.101.00	10	18
spare parts:		
990.015.00	Screw M5x4mm	
991.062.00	Allen key 2.5mm	

FOR USE ON THE FOLLOWING MACHINES:

For Vitap (APA70)

TECHNICAL DETAILS:

- High precision - Total reliability - Perfectly centered - Rotation defect-free - Super-strength steel
- Precision relief on all surfaces - Quick drill change - Adaptable to a variety of different spindle nose designs.



360.201 ...for Morbidelli machines

NEW

Order No. Right-hand & Left-Hand	D ₃ _For shank diameter mm	D ₂ _Overall diameter mm
360.201.00	10	19,25
spare parts:		
990.015.00	Screw M5x4mm	
991.062.00	Allen key 2.5mm	



360.301 ...for Masterwood machines

NEW

Order No. Right-hand & Left-Hand	D ₃ _For shank diameter mm	D ₂ _Overall diameter mm
360.301.00	10	19,4
spare parts:		
990.015.00	Screw M5x4mm	
991.062.00	Allen key 2.5mm	



TECHNICAL DETAILS:

- High precision - total reliability
- Perfectly centred
- Rotation defect-free
- Super-strength steel
- Precision relief on all surfaces
- Quick drill change
- Adaptable to a variety of different spindle nose designs

Conversion Table



Inch Decimals	Inch Fractions (x)						Millimeters					
	1/64	1/32	1/16	1/8	1/4	1/2	mm	1" + (x)	2" + (x)	3" + (x)	4" + (x)	5" + (x)
0.015625	1/64						0.397	25.400	50.800	76.200	101.600	127.000
0.031250		1/32					0.794	25.797	51.197	76.597	101.997	127.397
0.046875	3/64						1.191	26.591	51.991	77.391	102.791	128.191
0.062500			1/16				1.588	26.988	52.388	77.788	103.188	128.588
0.078125	5/64						1.984	27.384	52.784	78.184	103.584	128.984
0.093750		3/32					2.381	27.781	53.181	78.581	103.981	129.381
0.109375	7/64						2.778	28.178	53.578	78.978	104.378	129.778
0.125000				1/8			3.175	28.575	53.975	79.375	104.775	130.175
0.140625	9/64						3.572	28.972	54.372	79.772	105.172	130.572
0.156250		5/32					3.969	29.369	54.769	80.169	105.569	130.969
0.171875	11/64						4.366	29.766	55.166	80.568	105.966	131.366
0.187500			3/16				4.762	30.162	55.562	80.962	106.362	131.762
0.203125	13/64						5.159	30.559	55.959	81.359	106.759	132.159
0.218750		7/32					5.556	30.956	56.356	81.756	107.156	132.556
0.234375	15/64						5.953	31.353	56.753	82.153	107.553	132.953
0.250000					1/4		6.350	31.750	57.150	82.550	107.950	133.350
0.265625	17/64						6.747	32.147	57.547	82.947	108.347	133.747
0.281250		9/32					7.144	32.544	57.944	83.344	108.744	134.144
0.296875	19/64						7.541	32.941	58.341	83.741	109.141	134.541
0.312500			5/16				7.938	33.338	58.738	84.138	109.538	134.938
0.328125	21/64						8.334	33.734	59.134	84.534	109.934	135.334
0.343750		11/32					8.731	34.131	59.531	84.931	110.331	135.731
0.359375	23/64						9.128	34.528	59.928	85.328	110.728	136.128
0.375000				3/8			9.526	34.925	60.325	85.725	111.125	136.525
0.390625	25/64						9.922	35.322	60.722	86.122	111.522	136.922
0.406250		13/32					10.319	35.719	61.119	86.519	111.919	137.319
0.421875	27/64						10.716	36.116	61.516	86.916	112.316	137.716
0.437500			7/16				11.112	36.512	61.912	87.312	112.712	138.112
0.453125	29/64						11.509	36.909	62.309	87.709	113.109	138.509
0.468750		15/32					11.906	37.306	62.706	88.106	113.506	138.906
0.484375	31/64						12.303	37.703	63.103	88.503	113.903	139.303
0.500000					1/2		12.700	38.100	63.500	88.900	114.300	139.700
0.515625	33/64						13.097	38.497	63.897	89.297	114.697	140.097
0.531250		17/32					13.494	38.894	64.294	89.694	115.094	140.494
0.546875	35/64						13.891	39.291	64.691	90.091	115.491	140.891
0.562500			9/16				14.288	39.688	65.088	90.488	115.888	141.288
0.578125	37/64						14.684	40.084	65.484	90.884	116.284	141.684
0.593750		19/32					15.081	40.481	65.881	91.281	116.681	142.081
0.609375	39/64						15.478	40.878	66.278	91.678	117.078	142.478
0.625000				5/8			15.875	41.275	66.675	92.075	117.475	142.875
0.640625	41/64						16.272	41.672	67.072	92.472	117.872	143.272
0.656250		21/32					16.669	42.069	67.469	92.869	118.269	143.669
0.671875	43/64						17.066	42.466	67.866	93.266	118.666	144.066
0.687500			11/16				17.462	42.862	68.262	93.662	119.062	144.462
0.703125	45/64						17.859	43.259	68.659	94.059	119.459	144.859
0.718750		23/32					18.256	43.656	69.056	94.456	119.856	145.256
0.734375	47/64						18.653	44.053	69.453	94.855	120.253	145.653
0.750000					3/4		19.050	44.450	69.850	95.250	120.650	146.050
0.765625	49/64						19.447	44.847	70.247	95.647	121.047	146.447
0.781250		25/32					19.844	45.244	70.644	96.044	121.444	146.844
0.796875	51/64						20.241	45.641	71.041	96.441	121.841	147.241
0.812500			13/16				20.638	46.038	71.438	96.838	122.238	147.638
0.828125	53/64						21.034	46.434	71.834	97.234	122.634	148.034
0.843750		27/32					21.431	46.831	72.231	97.631	123.031	148.431
0.859375	55/64						21.828	47.228	72.628	98.028	123.428	148.828
0.875000				7/8			22.225	47.625	73.025	98.425	123.825	149.225
0.890625	57/64						22.622	48.022	73.422	98.822	124.222	149.622
0.906250		29/32					23.019	48.419	73.819	99.219	124.619	150.019
0.921875	59/64						23.416	48.816	74.216	99.616	125.016	150.416
0.937500			15/16				23.812	49.212	74.612	100.012	125.412	150.812
0.953125	61/64						24.209	49.609	75.009	101.409	126.809	152.209
0.968750		31/32					24.606	50.000	75.406	100.806	126.206	151.606
0.984375	63/64						25.003	50.403	75.803	101.203	126.603	152.003



Boring Bits



Adjustable Countersink 202



Plug Cutters 202



Mortise Chisel & Bit Sets 203



Hinge Boring Bits 203



Forstner Bits 204



Forstner Bit Sets 205

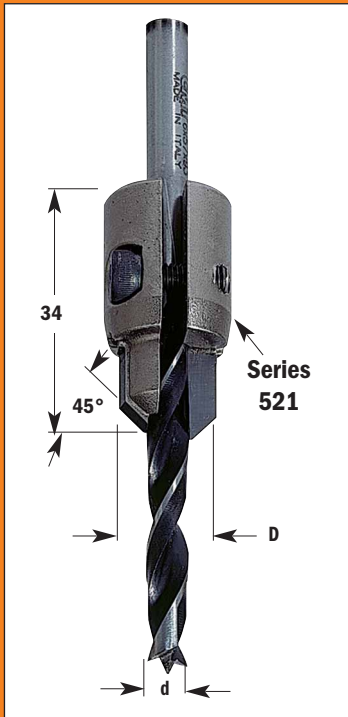

521.001 HW

Order No. Right-hand	D_Cutting diameter inches	d_Small diameter inches
521.001.11	from 7/16 to 19/32	from 3/32 to 9/32

Supplied with hex key

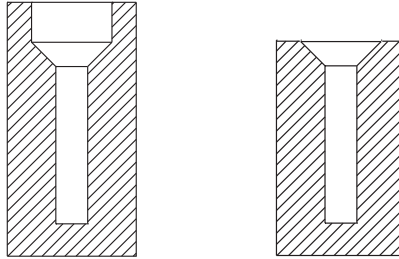

TECHNICAL DETAILS:

- Premium quality T.C.T.
- 2 precision ground T.C.T. cutting edges (Z2)
- Quick and easy change.

APPLICATION: used with spiral bits with parallel shanks.

Twist drills not included.

Plug Cutters



529 SP

Order No. Right-hand	d_Small diameter inches	S_Shank diameter inches	L_Overall length inches	Z_Number of teeth
529.095.31	3/8	1/2	5-1/2	4
529.127.31	1/2	1/2	5-1/2	4
529.158.31	5/8	1/2	5-1/2	4
529.191.31	3/4	1/2	5-1/2	4
529.222.31	7/8	1/2	5-1/2	4
529.254.31	1	1/2	5-1/2	5
529.317.31	1-1/4	1/2	6-5/16	5
529.349.31	1-3/8	5/8	6-5/16	6
<small>new</small> 529.381.31	1-1/2	5/8	6-5/16	6
529.413.31	1-5/8	5/8	6-5/16	6
529.445.31	1-3/4	5/8	6-5/16	6
529.508.31	2	5/8	6-5/16	6

TECHNICAL DETAILS:

- SP steel
- Long lasting cutter performance.

APPLICATION: used to make plugs in hard and soft woods.

543 HS

Order No. Right-hand	D_Cutting diameter inches	S_Shank diameter inches
543.064.51	1/4	3/4
543.079.51	5/16	3/4
543.095.51	3/8	3/4
543.127.51	1/2	3/4
543.158.51	5/8	3/4
543.190.51	3/4	3/4

It's tough to beat the "old faithful" mortise and tenon joint for strength and accuracy, even with all the other joining options in the world of woodworking. It isn't the easiest joint to make, but it sure helps to have the best quality tools in your shop. That's why we've added a new selection of Chisel and Bit sets in all the popular sizes, from 1/4" to 3/4" diameter.

These sets are for use in any standard drill press mortising attachment of mortising machine.



Hinge Boring Bits

391 CARBIDE TIPPED

Order No. Right-hand	D_Cutting diameter mm	L_Overall length mm	S_Shank diameter inches
391.351.11	35	66	1/2
391.352.11	35	66	3/8

TECHNICAL DETAILS:

- Super-strength steel
- Cutter portion coated with black P.T.F.E.
- T.C.T. head with precision balanced center point
- 2 precision ground T.C.T. cutting edges (Z2)
- Parallel shank.

APPLICATION: used for drilling blind holes in solid wood, wood composites, plastic and laminated materials. Ideal for hinges.





537 SP

Order No. Right-hand	D_Cutting diameter inches	L_Overall length inches	S_Shank diameter inches
537.064.31	1/4	3-35/64	3/8
537.095.31	3/8	3-35/64	3/8
537.127.31	1/2	3-35/64	3/8
537.158.31	5/8	3-35/64	3/8
537.190.31	3/4	3-35/64	3/8
537.222.31	7/8	3-35/64	3/8
537.254.31	1	3-35/64	3/8
537.285.31	1-1/8	3-35/64	3/8
537.317.31	1-1/4	3-35/64	3/8
537.349.31	1-3/8	3-35/64	3/8
537.381.31	1-1/2	3-35/64	3/8
537.413.31	1-5/8	3-35/64	3/8
537.445.31	1-3/4	3-35/64	3/8
537.476.31	1-7/8	3-35/64	3/8
537.508.31	2	3-35/64	3/8
537.540.31	2-1/8	3-35/64	3/8

Order No. Right-hand	D_Cutting diameter mm	L_Overall length mm	S_Shank diam. mm
537.100.31	10	90	8
537.120.31	12	90	8
537.140.31	14	90	8
537.150.31	15	90	8
537.160.31	16	90	8
537.180.31	18	90	8
537.200.31	20	90	8
537.220.31	22	90	8
537.240.31	24	90	8
537.250.31	25	90	8
537.260.31	26	90	8
537.280.31	28	90	8
537.300.31	30	90	8
537.320.31	32	90	10
537.350.31	35	90	10
537.380.31	38	90	10
537.400.31	40	90	10
537.450.31	45	90	10
537.500.31	50	90	10
537.550.31	55	90	10
537.680.31	68	159	12.5

new

TECHNICAL DETAILS:

- Super-strength steel SP steel
- Precision balanced center point - 2 spurs (V2)
- 2 precision ground cutting edges (Z2)
- Long lasting cutter performance.

APPLICATION: used to drill precise flat bottom holes with no chipping in any thickness of soft wood. For drilling holes in any direction and making arched openings. For drilling partially overlapped flat bottom holes for easy mortising. For drilling niches used to fix supports.

We offer a wide range of Forstner Bits in the most popular diameters, including hard to find metric sizes. These bits are available individually or in sturdy reusable carrying case sets. You get high performance stagger tooth design on all larger diameter bits (over 1" or 25mm) for clean sharp holes with straight sides and flat bottoms. These bits are ideal for drill presses, electric and cordless drills.



537.000.07



537.000.16

Set contains	Description
Order No. 537.000.07 7 piece Forstner bits set 7-piece Forstner bits set with case Shank 3/8"	Ø1/4" - 3/8" - 1/2" - 5/8" - 3/4" - 7/8" - 1"
Order No. 537.000.16 16 piece Forstner bits set 16-piece Forstner bits set with case Shank 3/8"	Ø1/4" - 3/8" - 1/2" - 5/8" - 3/4" - 7/8" - 1" - 1-1/8" 1-1/4" - 1-3/8" - 1-1/2" - 1-5/8" - 1-3/4" - 1-7/8" - 2" - 2-1/8"
Order No. 537.000.05 5 piece Forstner bits set 5-piece Forstner bits set with case Shank 8-10mm	Ø15 - 20 - 25 - 30 - 35mm
Order No. 537.000.12 12 piece Forstner bits set 12-piece Forstner bits set with case Shank 8-10mm	Ø10 - 12 - 14 - 15 - 16 - 18 - 20 - 22 - 25 - 26 - 30 - 35mm

DESCRIPTION	PAGE
12 piece Router Bit Set	63
13 piece Dovetail & Straight Router Bit Set	67
13 piece Router Bit Set	64
15 piece Router Bit Set	62
2 Flute Dowel Drills	186-187
2 Flute Dowel Drills for Through Holes	192, 194
2 Flute Dowel Drills with Countersink	187
2 Pieces adjustable rounding & chamfering set	111
3 Piece adjustable grooving set	109
3 piece Glass Panel Set	79
3 Piece Junior Raised Panel Sets with Backcutter	73
3 piece Kitchen Sets	77
3 piece Lonnie Bird's Divided Light Door Set	80
3 piece Lonnie Bird's Small Arch Door Set	81
3 Piece Raise Panel Sets with Backcutter	72
3 piece Tongue & Groove Cabinetmaking Set	70
3D Router Carver™ System	96~98
3in1 Flush trim bit for laminates	22
4 Flute Dowel Drills	188~189
4 Flute Dowel Drills for Through Holes	193
40° ATB Fine Cut Off Blades for 2-sided melamine	161
45° Chamfer cutter head	110
45° Lock Miter Bits	52
45° Lock miter cutter head	117
5 piece Chamfer Bit Set	32
5 piece Complete Kitchen Sets	76
5 piece Solid Carbide Spiral Bit Sets	6
6 piece Cabinetmaking Sets	71
6 piece Router Bit Set	65
60° Laser Point bit	28
60° Lettering Bits	29
7 piece Lonnie Bird's Crown Molding Set	82
8 piece Dovetail & Straight Router Bit Set	66
90° V-Groove Bits	28

A	
Adaptors	197~199
Adaptors & Bushings for Twist Drills	191
Additional Templates, Bits and Accessories	91
Adjustable Countersink	201
Adjustable Scoring Blades	164

B	
Balance Blade & Sanding Disk & Saw Blade Stabilizer	166
Beading Bits	37
Biscuit Joiner Blades	165
Bit Organizers	86
Blank Knives	138
Blum, Salice & Häfele Hinges Boring System	88
Bore Reducers	123
Bowl & Tray Bits	29
Building Arched Raised Panel Doors	74-75
Bull Nose Bits	37

C	
Cabinet & Joinery Set	122
Cabinetshop Blades	157-158
Cavetto Bit	34
Chamfer Bits	32
Chestmate™ Router Bits Set	19
Circular Saw Blades	144
Classical Bits	45
Classical Ogee Bits	39-40
Classical Panel Ogee Bits	43
CMT Grand Rabbet Set	31
CMT-Enlock Joining System	87
Collet Chuck HSK	169
Collet Chuck ISO 30	170-171
Collet Chuck MK2/MK3	172
Collet Chuck Parallel Shank Ø25mm	172

DESCRIPTION	PAGE
Combination Blades	156
Combination Trimmer Bits	24
Complete set for MDF Door	178-179
Compound Miter & Radial Blades	155
Compound Miter Blades	155
Conical Scoring Blades	164
Conversion Table	200
Corner Beading Bits	38
Countersink for 2 Flute Drills	195
Countersink for 4 Flute Drills	195
Cove Bits	35
Cove Bits Sets	35
Crosscut and Finish Blades	161
Cut Off ATB Blades	154
Cut Off Blades	154
Cutter Arbor	168

D	
Dado & Planer Bits	10
Dado Pro Set	150
Decorative Beading Bits	42
Diamond Compression Bits	177
Diamond Flush Trim Bits for laminates	22
Diamond Hinge Boring Bits	196
Diamond Saw Blade for Fiber Cement Products	144
Doormaking Templates	86
Double Flute Chamfer Bits	103
Double Flute Flush Trim Bits	102
Double Flute Rabbeting Bits	104-105
Double Flute Roundover Bits	103
Double Flute Straight Bits	101
Double-Bearing Spiral Flush Trim Bits	21
Dovetail Bits	18
Dovetail Bits for Hoffmann®	19
Drawer Lock Bits	47
Dry Cut Blades	159

E	
Entry & Interior Door Router Bit Set	69
Explanation of symbols and abbreviations	5, 166

F	
Finger Joint Bit	55
Finger Pull Bit	48
Flush & V-Groove Bits	23
Flush Trim Bit Set	20
Flush Trim Bits	20
Flute & Bead Sets	43
Forstner Bit Sets	205
Forstner Bits	204

G	
General Blades	156
Glue Line Ripping Blades	153

H	
Hinge Boring Bits	196, 203
Horizontal Raised Panel Bits	57
HWM Reversible Knives	140-141
HWM Reversible Knives for Portable Planers	142

I	
Industrio™ Routing System	93
ITK Combination Blades	149
ITK Fine Cut-Off Blades	147
ITK Fine Finish Blades	148
ITK Finish Blades	145
ITK Finish Compound Miter Blades	148
ITK Framing/Decking Blades	145
ITK General Purpose Blades	146

DESCRIPTION	PAGE
ITK General Purpose Miter Blades	147
ITK Rip Blades	146
J	
Junior Rail & Stile Sets	60
K	
Keyhole Bit and T-Slot Bits	25
L	
Large Decorative Bits	44
Lock Miter Set	53
Long Straight Bits for Laminates	100
Lonnie Bird's Rail & Stile Set	60
M	
Magnetic Knife Setting Jigs	138
Melamine & Fine Cut Off Blades	157
Mini-Spot Circular Blade for Lamello	165
Molding & Profile Set	122
Molding Bits	38
Molding System	46
Mortise Chisel & Bit Sets	203
Mortising Bits	9
Multiprofile Bits	46
Multi-Purpose Rabbeting Bits	30
Multiradius roundover cutter head	112-113
N	
Non-Ferrous Metal, PVC & Melamine Blades	158
O	
Ogee Bits	41
Ogee with Fillet Bits	40
One piece Rail & Stile Bit	59
One piece rail & stile cutter head	119, 121
Orange PTFE Saw Blades	152
Ovolo Bits	34
P	
Panel Door Construction	78
Panel Pilot Bits with guide	27
Panel Sizing Saw Blades	162-163
Parts & Accessories	84-85
Patented Saw Blade Carry Case	166
Pattern Bits	11, 102
Planer & Joint Knives	139
Planer and Jinter Knives HS 18%W	138
Plexiglass and Plastic Blades	160
Plug Cutters	201
Plunge Ogee Bits	41-42
Plywood Groove Sets	10
Pocket-Pro™ Joinery System	92
Precision Collet "ER32"	173
Precision Collet "ER40"	173
Precision Dado Sets	151
Professional Finger Joint Bit	55
Professional finger joint cutter head	115
Professional raised panel cutter head	118
Profile Knives for the Insert Shaper System	124~137
Profiles and Counter Profiles Set	120
R	
Rabbeting Bits	30
Rabbeting cutter head	108
Rail & Stile Bits	59
Raised Panel Bits with Back Cutter	58
Reduction Rings for Saw Blades	165
Reverse Glue Joint Bit	47
Reverse glue joint cutter head	116

DESCRIPTION	PAGE
Ripping Blades	153
Roman Ogee Bits	39
Round Nose Bits	26
Round Nose Sets	27
Roundover and cove cutter head	114
Roundover Bits	36
Roundover Sets	36
Router Bits for Domino® Joiner by Festool®	23
Router Inlay Kit	94
Router Inlay Kit Instruction	95
S	
Screw Slot Bit	25
Shaper Safety Precautions	108
Sharp technology with a new twist	6
Single Flute Straight Bits	100
Slot Cutter Set	16-17
Slot Cutter with Arbor and Bearing	14-15
Slot Cutters and Arbors	14-15
Solid Carbide 1-Edge Spiral Bits	174
Solid Carbide 2-Edge Compression Spiral Bits	174
Solid Carbide 2-Edge Spiral Bits	175
Solid Carbide 3-Edge Spiral Bits	176
Solid Carbide Spiral Bits	7
Solid Carbide Twist Drills	191
Solid Surface Bevel Bits	33
Solid Surface Blades	160
Solid Surface Bowl Bits	33
Spare Parts	105
Spare Parts for cutter heads	123
Spoilboard surfacing router cutters	180
Step-by-Step Window Sash Construction	50-51
Straight Bit long series	13
Straight Bit short series	12
Straight Bits with Plunging Knives	101
Straight router cutters with knives	177
Suggestion for safe routine	4
Super Duty Flush Trim Bits	21
T	
Table Edge & Hand Rail Bits	45
Tenon Cutting Router Bit	68
The ABC's of Panel Door Construction	61
Tongue and Groove Set	17
Traditional Bits	44
Trimmer Bits	24
U	
Ultra ITK Blades for Cordless Saws	149
Universal Assembly Support for Chucks	168
Universal Dovetail Jig	90
Universal Hinges Boring System	89
Universal Shaper cutter heads	123
Using your Crown Molding Set	83
V	
Vertical Raised Panel Bits	56
V-Groove - folding - signmaking CNC router cutters	180
V-Tongue and Groove Set	53
W	
Weatherseal Bits	8
Window Sash Set	49
Window Sill Bits	54
X	
X-Treme Boring Bits	182
X-Treme Dowel Drills	185
X-Treme Dowel Drills for Through Holes	183
X-Treme Solid Carbide Dowel Drills	184

ORDER NO.	PAGE	ORDER NO.	PAGE	ORDER NO.	PAGE	ORDER NO.	PAGE	ORDER NO.	PAGE
03.51	166	272	149	652	100	806	20, 22	855.804B/805B	54
03.51.0047A	86	281	158, 163	652B	100	806.001	20	855.901	44
03.51.0049A	86	282	163	653	101, 177	807	22	855.902	44
03.51.0057A	86	283	161	654	101	811	10, 12	856.501	45
03.51.0058A	86	285	161	656	102	811B	11	856.601/701	45
03.51.0106	86	288	164	657	102	812	13	856.801	46
140	177	289	164	659	103	812.032	8	856.802	46
183.000/100	172	299	165	660	104-105	812B	11	856.851	46
183.200	170	299.101/102	166	661	103	813	25	856.852	46
183.201	170	299.111/112	166	663.001.11	180	813.001	8	857	32
183.210	170	301	197	663.101.11	180	814	26-27	858	28
183.211	170	302	197	690	124~138	815	28	859	41
183.220	170	303	197	692	122-123	816	27	860	41
183.221	170	304	197	694.001	109	818	18-19	861	38
183.250	171	305	198	694.002	110	818.501.11	19	863	34
183.251	171	306	190	694.003	112	818B	18	864	34
183.255	171	307	190	694.004	113	821	24	865	42-43
183.260	168	308	188	694.005	111	822	15	866.5	33
183.300	169	309	188	694.007	114	822A/B	15	866.6	33
183.310	169	310	186	694.008	115	823	14	867.5	38
183.360	168	310.21/22	184	694.009	116	823.001	16	890	57
183.400	172	310.41/42	185	694.011	117	823B	14	890.5	58
183-HSK	168	311	187	694.013	118	824	15	890.6	56
183-ISO	168	311.21/22	184	694.014	119	824.121	14	891.5	59
184.000	173	311.41/42	185	694.015	120-121	824.122	14	891.512	60
184.002	173	313	192	694.100	108	827	34	891.517	60
190	7, 174	313.41/42	183	699	123	835	30	891.521	59
190B	21	314	192	790	140~142	835.503.11	31	899	94
191	7, 175	314.21/22	183	791	84, 105	836	32	990	84-85, 105
191.000.02	6	314.41/42	183	792	138	837	35	990.4	84
191B	21	315	195	794	139	837.001.11	35	991	84, 105
192	7, 175	316	195	796	85	837.501.11	35	993.0	172
192.000.02	6	317	196	799	84-85	838	36	998.001.01	95
192B	21	346	189	800.001.00	62	838.001	36	998.001.01-X12	95
195	176	358	198	800.500	66	838.501	36	998.001.03	95
196	176	360.001	198	800.501	66	839	37	998.001.03-X4	95
198	174	360.101	199	800.503	63	840	39	998.001.04	95
201	153	360.201	199	800.504	65	841	39	998.001.05	95
202	153	360.301	199	800.505	64	842	24	CMT300	90
203	153	362	186	800.506	17	843	24	CMT300-T064	91
205	154	363	191	800.509	76	844	40	CMT300-T080	91
206	154	364	191	800.510	76	845	40	CMT300-T127	91
207	155	365	191	800.511	76	846	40	CMT300-T129	91
208	154	366	192	800.512	77	847	40	CMT300-T190	91
210	157	367	194	800.513	77	848	41	CMT333-03	88-89
213-214	156	368	194	800.514	77	848B	42	CMT333-325	89
215-216	156	369	196	800.515	71	849	29	CMT792	138
219	155	372	189	800.516	77	850	25	CMT-Enlock1	87
221	157	373	189	800.517	72	851	29	Formula 2050	95
222	160	374	193	800.518	73	852	10	PNL-001	86
223	160	375	193	800.519	67	853	23	PNL-002	86
225	158	376-377	187	800.520	71	854	37	PNL-003	86
226	149, 159	380	23	800.521	72	855.002	47	PPJ	92
230	150-151	391	203	800.522	73	855.501	47	PPJ-001	92
236	144	521.001	202	800.523	82	855.502	47	PPJ-002	92
240.004	165	529	202	800.524	81	855.503	52	RCS	96~98
240-241	165	537	204	800.525	80	855.504	52	TMP-001	86
250	145-146	537.000.07	205	800.526	70	855.505	53	TMP-002	86
251	145~147	537.000.16	205	800.527	69	855.506	53	TMP-003	86
252	147	541.0	85	800.606	55	855.601	48	TMP-004	86
253	148	541.5	85	800.616	55	855.701	43	TMP-005	86
255	148	543	203	800.626	17	855.801	49	TMP-006	86
256	149	615.004.01	178	800.627	68	855.803	79		
271	149	651	100	801	9	855.804/805	54		

Formation of Contract:

1. All sales are subject exclusively to these terms and conditions.
2. CMT objects to all additional or different terms and conditions proposed by purchaser.
3. Purchaser shall be bound to these terms and conditions upon the earlier of acceptance of the products ordered or ten (10) days after receipt of CMT's order confirmation, invoice, packing slip or other document containing these terms and conditions.
4. Any order made with reference to CMT's price list shall be deemed to incorporate these terms and conditions.

Pricing and Payment:

1. Prices are subject to change without notice. Goods will be billed at prices in effect at the time of shipment unless otherwise specified by CMT.
2. In the event of a price decrease, adjustments, rebates or refunds for stock on hand are not permitted.
3. Prices listed exclude tax. Buyer is responsible for all federal, state and other applicable taxes.
4. Payment terms are net 30 days. Call your CMT representative for special terms on orders that exceed \$3,000.00 net. Payment terms are based on the invoice date, past due accounts will be charged a one and one-half percent (1-1/2%) service charge where permitted by law.
5. Backorders will be shipped at net 30 day terms and will ship prepaid freight if the original order exceeds \$500.00 in the continental United States and \$1,000 in Canada.
6. All orders are subject to credit approval by CMT.
7. List Prices are "suggested" only, distributors may sell for higher or lower prices.
8. Pricing is valid in the continental United States only, prices for other areas may vary.
9. To secure the purchase price of this and all other orders placed by purchaser, purchaser grants to CMT a continuing purchase money security interest in all products sold, including future orders and to their proceeds.
10. Purchaser must never short-pay invoices. If there is a billing discrepancy, please contact CMT immediately.

Minimum Orders:

1. A \$7.50 handling fee will apply to orders of less than \$75.00 net.
2. For items marked "must be purchased in these multiples," CMT will increase the order quantity when necessary to meet the minimum quantity.

Shipping Terms:

CMT will pay the freight on orders over \$500.00 net to accounts in the continental United States and \$1,000 in Canada, except as noted in item "8" below. All orders under \$500.00 net, and all export orders, will be shipped FOB Greensboro, NC. Notwithstanding payment of freight, risk of loss to all goods passes upon tender of delivery to a common carrier.

Please note the following conditions:

1. Shipment must be to one location in order to qualify for prepaid freight.
2. CMT reserves the right to choose the most economical routing on all pre paid orders.
3. Any claims for shortage or damage of goods must be reported within 10 days of receipt of goods.
4. Add-on orders will not be accepted.
5. Parcel post shipments will be insured at buyer's expense. CMT will not be responsible for placing a valuation on shipments unless requested by the buyer.
6. All shipping dates are estimates only; in no event will CMT be liable to buyer for late delivery.
7. Partial deliveries are acceptable.
8. Standard freight policy does not apply to router table shipments. CMT will pay the freight on orders that include three (3) or more router tables.
9. A \$7.50 handling fee will be added to drop ship orders, including those sent freight collect. This charge will not be added to orders already incurring the \$7.50 fee applied to orders for less than \$75.00

Limited Lifetime Warranty:

1. CMT carbide and carbide tipped router bits and saw blades are designed, engineered and manufactured to uncompromising standards for optimum performance and service life. If, for any reason, you are not satisfied with the performance of your CMT tools, and the tools were used only for their recommended application and in accordance with CMT's recommendations, you may return them to CMT for replacement. Warranty excludes dull, misused, damaged or resharpened tools.
2. THE FOREGOING LIMITED WARRANTY IS GIVEN IN LIEU OF ALL OTHER WARRANTIES, EXPRESS OR IMPLIED, INCLUDING THE IMPLIED WARRANTIES OF MERCHANTABILITY AND FITNESS FOR A PARTICULAR PURPOSE. CMT expressly disclaims all other statements or representations of product quality or performance made by sales representatives or in literature or documents given to buyer.
3. The remedy provided in paragraph 1 is buyer's exclusive remedy for all claims and causes of action based upon or arising out of any allegation of product defect. In no event shall CMT's liability to buyer under any theory of liability exceed the purchase price of the product alleged to be defective.

Returned Goods:

CMT will accept the return of goods that are defective or have been shipped in error. All returned goods must be accompanied by a returned goods authorization number, which must be obtained from the CMT office or a CMT authorized agent PRIOR to the return. If a return is authorized, the following conditions apply:

1. Credit will be issued at the price paid or the current price, whichever is lower, less a 15% restocking and reconditioning charge. (Restocking charge does not apply to defective goods).
2. The shipper must pay transportation charges.
3. Any approved return of inventory must be accompanied by an order in an amount at least equal to the net value of the credit. (Does not apply to defective goods)
4. Written authorization must be obtained from CMT before the return will be accepted.

General Conditions:

CMT USA, Inc. reserves the right to make product changes without notice and without obligating itself to make these changes on previously sold products. Title and risk of loss or damage to the goods passes to the buyer upon delivery to the carrier regardless of who pays the shipping cost.

Liability:

CMT shall not be liable for damages to goods, property or persons due to improper installation or misapplication of equipment. IN NO EVENT WILL CMT BE LIABLE FOR LOST PROFITS, LOSS OF GOOD WILL, CONSEQUENTIAL, INCIDENTAL OR PUNITIVE DAMAGES OF ANY KIND, EVEN IF CMT HAS BEEN NOTIFIED OF THE POSSIBILITY OF CONSEQUENTIAL DAMAGES.

Disputes:

Buyer consents to the exclusive jurisdiction of the General Courts of Justice, Superior Court Division of the State of North Carolina for the adjudication of all claims and disputes arising out of or related to the sale of products and waives any objection to venue or convenient forum with respect to said court sitting in Greensboro, North Carolina. This contract and performance under shall be deemed made and performed in the State of North Carolina, and the domestic laws of that State shall govern its interpretation, construction and enforcement.

CMT USA, INC. 7609 BENTLEY ROAD SUITE D, GREENSBORO, NC 27409 PHONE 336-854-0201 FAX 336-854-0903

TM: CMT, the CMT logo and the orange color applied to tool surfaces are trademarks of C.M.T. UTENSILI S.P.A.
© C.M.T. UTENSILI S.P.A.

This document has been sent for your personal use only. All usage and reproduction is forbidden without written permission from C.M.T. UTENSILI S.P.A.



Router Bits



Router Bit Sets



Jig & Accessories



Router Bits w/knives



Cutter heads & knives



Saw Blades



Solid Carbide & Chucks

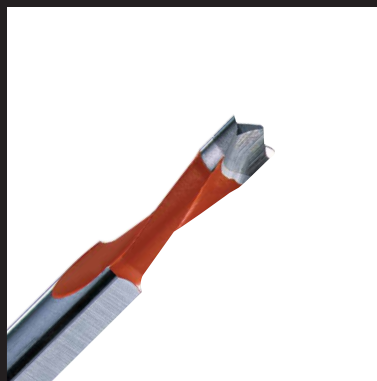

Dowel Drills



Boring Bits

CMT USA, Inc.

7609 Bentley Road Suite D
Greensboro, NC 27409

phone 336.854.0201
toll-free 888.268.2487
fax 336.854.0903
free-fax 800.268.9778

e-mail info@cmtusa.com
web site www.cmtusa.com

